

Visit us on the Internet:

www.embedded-world.de

www.standconfigurator.com

Order form	Deadline/done	Order form	Deadline/done
1 Important information, approvals and order for stand partition walls			
Info 1 Important information about the event		P1 Stand design approval	immediately <input type="checkbox"/>
Info 2 General Terms of Contract for the Exhibitors Info Manual		P2 Approval of deviations from the fire prevention regulations	immediately <input type="checkbox"/>
Info 3 Information from A-Z		P4 Use of stand after exhibition closes – Stand parties	immediately <input type="checkbox"/>
Info 4 Technical regulations 2017		P5 Registration of exhibitor's own WLAN access point on the stand	immediately <input type="checkbox"/>
i4.1 Instruction sheet "Technical data for halls" 2017		S1 Stand design information/order for stand partition walls	immediately <input type="checkbox"/>
i4.2 Instruction sheet "Installation of sprinkler-compatible ceiling fabrics" 2017			
i4.3–i4.12 Further instruction sheets 2017			
Info 6 Your partners of the Exhibition Center Nuremberg			

2 Service order forms

Stand construction and layout

Complete rental stands, basic rental stands, individual stand design, furniture sets, rental furniture, stand fascias and lettering/graphics, digital prints and graphic articles, floral stand decoration, landscaping services

S0 All complete rental stands at a glance	
SV.01 Complete rental stands embedded 1 and 2	14.12.2016 <input type="checkbox"/>
S0.10 Complete rental stand JUNO	14.12.2016 <input type="checkbox"/>
S0.11 Complete rental stand PALLAS	14.12.2016 <input type="checkbox"/>
S0.20 Complete rental stand MARS	14.12.2016 <input type="checkbox"/>
S0.21 Complete rental stand MERCURY	14.12.2016 <input type="checkbox"/>
S0.30 Complete rental stand EARTH	14.12.2016 <input type="checkbox"/>
S0.31 Complete rental stand MOON	14.12.2016 <input type="checkbox"/>
S0.40 Complete rental stand APOLLO	14.12.2016 <input type="checkbox"/>
S0.41 Complete rental stand POLLUX	14.12.2016 <input type="checkbox"/>
S0.50 Complete rental stand HELIOS	14.12.2016 <input type="checkbox"/>
S0.51 Complete rental stand OBERON	14.12.2016 <input type="checkbox"/>
S0.60 Complete rental stand CALYPSO	14.12.2016 <input type="checkbox"/>
S0.61 Complete rental stand KALLISTO	14.12.2016 <input type="checkbox"/>
S0.70 Complete rental stand SIRIUS	14.12.2016 <input type="checkbox"/>
S0.71 Complete rental stand PLUTO	14.12.2016 <input type="checkbox"/>
S0.81 Complete rental stand VESTA	14.12.2016 <input type="checkbox"/>
S0.95 Complete rental stand SATURN	14.12.2016 <input type="checkbox"/>
S0.99 Complete rental stand SUN	14.12.2016 <input type="checkbox"/>
S1.10 Basic rental stand Syma system	14.12.2016 <input type="checkbox"/>
S1.11 Basic rental stand PRIMO	14.12.2016 <input type="checkbox"/>
S1.15 Basic rental stand COONS	14.12.2016 <input type="checkbox"/>
S1.19 Enquiry Architectural stand	14.12.2016 <input type="checkbox"/>
S1.40 Questionnaire for individual stand design	immediately <input type="checkbox"/>
S1.45 Plan of stand	14.12.2016 <input type="checkbox"/>
S1.50–S1.51 Furniture sets	14.12.2016 <input type="checkbox"/>
S1.60–S1.62 Rental of extra stand equipment, floor coverings and furniture (:mesomondo)	14.12.2016 <input type="checkbox"/>
S1.64–S1.66 Rental of extra stand equipment, floor coverings and furniture (Wörnlein)	14.12.2016 <input type="checkbox"/>
S1.67 Furniture rental (Hummel)	14.12.2016 <input type="checkbox"/>
S1.70 Fascias and lettering (:mesomondo)	14.12.2016 <input type="checkbox"/>
S1.71 Fascias and lettering/graphics (Wörnlein)	14.12.2016 <input type="checkbox"/>
S1.75 Digital prints and graphic articles	14.12.2016 <input type="checkbox"/>
S1.80 Floral stand decoration	6.3.2017 <input type="checkbox"/>
S1.82 Floral stand decoration	6.3.2017 <input type="checkbox"/>
S1.85 Landscaping services	13.2.2017 <input type="checkbox"/>

Technical services

Electricity, suspensions, compressed air, water, telecommunications, kitchen appliances, refrigeration/refrigerating, freezing and catering equipment, media and event equipment, lead retrieval system, fire extinguishers

S2.10 Electricity supply, plan	10.1.2017 <input type="checkbox"/>
S2.11 Plan of electricity supply	10.1.2017 <input type="checkbox"/>
S2.15 Approval/order for suspension	10.1.2017 <input type="checkbox"/>
S2.16 Suspension from hall roof – plan of stand	
S2.17 Accessories for suspension + lighting, plan	14.12.2016 <input type="checkbox"/>
S2.20 Compressed air supply	10.1.2017 <input type="checkbox"/>
S2.30–S2.31 Water supply and drainage	14.12.2016 <input type="checkbox"/>
S2.40 Communication – Internet	14.12.2016 <input type="checkbox"/>
S2.41–S2.42 Communication – Phone	14.12.2016 <input type="checkbox"/>
S2.43 Communication – PC-Equipment	14.12.2016 <input type="checkbox"/>
S2.45 Communications – Plan	14.12.2016 <input type="checkbox"/>
S2.46 Communication WLAN professional	14.12.2016 <input type="checkbox"/>
S2.50–S2.51 Kitchen appliances, refrigerated, freezing and catering equipment, plan	14.12.2016 <input type="checkbox"/>
S2.60–S2.61 Media and event equipment	14.12.2016 <input type="checkbox"/>
S2.62 Media and event equipment	14.12.2016 <input type="checkbox"/>
S2.65 Lead retrieval system	immediately <input type="checkbox"/>
S2.70 Fire extinguishers	immediately <input type="checkbox"/>

Logistics and catering

Catering, water coolers, rental crockery, dishwashing service, cleaning of stand, waste disposal, forwarding agent, empty containers storage, hand truck rental, working platforms/working equipment, rental of ladders, guarding of stands, parking permits, travel tickets

S3.10 Catering, stand catering, (Lehrieder)	14.12.2016 <input type="checkbox"/>
S3.16 Water coolers	14.12.2016 <input type="checkbox"/>
S3.18 Rental crockery, dishwashing service	14.12.2016 <input type="checkbox"/>
S3.20 Cleaning of stand	14.12.2016 <input type="checkbox"/>
S3.21 Waste disposal	14.12.2016 <input type="checkbox"/>
S3.30 Forwarding agent, empty containers storage	14.12.2016 <input type="checkbox"/>
S3.31 Hand truck rental	14.12.2016 <input type="checkbox"/>
S3.32 Working platforms/working equipment	14.12.2016 <input type="checkbox"/>
S3.35 Rental of ladders	14.12.2016 <input type="checkbox"/>
S3.40 Guarding of stands	14.12.2016 <input type="checkbox"/>
S3.50 Permanent parking permits for cars, travel tickets	14.12.2016 <input type="checkbox"/>

Marketing and additional services

Advertising, hotel reservation, hostesses/service personnel/helping hands, exhibition events, exhibition staff, insurance

Marketing services

S4.02 Exclusive Marketing

Additional services

S4.19 PartnerHotels of NürnbergMesse	immediately <input type="checkbox"/>
S4.20 Hotel reservation	immediately <input type="checkbox"/>
S4.21 Hotels	immediately <input type="checkbox"/>
S4.30 Hostesses/service personnel/helping hands	immediately <input type="checkbox"/>
S4.31 Exhibition events	immediately <input type="checkbox"/>
S4.40 Hostesses and exhibition staff	immediately <input type="checkbox"/>
S4.70 Insurance	14.12.2016 <input type="checkbox"/>

Miscellaneous

Special Terms of Business for On-Site Advertising

Please make sure you send back the forms in time.
We regret that no responsibility can be accepted for errors or omissions due to late dispatch of order forms. A surcharge is also levied on orders received after the deadline.
Price changes and errors excepted.

Important information for embedded world 2017

The following information and guidelines, the "Special Conditions for Participation in embedded world 2017" and "General Conditions for Participation in Fairs and Exhibitions" included with the application form, and the NürnbergMesse site regulations (hereinafter referred to as General Terms of Business of NürnbergMesse) constitute the contractual basis for participation in embedded world 2017.

Please note Info 3: "Information from A-Z"

1. Assembly

Friday,	10 March 2017	7:00 – 24:00
Saturday,	11 March 2017	7:00 – 24:00
Sunday,	12 March 2017	7:00 – 24:00
Monday,	13 March 2017	7:00 – 20:00

Exhibition stands on which assembly has not been started by 15:00 on Monday, 13 March 2017 will be decorated by the organizer at the exhibitor's cost, if they cannot be otherwise disposed of.

2. Opening times

Tuesday,	14 March 2017	9:00 – 18:00
Wednesday,	15 March 2017	9:00 – 18:00
Thursday,	16 March 2017	9:00 – 17:00

Exhibitors are admitted to embedded world 2017 one hour before the opening time each day. The exhibition stands are to be occupied by not later than 15 minutes before the exhibition opens. For security reasons, exhibitors must leave the halls by not later than 30 minutes after exhibition closing time.

Other exhibition stands are not to be visited outside the daily opening times without the permission of the stand holder.

3. Dismantling

Thursday,	16 March 2017	17:00 – 24:00
Friday,	17 March 2017	7:00 – 19:00

Stands are not to be partly or fully dismantled or exhibits removed before the end of the event. Exhibitors contravening this rule are liable to a penalty amounting to 50 % of the stand rent. The exhibition area is to be restored to its original state after dismantling the stand. The exhibitor is responsible for any damage caused by incorrect handling.

The organizer is entitled to dismantle and store the stand equipment and exhibits at the exhibitor's cost if the stand space is not cleared by the end of the official dismantling time.

Vehicle access to the loading yards is only possible on payment of a **deposit of EUR 100** (exception: trucks of 7.5 tons or more during dismantling). The deposit will be refunded if the vehicle leaves the loading yard within the time limits mentioned on Info 3, Item 45.

3.1 Extension of stand assembly and dismantling times

NürnbergMesse may approve an extension of the stand assembly and dismantling times in the halls in special cases. An appropriate written application must be submitted to the exhibition team in due time in each case.

The exhibitor or stand construction company will be charged a fixed amount of EUR 250/day and per stand for the resulting provision and operating costs.

4. Passes for assembly and dismantling staff

Access to the halls during assembly and dismantling times is only permitted with special passes. Your allocation of free assembly and dismantling passes is based on the size of your stand.

These passes for assembly and dismantling are not valid during the fair.

5. Exhibitor passes

Every exhibitor receives free passes for the necessary stand and operating personnel according to the size of his stand. 3 passes are issued for up to 10 m² stand space plus two passes for each further full 10 m².

Any additional exhibitor passes required can be purchased for entitled persons at a price of EUR 11.90 each including VAT at the statutory rate.

Exhibitor passes are only to be issued to personnel working on the exhibitor's stand.

6. Permanent parking permits

See Info 3 and Form S3.50.

7. Stand layout

The exhibitor is responsible for stand equipment and decoration.

Exhibitors are obliged to decorate their stands carefully and in good taste. Stands which do not conform to the accepted standards will not be approved by the organizer until the necessary changes have been made. Unacceptable advertising will be similarly affected.

The overriding principle for the design of all exhibition stands is transparency. All open sides of the stand must be freely accessible.

This means that at least **50 %** of the respective gangway side must **not** be obstructed by **structures** or fittings.

The minimum height for exhibition stands is 2.50 m.

The stand partition walls of all types of stands directly adjoining the stands of other exhibitors must not exceed a height of 3.50 m **unless permission** has been granted.

The backs of stand partition walls, advertising carriers or other design elements facing neighboring stands and exceeding a height of 2.50 m must be of neutral design and clean and must not contain any text or graphics.

Exhibition stands of 400 m² or more are subject to approval.

This also applies to stands exceeding a height of 3.50 m.

Approval is to be applied for using Form P1 "Stand design approval".

The maximum stand height is 5.80 m.

Stands are to be provided with an adequate floor covering (e.g. carpet, parquet, PVC) by exhibitors. The name and address of the stand holder are to be clearly indicated on the stand for the full duration of the event.

The exhibitor agrees to erect a 2.50 m high own stand partition on all closed sides of the stand space.

If the exhibitor does not use his own stand partition or a rental stand, own stand partition walls are to be ordered from the ServicePartners. Stand partition walls are available for rental in wood or plastic-coated finish or without wallpaper. Walls without wallpaper must be papered and painted. Chipboard panels (height approximately 2.50 m) are permanently fixed to the hall walls by NürnbergMesse. These panels are wallpapered and painted white (note: use special paste for wallpapering over this), but may show signs of use. **They therefore count as partition walls that are not wallpapered and are charged accordingly (see Form S1).** The wallpaper must be stripped by the exhibitor after the event or the walls will be stripped and cleaned at the exhibitor's cost. Wallpapering, painting and stripping can be ordered on Form S1.64.

If a rental exhibition stand is not used, a fascia (0.30 m high) must be fitted on all open sides of the stand space. The fascia can be omitted if the necessary stand quality is assured in some other way.

Stand partition walls, floors, hall walls, pillars, installations, fire-fighting equipment and other permanent hall fixtures must not be pasted over, nailed, painted or damaged in any other way.

The exhibitor is responsible for any damage and will be charged with the cost of repair. Any pillars, installations and fire-fighting equipment located within the stand are part of the allotted stand space and must be accessible at all times.

Floor coverings in the stands are only to be fixed with double-sided adhesive tape (following tapes are to be used: tesafix no. 4964).

If the remains of other adhesive tapes must be removed from the hall floor after the end of dismantling, the cleaning costs will be charged to the exhibitor. The same applies to the remains of carpets etc.

The exhibitor agrees to comply with these conditions. Non-compliance may result in claims for damages by the organizer or the neighboring exhibitors affected.

(continued)

8. WLAN (Wireless Local Area Network)

Exhibitors may only set up a WLAN (Wireless Local Area Network), if this has been expressly approved in writing by the Exhibition Services Department (see Form P5).

A WLAN used without approval can lead to serious technical disturbances. The exhibitor is liable for damage caused by the operation of a WLAN without approval. The Exhibition Services Department will be pleased to advise on the approval and setting up of a WLAN.

Unify Deutschland GmbH & Co. KG is the sole supplier of a WLAN infrastructure for commercial use on the NürnbergMesse site. NürnbergMesse grants Unify Deutschland GmbH & Co. KG exclusive **frequency control over channels 2 to 13 for WLAN in the 2.4 GHz band** for the full-coverage WLAN service on the NürnbergMesse site.

Only **channel 1 in the 2.4 GHz band (2412 MHz)** is available on the NürnbergMesse site for use for all other applications/WLAN networks for both operation by ServicePartners of NürnbergMesse (Unify Deutschland GmbH & Co. KG) and operation of radio/WLAN networks set up by exhibitors themselves.

NürnbergMesse reserves the right to refuse approvals or not to approve applications for exhibitors' own WLAN networks, depending on the number and physical assignment per hall.

As part of quality assurance measures, both unregistered and approved WLAN networks and WLAN networks with excessive transmit power levels will be identified and the operators notified. These networks may possibly be approved after checking or are to be shut down if requested by NürnbergMesse – there is no legal entitlement to approval.

If no amicable solution is possible, technical measures will be implemented to prevent the illegal operation of such WLAN networks.

9. Exhibition priority

An application for exhibition priority has been submitted to the Federal Ministry of Justice. The priority certificate safeguards certain patent rights until application to a patent office in Germany and abroad.

1. The following General Terms of Contract shall apply to the relationship between the exhibitor and NürnbergMesse GmbH (hereinafter referred to as NürnbergMesse) for events at which NürnbergMesse is the organizer.
2. Conflicting contractual terms of the exhibitor are not recognized. Additional agreements shall become effective only after confirmation in writing by NürnbergMesse.
3. The contract is concluded between the exhibitor and NürnbergMesse. The ServicePartner (or subcontractor) stated on the form, who acts as the representative of NürnbergMesse, is the customer's contact for all matters concerning this contract. The forms must be used for all orders. Any illustrations shown are only examples. If necessary, NürnbergMesse is entitled to have the service ordered provided by another ServicePartner. In this case, the customer will be notified of the other ServicePartner in good time.
4. If ServicePartners act as subcontractors for NürnbergMesse, the "Special Conditions of NürnbergMesse" of the ServicePartner shall also apply. The "Special Conditions for Services" shall apply in addition to the General Terms of Contract, which take priority.
5. The validity of the "General Conditions for Participation in Fairs and Exhibitions" and the "Special Conditions for Participation" of NürnbergMesse is not affected by the General Terms of Contract. In case of contradictions to the General Terms of Contract, the "General Conditions for Participation in Fairs and Exhibitions" and the "Special Conditions for Participation" shall take priority.
6. NürnbergMesse is not obliged to check the information provided by the exhibitor for correctness and completeness. Any doubts shall be to the detriment of the exhibitor.
7. If services offered by NürnbergMesse are provided by ServicePartners, accounts are settled directly by the ServicePartner on behalf of and for the account of NürnbergMesse. Collection on the stand during the exhibition is admissible. The following credit cards are accepted: MasterCard, American Express, VISA or Diners Club.
8. Unless otherwise indicated, all prices stated are subject to statutory VAT if the service is taxable in Germany. Payments are due in full immediately on receipt of the invoice. Invoices are made out in EUR.
9. If the exhibitor defaults on payments, interest on arrears shall be payable at a rate of 8 % above the currently applicable base lending rate of the German Federal Bank or at a rate of 8 % above the successor instrument designated by the European Central Bank.
10. If the contractually agreed service provided by the ServicePartner is defective or incomplete, claims shall be asserted exclusively against the ServicePartner.
11. The exhibitor is obliged to check the services provided for defects and completeness without delay. In order to avoid the loss of all claims, the exhibitor shall notify the ServicePartner of any apparent defects or incompleteness in writing immediately after detection.
12. NürnbergMesse shall not be liable for any kind of personal injury or damage to property, unless NürnbergMesse or its subcontractors have caused the damage through intent or gross negligence. This restriction shall not apply in the case of violation of substantial obligations.
13. The place of fulfillment is Nürnberg. German law shall prevail.
14. The place of jurisdiction for all legal proceedings is Nürnberg, if the parties to the contract are businessmen or the exhibitor has no place of general jurisdiction in the Federal Republic of Germany.
15. In case of a provision of these General Terms of Contract being or becoming null and void, the effectiveness of the remaining provisions shall not be affected.
16. Once admission has been confirmed, the exhibitor must pay charges even if he withdraws his application or does not exhibit. The organizer also reserves the right to assert claims for damages. If the exhibitor cancels the order for rental exhibition stands and/or other services, the following cancellation fee is payable based on the value of the order.
 - 90 days to 15 days before start of assembly (see Special Conditions for Participation) of the event 25 % of the order value
 - 14 days to 1 day before start of assembly (see Special Conditions for Participation) of the event 80 % of the order value
 - the full amount is payable from the start of the assembly period.The exhibitor retains the right to prove that the requested compensation for costs incurred is too high.

- 1. Camping site**
 The parking of caravans and mobile homes at the Exhibition Center Nuremberg is prohibited. Please use the camping site only a few minutes drive away. 160 spaces, opening times: all year round. Prices: on request. Facilities: sanitary facilities, bistro, playground, table tennis, tennis court. You should inquire about vacancies a few days before arrival.
 Knaus Camping park Nürnberg
 Hans-Kalb-Straße 56, 90471 Nürnberg
 Tel +49 (0) 9 11. 9 81 27 17, Fax +49 (0) 9 11. 9 81 27 18
 nuernberg@knauscamp.de, www.knauscamp.de
- 2. Cash dispensers**
 Entrance Mitte and NCC Ost.
 Cash obtainable with EC-card or credit card.
- 3. Catering**
 Form S3.10
 Lehrieder Catering-Party-Service GmbH & Co. KG
 Exhibition center restaurants, stand catering, catering arrangements for receptions, conferences and meetings.
- 4. Cleaning**

 - 4.1 General cleaning**
 Cleaning of the site, halls and gangways is arranged by the organizer. The cleaning company commences final cleaning at 20:00 on the last assembly day. Cartons, battens, planks, crates etc. still in the gangways at this time will be regarded as refuse and removed (see Info 4, 6.1 – “Waste Management”).
 - 4.2 Stand cleaning**
 Form S3.20
 Kiefer GmbH (Halls 3–7A)
 dias Gebäudemanagement GmbH (Halls 1, 2, 8–12)
 Stand cleaning which is undertaken by the exhibitor himself must be completed 30 minutes after exhibition closing time.
- 5. Communication/Telecommunications**
 Forms S2.40 – S2.45
- 6. Compressed air supply**
 Form S2.20
 SAG GmbH
- 7. Conference/meeting rooms for press conferences**
 Conference and meeting rooms of all sizes are available for exhibitor press conferences in the Exhibition Center Nuremberg. Please notify us of your requirements, quoting date and number of persons. Please coordinate the dates planned for press conferences with the NürnbergMesse Public and Media Relations department.
 Tel +49 (0) 9 11. 86 06-83 55, Fax +49 (0) 9 11. 86 06-12 83 55
- 8. Customs**
 The customs office on the exhibition site is open for large international exhibitions (ServicePartnerCenter, 1st floor). The opening times are shown in the Last-Minute Information. You can also contact our forwarding agents about customs matters; see Item 21 “Forwarding agent, transport services”).
- 9. Delivery of goods**
 See Item 45 “Traffic and parking regulations”.
- 10. Dispensing equipment**
 Dispensing systems intended for operation at the event must be provided with a risk assessment issued by the manufacturer or renter and this must be shown on request.
- 11. NEW! Electric charging station**
 Three charging pillars with 2 connections each are available on the site of NürnbergMesse GmbH. Information about their location and terms of use is obtainable at www.nuernbergmesse.de/en/e-charging-station. For further information, please contact:
 Harald Knaus – Der Elektroprofi GmbH
 Tel +49 (0) 11. 86 06-88 80
 emobility@nuernbergmesse.de
- 12. Electricity supply**
 Form S2.10
 SAG GmbH
 Connections to the main supply network may only be made by the ServicePartner appointed by the organizer. It is recommended that work within the stand is also carried out by this company.
- 13. NEW! e-mobility** – see item 11 electric charging station
- 14. Empty containers**
 Form S3.30
 The storage of empty containers on the stands, in the halls or in the loading yards is not permitted during assembly, exhibition or dismantling. Containers are to be collected and stored by the respective exhibition forwarding agent.
- 15. Exhibition Services**
 The Exhibition Services Team advises you on all kinds of services. The team can be reached before the event on:
 Tel +49 (0) 9 11. 86 06-80 00, Fax +49 (0) 9 11. 86 06-80 01.
 During the assembly times and during the event in the ExhibitorShop on site (Service 5/6, top floor) or in the foyer of hall 12 on:
 Tel +49 (0) 9 11. 86 06-80 05, Fax +49 (0) 9 11. 86 06-80 03.
 The respective location and the times are given in the Last Minute Information.
- 16. Exhibitors kitchens**
 Exhibitors requiring cold or warm water can use **twelve** kitchens set up for this purpose in the following areas during the event: basements of Service 1, hall 3, hall 3A, Service 4, Service 4/5, Service 7, hall 4A, hall 7A, Service 8/9, Service 9, hall 10, Service 12.0 Nord.
- 17. ExhibitorShop on site**
 Service 5/6, top floor
 In the ExhibitorShop on site, the Exhibition Services Team and Service-Partners of NürnbergMesse offer their services concentrated in one place to minimize the time spent by exhibitors obtaining information. The respective times at which they are present are given in the Last Minute Information.
- 18. Fire service**
 Form P2
 Exhibition Center Nuremberg, Feuerwache 5
 Fire service staff carry out inspection tours during the assembly period to check that stands comply with the fire prevention regulations. Accurate planning of stands in advance and compliance with instructions avoid delays and interruptions during assembly.
Please observe the fire prevention regulations and ensure that Form P2 is returned, if applicable.
- 19. First aid service**
 OperationCenter in the Exhibition Center Nuremberg
 Tel +49 (0) 9 11. 86 06-61 56
 Emergency Call at the Exhibition Center Nuremberg
 Tel +49 (0) 9 11. 70 00
- 20. Floral stand decoration and stand design, landscaping services**
 Forms S1.80, S1.82, S1.85
 The ServicePartners stay in the service areas of the halls in use until the start of the event.
- 21. Forwarding address**
 Event, hall, stand number, exhibitor
 Messezentrum, 90471 Nürnberg
- 22. Forwarding agent, transport services**
 Form S3.30
 Schenker Deutschland AG (Halls 3–7A)
 Kühne + Nagel (AG & Co.) KG (Halls 1, 2, 8–12)
 Safety and liability reasons require lifting equipment such as forklift trucks, cranes etc. to be requested solely via the respective exhibition forwarding agent.
 Please note: The minimum charging unit for personnel and equipment is 1.0 hour.
- 23. Furniture rental**
 Forms S1.50–S1.51, S1.60 – S1.67
- 24. getit! – Exhibition Services express**
 Takes care of the things you’ve forgotten that are not obtainable directly on the exhibition site – quickly and reliably!
 Tel +49 (0) 9 11. 86 06-80 90, getit@nuernbergmesse.de
- 25. Guarding of halls and stands**
 Form S3.40
 Engelhardt & Co. Sicherheit GmbH
 Exhibition halls are guarded during the official assembly and dismantling periods and for the duration of the event. However, this does not constitute any liability of the organizer. Additional stand guards are recommended and can only be ordered through the ServicePartner.
- 26. Hostesses/service personnel/helping hands, exhibition events, staff**
 Forms S4.30, S4.31, S4.40

- 27. Insurance**
Form S4.70
Insurance cover is recommended for exhibits and stand fittings.
The organizer can arrange exhibition insurance cover (transport and duration of event) and exhibitor liability insurance.
- 28. Lettering**
Forms S1.70, S1.71
- 29. Lift platforms** – see working platforms
- 30. Media and event equipment**
Forms S2.60, S2.61 and S2.62
MAS MEDIEN AKTIV SERVICE GmbH
pave GmbH
- 31. Medical assistance**
See Item 19 “First aid service”
Emergency services
Tel 1 12
- 32. Order confirmation**
Written confirmation is not issued in every case on receipt of service order forms. However, correspondence will follow on points in need of clarification.
- 33. Parking for exhibitors**
Form S3.50
- 33.1 Parking for cars**
The marked parking areas are available for parking cars. They are manned on the days of the event from 7:00 to 19:00 or until the end of the respective event each day.
Permanent parking permits are valid only for cars.
- 33.2 Parking for trucks, trailers, vans, etc.**
The parking of trucks, trailers, vans, swap bodies, caravans and mobile homes is prohibited during the exhibition in the areas marked as parking areas, in the loading yards of the Exhibition Center Nuremberg (except for delivery, which is restricted to a maximum of 30 minutes) and in the “Große Straße”. This regulation also applies to vehicles which give the impression of being trucks, trailers, vans, swap bodies, caravans and mobile homes.
Vehicles can be parked free of charge during the exhibition in the parking areas marked for this purpose by the organizer. The route to these parking areas only a few minutes drive from the Exhibition Center Nuremberg is signed and is also shown on the approach road maps handed out at the entrances to the loading yards.
The organizer is entitled to remove vehicles parked in the parking areas or the loading yards at 2:00 the morning of the first day of the event by having them towed away at the cost of the vehicle owner or user.
The exhibitor agrees to ensure that third parties appointed by him such as exhibition service companies, hauler etc. also comply with these regulations.
Please also see Item 45.
The display of advertisements, company signs etc. or any other publicity measures on the exhibitors or visitors car parks is prohibited.
- 34. Photography**
Only the ServicePartner is allowed to carry out commercial photography work during an event. Exhibitors can take photographs of their own stand as required. If a photographer other than the approved exhibition photographer Bischof & Broel, Tel +49 (0) 9 11. 53 35 33, is to be appointed to carry out commercial photography work, special permission at extra cost **must** be obtained from Exhibition Services by not later than three weeks before the start of the event. This also applies unconditionally for video and other film shootings and productions.
Please contact Exhibition Services, Tel +49 (0) 9 11. 86 06-84 45.
- 35. Public address announcements in halls**
In the interests of exhibitors and visitors, paging and advertising announcements in the halls are not permitted.
- 36. Refuse and waste disposal**
Form S3.21
Friedrich Hofmann Betriebsgesellschaft mbH
See Info 4 – “Guidelines for handling waste”
- 37. Signs, lettering**
Forms S1.70, S1.71
- 38. Scissor work platforms** – see working platforms
- 39. Sinks for use by painters**
Paint containers, paint brushes etc. are not to be washed out in the toilets and washrooms etc. Suitable rooms with sinks are provided in the basements of Service 1, 4, 4/5, 7, 8/9, 9 and in halls 3, 3A, 4A, 7A and 10–12.
- 40. Stand construction**
Forms SV.01, S0.10 – S1.19, S1.40, S1.45
:mesomondo GmbH
Holtmann Messe + Event
Messebau Wörnlein GmbH
- 41. Stand fittings, additional**
Forms S1.50 – S1.51, S1.60 – S1.67, S2.50
- 42. Taxi service**
Taxi ranks in the Exhibition Center Nuremberg at the entrance areas
Tel +49 (0) 9 11. 1 94 10
- 43. Telecommunications/Communication**
Forms S2.40 – S2.45
- 44. Toilets**
Toilet facilities are available free of charge.
- 45. Traffic and parking regulations**
Parking in the immediate vicinity of halls, especially in loading yards and in front of the exits is prohibited for all types of vehicles for the duration of the event. During the assembly and dismantling periods, vehicles may only halt in these areas for loading and unloading.
Access to interior areas is not possible at all. To prevent possible hindrance to the fire service, vehicles are to be removed immediately on completion of this work and can be parked on the designated parking areas.
Vehicle access to the loading yards is only possible on payment of a **deposit of EUR 100** (exception: trucks of 7.5 tons or more during dismantling). The deposit will be refunded if the vehicle leaves the loading yard within the time limits stated below.
Time limits during **assembly**:
● **1 hour** for loading and unloading cars and vehicles **up to 2.8 tons**
● **2 hours** for loading and unloading vehicles **over 2.8 tons**
Time limits during **dismantling**:
Vehicle access to the loading yards on the last day of the event is not possible from 13:00 until approx. 1 hour after the end of the exhibition due to delivery of empty containers by the exhibition forwarding agents.
Access is possible:
● **1 hour after the end of the exhibition**
for cars and vehicles **up to 2.8 tons**
● **2 hours after the end of the exhibition**
for vehicles **from 2.8 to 7.5 tons**
● **3 hours after the end of the exhibition**
for vehicles **over 7.5 tons**
Length of stay:
● **1 hour** for loading and unloading cars and vehicles **up to 2.8 tons**
● **2 hours** for loading and unloading vehicles **from 2.8 to 7.5 tons**
● **3 hours** (extension possible)
for loading and unloading vehicles **over 7.5 tons**
The exact access times may vary and are notified at the entrance gates.
- 46. Travel service, hotel reservations**
Forms S4.19, S4.20, S4.21
- 47. Water supply and drainage**
Form S2.30
August & Jean HILPERT Messe-Service GmbH (Halls 3–7)
Brochier Gebäudemanagement GmbH (Halls 1–2, 8–12)
- 48. Wireless LAN**
Form S2.46
available throughout the exhibition site, except parking areas.
WLAN powered by NürnbergMesse and Unity Deutschland GmbH & Co. KG
- 49. Working equipment** – see working platforms
- 50. Working platforms**
Form S3.32
For safety and liability reasons, working platforms etc. may only be requested via our ServicePartner SAG.

Your partners in the Exhibition Center Nuremberg

NürnbergMesse GmbH

Tel +49 (0) 9 11. 86 06-0, Fax +49 (0) 9 11. 86 06-82 28
info@nuernbergmesse.de/info@nuernberg-convention.de
www.nuernbergmesse.de

Exhibition Services

Tel +49 (0) 9 11. 86 06-80 00, Fax +49 (0) 9 11. 86 06-80 01
messeservice@nuernbergmesse.de
www.nuernbergmesse.de
www.standconfigurator.com

ServicePartner

1. Personally present in the ExhibitorShop on site

Service 5/6, top floor

In the ExhibitorShop on site, the Exhibition Services Team and ServicePartners of NürnbergMesse offer their services concentrated in one place to minimize the time spent by exhibitors obtaining information. The respective times at which they are present are given in the Last Minute Information.

:mesomondo GmbH

Stand construction, furniture rental, lettering, graphics, flooring
Tel +49 (0) 9 11. 40 08 35-0, Fax +49 (0) 9 11. 40 08 35-29
info@mesomondo.de, www.mesomondo.de

Holtmann Messe + Event

Stand construction
Tel +49 (0) 9 11. 86 06-60 50, Fax + 49 (0) 9 11. 86 06-60 59
nuernbergmesse@holtmann.de, www.holtmann.de

Hummel Möbelverleih GmbH

Furniture rental
Tel +49 (0) 9 11. 86 06-63 03, Fax +49 (0) 9 11. 86 06-63 04
nuernberg@hummel-mietmoebel.de, www.hummel-mietmoebel.de

Messebau Wörnlein GmbH

Stand construction, furniture rental, lettering, sundry materials, flooring,
flame retardant impregnation
Tel +49 (0) 9 11. 81 74 49-0, Fax +49 (0) 9 11. 81 74 49-25
info@woernlein.de, www.woernlein.de

2. Personally present in the ServicePartnerCenter

Brochier Gebäudemanagement GmbH

Plumbing installations
Tel +49 (0) 9 11. 9 81 29 78, Fax +49 (0) 9 11. 9 81 29 79
sp-messe-nbg@a-brochier.de, www.a-brochier.de

Business & Service Brigitte Schmedding GmbH

Hostesses, exhibition events and hotels
Tel +49 (0) 9 11. 8 60 76-0, Fax +49 (0) 9 11. 8 60 76-11
info@business-und-service.de, www.business-und-service.de

Engelhardt & Co. Parkraummanagement u. Service GmbH

Permanent parking permits for cars, travel tickets
Tel +49 (0) 9 11. 98 11 88-55, Fax +49 (0) 9 11. 98 11 88-58
info@engelhardt-parkservice.de, www.engelhardt-parkservice.de

Engelhardt & Co. Sicherheit GmbH

Guarding of stand
Tel +49 (0) 9 11. 98 11 88-0, Fax +49 (0) 9 11. 98 11 88-88
engelhardt@engelhardt-sicherheit.de, www.engelhardt-sicherheit.de

Foto Bischof & Broel KG

Photo service
Tel +49 (0) 9 11. 53 35 33, Fax +49 (0) 9 11. 55 05 03
bischof-und-broel@t-online.de, www.bischof-und-broel.de

August & Jean HILPERT Messe-Service GmbH

Plumbing installations
Tel +49 (0) 9 11. 37 66 38-0, Fax +49 (0) 9 11. 37 66 38-29
service@hilpert-messe.de, www.hilpert-messe.de

Friedrich Hofmann Betriebsgesellschaft mbH

Waste disposal
Tel +49 (0) 9 11. 8 12 82 96, Fax +49 (0) 9 11. 8 12 82 97
hofmann-denkt-messe@t-online.de, www.hofmann-denkt.de

Kiefer GmbH

Stand cleaning
Tel +49 (0) 9 11. 86 06-61 37, Fax +49 (0) 9 11. 9 81 72-30
info@kiefer-cleaning.de, www.kiefer-cleaning.de

Kühne + Nagel (AG & Co.) KG

Forwarding agent, transport services, container storage
Tel +49 (0) 9 11. 98 18 56-0, Fax +49 (0) 9 11. 98 18 56-29
exposervice.nuernberg@kuehne-nagel.com, www.kuehne-nagel.com

PAVE

Veranstaltungs- und Medientechnik
Tel +49 (0) 9 11. 86 06-60 11, Fax +49 (0) 9 11. 86 06-60 12
messe@pave.de, www.pave.de

SAG GmbH

Electricity supply, compressed air, ceiling suspensions, working platforms
Tel +49 (0) 9 11. 81 88 18-0, Fax +49 (0) 9 11. 81 88 18-19
sag-messe@sag.eu, www.sag-servicepartner.de

Schenker Deutschland AG

Forwarding agent, transport services, container storage
Tel +49 (0) 9 11. 8 17 48-0, Fax +49 (0) 9 11. 8 17 48-25
fairs.nuernberg@dbschenker.com, www.schenkerfairs.com

3. Restaurant Behaims, West and Ost

Lehrieder Catering-Party-Service GmbH & Co. KG
Exhibition and congress catering, event and stand catering
Tel +49 (0) 9 11. 86 06-61 14, Fax +49 (0) 9 11. 86 06-61 15
info@lehrieder.de, www.lehrieder.de

4. Mobile on site

Blumen Kuhn Floral design GmbH
Floral stand decoration, event decoration
Tel +49 (0) 9 11. 33 01 69, Fax +49 (0) 9 11. 20 94 83
messe@blumenkuhn.de, www.blumenkuhn.de

BSS Brandschutz Sichelstiel GmbH

Besprinklerung
Tel +49 (0) 9 11. 6 43 77 77 22, Fax +49 (0) 9 11. 6 43 77 77 50
volker.otto@brandschutz-sichelstiel.de, www.brandschutz-sichelstiel.de

dias Gebäudemanagement GmbH

Stand cleaning
Tel +49 (0) 9 11. 9 80 80 80, Fax +49 (0) 9 11. 9 80 80 81
nuernberg.messe@dias-service.de, www.dias-service.de

Gartengestaltung & Service Ronald Grabinger

Landscaping services, hand truck rental, rental of ladders
Tel +49 (0) 9 11. 86 06-52 24, Fax +49 (0) 9 11. 86 06-64 39
info@grabinger-gartenservice.de, www.grabinger-gartenservice.de

MAS MEDIEN AKTIV SERVICE GmbH

Media and event equipment
Tel +49 (0) 9 11. 60 00 93-0, Fax +49 (0) 9 11. 60 00 93-20
info@medien-aktiv-service.de, www.medien-aktiv-service.de

Bilfinger ProfiMiet München GmbH · NL Fürth

Rental crockery, dishwashing service
Tel +49 (0) 9 11. 99 94 42-0, Fax +49 (0) 9 11. 99 94 42-1 11
fuerth.profiemiet@bilfinger.com, www.profiemiet.bilfinger.com

Unify Deutschland GmbH & Co. KG

Communication, Internet, WLAN
Dr.-Mack-Straße 91, 90762 Fürth
Tel +49 (0) 9 11. 86 06-40 00/-48 48
communication@nuernbergmesse.de

Valentin Internationaler Messeservice GmbH & Co. KG

Kitchen appliances, refrigerated, freezing and catering equipment
Industriestraße 39, 40822 Mettmann
Tel +49 (0) 21 04. 91 03-0, Fax +49 (0) 21 04. 91 03-91
info@valentin-messeservice.com, www.valentin-messeservice.com

Nuremberg, Germany
14-16.3.2017



embeddedworld2017

Exhibition&Conference
... it's a smarter world

Return to
NürnbergMesse GmbH
Exhibition Team
Messezentrum
90471 Nürnberg

Fax +49 (0) 9 11. 86 06-12 85 86
embedded-world@nuernbergmesse.de

Company

Street

Postcode, Town, Country

Tel

Fax

E-mail

Return deadline
immediately

Hall/Stand

Person to contact

Tel

Fax

Invoice address (only if different)

Stand design (please complete or tick as appropriate)

- Our stand layout will conform to the stand assembly instructions. Approval of the plans is **not necessary**, as our stand construction height does not exceed 3.50 m.
- Our stand layout will conform to the stand assembly instructions. Approval of the plans is **necessary**, as our stand construction height exceeds 3.50 m.
- We will comply with the stand design guidelines. Approval of the plans is necessary as our stand space is at least 400 m².
- We confirm that all materials used comply with the following minimum standards: DIN 4102 B1 and DIN EN 13501 C (difficult to ignite), s2 (limited smoke production) and d0 (no droplets).
- Please send us Form P2 "Approval of deviations from the fire prevention regulations" as a PDF file by e-mail.

The following stand design plans in **1:50 or 1:100** scale are enclosed for approval

- Plans of side views showing **height**
- 3-D plan
- Layout plan with dimensions

The application for approval will only be processed if the exhibition team is in possession of all the plans stated above! 3 copies of the plans must be submitted for exhibition stands of 400 m² or more!

Please note that 2-storey stands are not permitted.

VAT ID number of exhibitor:

□□ □□□□□□□□□□□□□□

Our stand will be assembled by the following company:

Company

Address

Person to contact

Tel

Fax

E-mail

Internet

Approval by NürnbergMesse exhibition team:

Plan dated:

Plan no.:

Date

Signature

Place and date

Company stamp and authorized signature

Approval of deviations from the fire prevention regulations

P2

Nuremberg, Germany
14–16.3.2017



embeddedworld2017

Exhibition&Conference
... it's a smarter world

Return to
NürnbergMesse GmbH
Exhibition Team
Messezentrum
90471 Nürnberg

Fax +49 (0) 9 11. 86 06-12 85 86
embedded-world@nuernbergmesse.de

Company

Street

Postcode, Town, Country

Tel

Fax

E-mail

Return deadline
immediately

Hall/Stand

Person to contact

Tel

Fax

Invoice address (only if different)

Application for equipment and installations requiring registration, inspection and approval by the Nuremberg fire prevention authorities

(In compliance with the fire prevention and safety regulations, see Info 4, 4.4 – “Fire prevention and safety regulations“.)

Our stand contains the following equipment or installations, which according to the enclosed fire prevention and safety regulations require approval by the Nuremberg fire prevention authorities:

(Please tick)

- Stand with **> 30 m² closed** ceiling area, partly certified, sprinkler-compatible material or alternative measure.
- Decoration material** does not comply with **at least** construction products Class B1 or Euroclass B or C (floorings, wall coverings, decoration, ceiling material)
- Compressed gas cylinders** (on principle)
- Actions involving **fire hazard** (cutting, welding, soldering, grilling, heating, candles, fire gel,...)
- Exhibits involving **fire hazard** (ovens, burners, pellets,...)
- Notifiable** equipment (laser equipment, x-ray machines)
- Pyrotechnic** demonstrations (fireworks, fog machine,...)
- Synthetic materials** (polystyrene, acrylic glass, films,...)
- Combustible** liquids (petrol, oils, fats, alcohols,...)
- Exhaust gas emissions** (engines/heating stoves,...)
- Miscellaneous/description:** _____

Inquiries:

NürnbergMesse GmbH
Bereich Veranstaltungstechnik
Messezentrum
90471 Nürnberg
standgenehmigung@nuernbergmesse.de

Conditions imposed by NürnbergMesse:

Approved, date

Signature

Conditions imposed by responsible fire prevention authority:

Approved, date

Signature, stamp

Place and date

Company stamp and authorized signature

Nuremberg, Germany
14–16.3.2017



embeddedworld2017

Exhibition&Conference
... it's a smarter world

Return to
NürnbergMesse GmbH
Exhibition Team
Messezentrum
90471 Nürnberg

Fax +49 (0) 9 11. 86 06-12 85 86
embedded-world@nuernbergmesse.de

Company _____

Street _____

Postcode, Town, Country _____

Tel _____

Fax _____

E-mail _____

Return deadline _____

Hall/Stand _____

immediately

Person to contact/Stand manager _____

Tel _____

Fax _____

Invoice address (only if different) _____

Use of stand after exhibition closes

We are planning a stand party on:

Wednesday, 15.3.2017

Time (not before exhibition closes, not later than 22:00)

from _____ p.m. to _____ p.m.

Number of participants expected: approx. _____ persons

Price for organizing a stand party: EUR 510
Price plus VAT at the statutory rate.

The price includes hall lighting and hall cleaning and security and cloakroom staff and event director.

Please order your stand cleaning requirements under Logistics/Cleaning of stand.

Do you intend to appoint companies that are not ServicePartners of NürnbergMesse?

Company 1 _____

Person to contact _____

Tel _____ Fax _____

Company 2 _____

Person to contact _____

Tel _____ Fax _____

You must give the contact person of the above-named company a copy of the approval of the stand party, which then serves as a permit for access to the loading yards. Exhibition activity must not be disturbed by preparations for your stand party before 18:00

VAT ID number of exhibitor:

We recommend the ServicePartner of NürnbergMesse for stand catering:

Lehrieder Catering-Party-Service
GmbH & Co. KG
Messezentrum 1, 90471 Nürnberg
Tel +49 (0) 9 11. 86 06-61 14
Fax +49 (0) 9 11. 86 06-61 15
info@lehrieder.de
www.lehrieder.de

Information for exhibitors on using stands after the exhibition closes:

- Stand parties are governed by the Bavarian Venue Regulations (BayVStättV), which are to be complied with by the respective exhibitor. The exhibitor is therefore obliged to order the services of an event director. These services and the employee of the security company are included in the package booked. The person performs the functions of event director. The event director must be personally present on the site for the whole duration of the stand party. The event director is responsible for performing the operator's duties; i.e. in the event of a risk to public safety and order, the event director is to stop the event if necessary. Instructions issued by the event director must be obeyed. The exhibitor is also responsible for ensuring compliance with the NürnbergMesse site regulations, all technical regulations, especially fire regulations, and all other rules. The exhibitor shall be familiar with the text of the site regulations, which are on display, and the obligations of the Bavarian Venue Regulations.
- Shuttle buses are available to the car parks until one hour after the exhibition closes.
- NürnbergMesse shall not be liable if the event is terminated by the event director on the grounds of the Bavarian Venue Regulations (BayVStättV). The right of NürnbergMesse to terminate the use of the stand/the stand party remains unaffected if the exhibitor contravenes the Site Regulations or public regulations, particularly the Bavarian Venue Regulations.
- Recorded or live musical performances must not disturb persons on the neighboring stands. Musical performances may not commence until at least 30 minutes after the exhibition closes. Musical performances are subject to GEMA fees for performance rights. The exhibitor is responsible for arranging GEMA registration (GEMA-Bezirksdirektion Stuttgart (Key Account Management, Herdweg 63, 70174 Stuttgart, Tel +49 (0) 7 11. 22 52-7 94, Fax +49 (0) 7 11. 22 52-8 00, messe@gema.de, www.gema.de).
- The volume measured one meter from the edge of the stand must not exceed 70 dB (A).
- Guests entering the exhibition site before the exhibition closes need a valid entrance ticket. Guests entering the exhibition site after the exhibition closes need a written invitation from the exhibitor.
No admission without an invitation!
- The number of security guards depends on the size of the event. This ensures that the planned activities do not affect neighboring stands. The exhibitor will be charged for any damage caused to neighboring stands due to the stand party. NürnbergMesse arranges the order for security guards. NürnbergMesse accepts no liability for cloakrooms and theft.

We request approval for organizing a stand party and accept the contractual terms.

Place and date

Company stamp and authorized signature

Registration of exhibitor's own WLAN access point on the stand

P5

Nuremberg, Germany
14-16.3.2017



embeddedworld2017

Exhibition&Conference

... it's a smarter world

Return to
NürnbergMesse GmbH
MesseService
Messezentrum
90471 Nürnberg
Tel +49 (0) 9 11. 86 06-80 10
Fax +49 (0) 9 11. 86 06-80 01
communication@nuernbergmesse.de

Company

Street

Postcode, Town, Country

Tel

Fax

E-mail

Return deadline
immediately

Hall/Stand

Person to contact

Tel

Fax

Invoice address (only if different)

I hereby register with:

NürnbergMesse GmbH
MesseService
Messezentrum
90471 Nürnberg

VAT ID number of exhibitor:

<input type="text"/>	<input type="text"/>	<input type="text"/>	<input type="text"/>	<input type="text"/>	<input type="text"/>	<input type="text"/>	<input type="text"/>	<input type="text"/>	<input type="text"/>	<input type="text"/>	<input type="text"/>	<input type="text"/>	<input type="text"/>	<input type="text"/>	<input type="text"/>	<input type="text"/>	<input type="text"/>	<input type="text"/>	<input type="text"/>
----------------------	----------------------	----------------------	----------------------	----------------------	----------------------	----------------------	----------------------	----------------------	----------------------	----------------------	----------------------	----------------------	----------------------	----------------------	----------------------	----------------------	----------------------	----------------------	----------------------

Please send fax reply to:

Fax +49 (0) 9 11. 86 06-80 01

Any questions?

Tel +49 (0) 9 11. 86 06-80 10

Exhibitors are only permitted to operate their own WLAN (Wireless Local Area Network) subject to the explicit written authorization of NürnbergMesse GmbH. The following technical requirements must be observed and will help you do your part to ensure that a large bandwidth is available for all users in the WLAN network and that faults are largely avoided. For this reason every WLAN is assigned to a fixed channel. Registration includes channel planning and monitoring.

- Only one access point per channel is allowed.
- WLAN transmitters in the 5 GHz band are not permitted.
- **You must use the assigned channel.**
- **Channel bonding is not permitted.**
- The radiated transmit power must not exceed -80 dBm at the edge of the stand.
- An encryption (e.g. WPA2) according to the latest technical standards is mandatory.
- Your own SSID must be visible and login data must not be disclosed to third parties.
- Only WLAN transmitters are to be operated, no other transmitters.

For registration and channel planning we charge you a one-off fee of EUR 125 plus VAT at the statutory rate.

If an exhibitor operates their own equipment **that has not been registered**, NürnbergMesse GmbH reserves the right to prohibit operation. Claims for damages may be enforced in the event of contravention. Registration does not guarantee the functional reliability and operation of the customer's own WLAN network. Orders received at short notice (< 14 days before the start of the event) will be subject to an express processing surcharge amounting to 25 % of the ordered value.

Your details

SSID (WLAN Network Name):

No. of WLAN users

Contact for technical queries:

Company (if different)

Address

Contact person

Tel.

E-mail

Mobil

The customer attests to the correctness of the information provided and acknowledges that in the event of incorrect or incomplete data, NürnbergMesse GmbH shall have the right to block the connection.

Comments:

Place and date

Company stamp and authorized signature

Nuremberg, Germany
14-16.3.2017



embeddedworld2017

Exhibition & Conference
... it's a smarter world

Return to
NürnbergMesse GmbH
MesseService
Messezentrum
90471 Nürnberg
Tel +49 (0) 9 11. 86 06-80 00
Fax +49 (0) 9 11. 86 06-80 01
messeservice@nuernbergmesse.de

Company _____

Street _____

Postcode, Town, Country _____

Tel _____

Fax _____

E-mail _____

Return deadline	Hall/Stand
immediately	
Person to contact _____	
Tel _____	
Fax _____	
Invoice address (only if different) _____	

Rental exhibition stand

- We have already ordered a complete rental stand (including 3 kW power supply and consumption) in addition to the stand space on the application form for embedded world 2017.
- We order a complete rental stand (including 3 kW power supply and consumption) and choose a complete rental stand from Forms SV.01, S0.10 – S0.99 and return the completed form.
- We order a basic rental exhibition stand (excluding 3 kW power supply and consumption) and choose a rental stand from Forms S1.10 – S1.15 and return the completed form.
- We will use a stand from another stand construction company (**please note Info 1, Item 7 "Stand layout"**).
- We will build our own stand (**please note Info 1, Item 7 "Stand layout"**).

VAT ID number of exhibitor:

--	--	--	--	--	--	--	--	--	--	--	--	--	--	--	--	--	--	--	--

This form must be returned in all cases, as we need information about your stand construction and design.

Stand partition walls

If none of the above-mentioned stands will be used, stand partition walls (2.50 m high) must be erected on all closed sides of the stand space.

We need stand partition walls and therefore order the following (the information you have given in the application form does not constitute an order):

- Stand partition walls **white, plastic-coated** meroform system, built by Wörnlein *, approx. 3 cm thick, minimum height approx. 2.50 m, at EUR 31.50 per wall element (max. 1.00 m wide).

It may be necessary for structural reasons to fit support walls (at extra cost). 1 supporting wall is charged for every full 5 meter length of walls. These support walls can **only** be removed on the organizer's instructions.

Please provide a plan when ordering stand partition walls or a rental stand.

All prices stated are subject to the addition of **VAT at the statutory rate** and 3 % **insurance premium**.

- We do not require insurance and accept liability for the stand and rented objects.

Orders received later than 14 days before the start of the event will be billed an express surcharge of 25 %, subject to a minimum surcharge of EUR 10 per order.

* If necessary, NürnbergMesse is entitled to have the service ordered provided by another ServicePartner. In this case, the customer will be notified of the other ServicePartner in good time.

With our authorized signature below, we acknowledge acceptance of all items of the General and Special Terms of Business of NürnbergMesse and the General Terms of Business and the Special Conditions for Services of the ServicePartner.

Place and date

Company stamp and authorized signature

Choose the fast way – rental stand, electricity supply and pre-show cleaning with one order! Plus the option of daily stand cleaning at an attractive price per m².



Complete rental stand **embedded 1**
Complete price **EUR 62.40/m²**

See Form **SV.01**



Complete rental stand **embedded 2**
Complete price **EUR 62.40/m²**

See Form **SV.01**



Complete rental stand **JUNO**
Complete price **EUR 69.90/m²**
Minimum size **9 m²**

See Form **S0.10**



Complete rental stand **PALLAS**
Complete price **EUR 69.90/m²**
Minimum size **9 m²**

See Form **S0.11**



Complete rental stand **MARS**
Complete price **EUR 86.90/m²**
Minimum size **9 m²**

See Form **S0.20**



Complete rental stand **MERCURY**
Complete price **EUR 86.90/m²**
Minimum size **9 m²**

See Form **S0.21**



Complete rental stand **EARTH**
Complete price **EUR 107.50/m²**
Minimum size **9 m²**

See Form **S0.30**



Complete rental stand **MOON**
Complete price **EUR 107.50/m²**
Minimum size **9 m²**

See Form **S0.31**



Complete rental stand **HELIOS**
Complete price **EUR 128.90/m²**
Minimum size **15 m²**

See Form **S0.50**



Complete rental stand **OBERON**
Complete price **EUR 128.90/m²**
Minimum size **15 m²**

See Form **S0.51**



Complete rental stand **APOLLO**
Complete price **EUR 138.90/m²**
Minimum size **20 m²**

See Form **S0.40**



Complete rental stand **POLLUX**
Complete price **EUR 138.90/m²**
Minimum size **20 m²**

See Form **S0.41**

All prices are subject to the addition of VAT at the statutory rate.
More stands (excluding electricity supply) can be found on Forms S1.10 ff.

All complete rental stands at a glance

Choose the fast way – rental stand, electricity supply and pre-show cleaning with one order! Plus the option of daily stand cleaning at an attractive price per m².



Complete rental stand **CALYPSO**
Complete price **EUR 144.90/m²**
Minimum size **15 m²**

See Form **S0.60**



Complete rental stand **KALLISTO**
Complete price **EUR 144.90/m²**
Minimum size **15 m²**

See Form **S0.61**



Complete rental stand **SIRIUS**
Complete price **EUR 157.90/m²**
Minimum size **28 m²**

See Form **S0.70**



Complete rental stand **PLUTO**
Complete price **EUR 151.50/m²**
Minimum size **24 m²**

See Form **S0.71**



Complete rental stand **SATURN**
Complete price **EUR 187.50/m²**
Minimum size **28 m²**

See Form **S0.95**

Now with 6 kW electricity supply



Complete rental stand **VESTA**
Complete price **EUR 171.00/m²**
Minimum size **15 m²**

See Form **S0.81**



Complete rental stand **SUN**
Complete price **EUR 232.50/m²**
Minimum size **28 m²**

See Form **S0.99**

Now with 6 kW electricity supply



Individual stand design

See Form **S1.40**

You can use our practical online aid on the Internet at **www.standconfigurator.com** to visualize the shape, color and equipment of your personal exhibition stand. We will be pleased to advise **you** personally:

Tel +49 (0) 9 11. 86 06-80 00 or messeservice@nuernbergmesse.de

Nuremberg, Germany
14–16.3.2017



Please return to
NürnbergMesse GmbH
Exhibition Team
Messezentrum
90471 Nürnberg
F +49 9 11 86 06-12 85 86
embedded-world@nuernbergmesse.de

Contractor*
Complete rental stand embedded 1
:mesomondo GmbH

Complete rental stand embedded 2
Messebau Wörnlein GmbH

Return deadline
14.12.2016

Company name of direct exhibitor _____
Street _____
Postcode, Town, Country _____
Tel. _____ Fax _____
E-mail _____
Internet _____
VAT Reg No

Person to contact _____
Tel. _____ Fax _____
E-mail _____
Invoice address/Authorized recipient (only if different)
(see item 9 of the Special Conditions for Participation) _____

Order (please tick as appropriate)

Complete rental stand embedded 1

Complete rental stand embedded 2



The rental for the duration of the event includes the following equipment:

Walls
white plastic-coated stand partition walls with aluminum frame on all closed sides of the stand space (Syma system; 2.50 m high)
Ribbed carpet
including eding tape, disposal and dust sheet, in anthracite
or: red blue gray
Aluminum colored lattice support with slide in fascia
on all open sides of stand space
slide in fascia (0.29 m height) in blue
or: red white

Round column
at all open corners of stand space in blue
or: red white

Lettering (brief company name and place of business)
Helvetica medium, black (with white back ground, otherwise white lettering – including 20 letters)
Logo: price on demand.

Additional packages (only in connection with complete rental stand embedded 1):
Cubicle 1 x 1 m²
with lockable door
 at extra cost EUR 95.50
Cubicle 2 x 1 m²
with lockable door
 at extra cost EUR 107.90
Furniture set "CUBUS 13"
3 chairs
with table 0.70 x 0.70 m, white
 at extra cost EUR 69.50
Furniture set "Zeus"
2 bar stools "Zeta"
with high table "Roma", aluminum, round 0.60 m diameter
 at extra cost EUR 91.50
Furniture set "Poseidon"
1 information counter (not lockable),
1 bar stool "Zeta",
1 leaflet stand
 at extra cost EUR 152.90
Lighting package
3 halogen spotlights 150/80 Watt,
on power rail, mounted on fascia
 at extra cost EUR 101.50
Power supply
rated at 3 kW (AC) incl. consumption
and 3-way mains socket
Including removal and disposal of
carpet dust sheet and **basic cleaning**
before the start of the exhibition



The rental for the duration of the event includes the following equipment:

Walls
white plastic-coated stand partition walls on all closed sides of the stand space (Syma system; 2.50 m high), plain or:
 perforated
Needle-felt carpet
including eding tape, disposal and dust sheet, in anthracite or:
 red blue gray
Chrome lattice support with fascia
on all open sides of stand space
 trapezoidal fascia (1.93 x 0.47 m), white or alternatively: red
 rectangular fascia (1.50 x 0.75 m), white or alternatively: blue
Corner column
at all open corners of stand space in white or: red blue
Lettering (brief company name and place of business)
Helvetica medium, black (with white back ground, otherwise white lettering – including 20 letters)
Logo: price on demand.

Additional packages (only in connection with complete rental stand embedded 2):
Cubicle 1 x 1 m²
with lockable door
 at extra cost EUR 95.50
Cubicle 2 x 1 m²
with lockable door
 at extra cost EUR 107.90
Furniture set "CUBUS 23"
3 chairs
with table 0.70 x 0.70 m, white
 at extra cost EUR 71.50
Furniture set "Quadro"
2 bar stools "Z" with high table, round 0.70 m diameter, white
 at extra cost EUR 88.90
Furniture set "Information"
1 information counter (not lockable),
1 bar stool "Z",
1 leaflet stand
 at extra cost EUR 152.90
Lighting package
3 halogen spotlights 150 Watt, individually adjustable
 at extra cost EUR 101.50
Power supply
rated at 3 kW (AC) incl. consumption and 3-way mains socket
Including removal and disposal of
carpet dust sheet and **basic cleaning**
before the start of the exhibition

Text for lettering on fascia:

*If necessary, NürnbergMesse is entitled to have the service ordered provided by another ServicePartner.
 Yes, we order daily cleaning during the exhibition at a total extra price of EUR 1.65/m².
 Power rating increased from 3 kW to 6 kW (AC): surcharge EUR 159.00. Power rating increased from 3 kW to 9 kW (AC): surcharge EUR 220.00.
Orders received later than 14 days before the start of the event will be billed an express surcharge of 25%, subject to a minimum surcharge of EUR 10 per order.
All prices plus 3% **insurance premium**.
 No, we do not require insurance and accept liability for the stand and hired objects.
Unless otherwise indicated, all prices stated are subject to statutory VAT if the service is taxable in Germany.
We accept all items of the enclosed Special and General Conditions for Participation.

Complete rental stand JUNO

S0.10

Nuremberg, Germany
14-16.3.2017



embeddedworld2017

Exhibition & Conference
... it's a smarter world

Return to
NürnbergMesse GmbH
MesseService
Messezentrum
90471 Nürnberg
Tel +49 (0) 9 11. 86 06-80 00
Fax +49 (0) 9 11. 86 06-80 01
messeservice@nuernbergmesse.de

Contractor *
:mesomondo GmbH
Messezentrum 1
90471 Nürnberg
Tel +49 (0) 9 11. 40 08 35-0
Fax +49 (0) 9 11. 40 08 35-29
info@mesomondo.de
www.mesomondo.de

Return deadline
14.12.2016

Hall/Stand

Company

Street

Postcode, Town, Country

Tel

Fax

E-mail

Person to contact

Tel

Fax

Invoice address (only if different)

Order

Stand type (Please enclose plan):



in-line stand



corner stand



head stand



block stand

Stand size: front _____ m x depth _____ m **minimum size: 9 m²**

The rental for the duration of the event includes the following equipment:

Walls

white, plastic-coated stand partition walls on all closed sides of stand space (Syma system, 2.50 m high)

Carpet, anthracite

ribbed, including edging tape, dust sheet and disposal

Cubicle

diagonal, with curtain, light gray
 or at extra cost 1 lockable hinged door, white EUR 47.90

Graphic panel above cubicle

2.00 x 1.00 m², white with aluminum frame, size of lettering area 1.96 x 0.90 m

Lettering

company name in Helvetica medium, black, letter height if possible 75 or 100 mm

Lighting

1 x 130 watt extending spotlight per full 4 m² of stand space (at least 3 spots)

Furniture

1 counter, 0.92 x 0.52 x 1.05 m;
white; lockable EUR 75.40
 1 coat rack EUR 19.90
 1 waste paper basket EUR 8.70

Power supply

in the cubicle, rated at 3 kW (AC), including consumption and 3-way mains socket,

- Power rating increased from 3 kW to 6 kW (AC) surcharge EUR 167.50
- Power rating increased from 3 kW to 9 kW surcharge EUR 237.00

Power supply of more than 9 kW – see Online ExhibitorShop under Technical Services – Electricity supply. (PDF Form S2.10)

NEW! Including pre-show cleaning before the start of the exhibition, including removing and disposal of carpet dust sheet.

Furniture group CUBUS 1

Only in conjunction with rental stand JUNO
Table round; diameter 0.70 m, chair upholstered

- Group with 3 chairs EUR 69.50
- Group with 4 chairs EUR 82.00



VAT ID number of exhibitor:

<input type="text"/>	<input type="text"/>	<input type="text"/>	<input type="text"/>	<input type="text"/>	<input type="text"/>	<input type="text"/>	<input type="text"/>	<input type="text"/>	<input type="text"/>	<input type="text"/>	<input type="text"/>	<input type="text"/>	<input type="text"/>	<input type="text"/>	<input type="text"/>	<input type="text"/>	<input type="text"/>	<input type="text"/>	<input type="text"/>
----------------------	----------------------	----------------------	----------------------	----------------------	----------------------	----------------------	----------------------	----------------------	----------------------	----------------------	----------------------	----------------------	----------------------	----------------------	----------------------	----------------------	----------------------	----------------------	----------------------



Complete price EUR 69.90/m²
incl. power supply rated at 3 kW, consumption and pre-show cleaning

Tel +49 (0) 9 11. 86 06-80 00 or
messeservice@nuernbergmesse.de

Additional services, special equipment and individual requirements are obtainable on request and can be ordered overleaf.

Text for lettering on fascia:

<input type="text"/>	<input type="text"/>	<input type="text"/>	<input type="text"/>	<input type="text"/>	<input type="text"/>	<input type="text"/>	<input type="text"/>	<input type="text"/>	<input type="text"/>	<input type="text"/>	<input type="text"/>	<input type="text"/>	<input type="text"/>	<input type="text"/>	<input type="text"/>	<input type="text"/>	<input type="text"/>	<input type="text"/>	<input type="text"/>
<input type="text"/>	<input type="text"/>	<input type="text"/>	<input type="text"/>	<input type="text"/>	<input type="text"/>	<input type="text"/>	<input type="text"/>	<input type="text"/>	<input type="text"/>	<input type="text"/>	<input type="text"/>	<input type="text"/>	<input type="text"/>	<input type="text"/>	<input type="text"/>	<input type="text"/>	<input type="text"/>	<input type="text"/>	<input type="text"/>

Orders received later than 14 days before the start of the event will be billed an express surcharge of 25 %, subject to a minimum surcharge of EUR 10 per order.

Yes, we order daily cleaning during the exhibition at a total extra price of EUR 1.65/m².

All prices stated are subject to the addition of VAT at the statutory rate and 3 % insurance premium.

* If necessary, NürnbergMesse is entitled to have the service ordered provided by another ServicePartner. In this case, the customer will be notified of the other ServicePartner in good time.

With our authorized signature below, we acknowledge acceptance of all items of the General and Special Terms of Business of NürnbergMesse and the General Terms of Business and the Special Conditions for Services of the ServicePartner.

We do not require insurance and accept liability for the stand and rented objects.

Place and date

Company stamp and authorized signature

Additional equipment
Complete rental stand JUNO

Order

All the articles stated below are charged directly by the ServicePartner:

- Digital print for graphic panel, (2.00 x 1.00 m)
Exhibitor must provide print data 20 days before the event EUR 126.10
- Increasing height of one stand partition wall by one panel, 1.00 x 1.00 m including digital print EUR 89.80
- Increasing height of one stand partition wall by one panel, 1.00 x 1.00 m, including 2-color film plot EUR 60.10
- Increasing height of one stand partition wall by one panel, 1.00 x 1.00 m, including 1-color film plot EUR 53.60



Design examples with articles at extra cost:



Additional stand equipment can be found at www.mesomondo.de.

All prices

are subject to the addition of VAT at the statutory rate and 3 % insurance premium for stand material and furniture.

- We do not require insurance and accept liability for damage and loss.

Services on request

The following hourly flat rates are charged plus VAT at the statutory rate:

- 1. Working hour at EUR 49.50

The organizer is responsible for assembling and dismantling the JUNO complete rental stand.

The complete rental stand and its equipment must not be pasted over, nailed, painted or damaged in any other way.

The exhibitor is liable for damage caused during the rental period and will be charged with the costs.

The charges for additional equipment are invoiced by the ServicePartner.

Remarks: _____

Orders received later than 14 days before the start of the event will be billed an express surcharge of 25 %, subject to a minimum surcharge of EUR 10 per order.

With our authorized signature below, we acknowledge acceptance of all items of the General and Special Terms of Business of NürnbergMesse and the General Terms of Business and the Special Conditions for Services of the ServicePartner.

Place and date

Company stamp and authorized signature

Nuremberg, Germany
14-16.3.2017



embeddedworld2017

Exhibition & Conference
... it's a smarter world

Return to
NürnbergMesse GmbH
MesseService
Messezentrum
90471 Nürnberg
Tel +49 (0) 9 11. 86 06-80 00
Fax +49 (0) 9 11. 86 06-80 01
messeservice@nuernbergmesse.de

Contractor *
Messebau Wörnlein GmbH
Messezentrum
90471 Nürnberg
Tel +49 (0) 9 11. 81 74 49-0
Fax +49 (0) 9 11. 81 74 49-25
info@woernlein.de
www.woernlein.de

Company
Street
Postcode, Town, Country
Tel
Fax
E-mail

Return deadline
14.12.2016

Hall/Stand

Person to contact
Tel
Fax
Invoice address (only if different)

Order

Stand type (Please enclose plan):

- in-line stand
corner stand
head stand
block stand

Stand size: front m x depth m minimum size: 9 m²

The rental for the duration of the event includes the following equipment:

- Walls: white, plastic-coated stand partition walls...
Magnetic whiteboard: 1 wall element, width 1.00 m...
Additional equipment: whiteboard marker, black and blotter or 10 magnetic clamps
Carpet: needle-felt, including edging tape, dust sheet and disposal, gray or: blue red
2 lettering panels: 1.00 x 1.00 m, white or alternatively: gray blue red
Lettering: company name and place of business in Helvetica medium...
Lighting: 1 extending spotlight "Collus", 130 W, per full 4 m² of stand space...
Cubicle: 1.00 x 1.00 m with lockable hinged door EUR 95.50
Furniture: 1 counter 1.05 x 0.55 x 1.05 m; white; not lockable EUR 75.40
1 coat rack with 5 hooks EUR 18.50
1 waste paper basket EUR 8.70
Power supply: in the corner, rated at 3 kW (AC), including consumption and 3-way mains socket
Power supply of more than 9 kW - see Online ExhibitorShop under Technical Services - Electricity supply. (PDF Form S2.10)
NEW! Including pre-show cleaning before the start of the exhibition, removing and disposal of carpet dust sheet.
Continued overleaf!

VAT ID number of exhibitor:

VAT ID number input boxes



Complete price EUR 69.90/m² incl. power supply rated at 3 kW, consumption and pre-show cleaning

Tel +49 (0) 9 11. 86 06-80 00 or messeservice@nuernbergmesse.de

Additional services, special equipment and individual requirements are obtainable on request and can be ordered overleaf.

Text for lettering on fascia:

Text for lettering input boxes

Orders received later than 14 days before the start of the event will be billed an express surcharge of 25 %, subject to a minimum surcharge of EUR 10 per order.

Yes, we order daily cleaning during the exhibition at a total extra price of EUR 1.65/m².
All prices stated are subject to the addition of VAT at the statutory rate and 3 % insurance premium.
* If necessary, NürnbergMesse is entitled to have the service ordered provided by another ServicePartner.
With our authorized signature below, we acknowledge acceptance of all items of the General and Special Terms of Business of NürnbergMesse and the General Terms of Business and the Special Conditions for Services of the ServicePartner.
We do not require insurance and accept liability for the stand and rented objects.

Place and date

Company stamp and authorized signature

Order (continued)

Furniture group CUBUS 2

Only in conjunction with rental stand PALLAS

Table round; diameter 0.70 m,
chair "Opus"



- Group with 3 chairs EUR 71.50
- Group with 4 chairs EUR 82.50

Additional equipment
Complete rental stand PALLAS

Order

All the articles stated below are charged direct by the ServicePartner:

1. Exclusive variations

Additional whiteboard (each)

Surcharge
 EUR 80.60

Additional shelf (each)

white EUR 20.40

Additional (each)

Bar stool "Z"
 black EUR 25.00
 white EUR 25.00

Additional extending spotlight (each)

"Collus", 130 W EUR 39.00

Graphics for lettering panels

Surcharge for logo instead of lettering (standard) graphics data has to be sent by the exhibitor. 2 pieces à 1.00 x 1.00 m
 EUR 49.20

2. Color digital printing (per m²)

on paper 140-190 g/ m²
(without mounting)
 EUR 38.30

on self-adhesive film
(without mounting, without protection film)
 EUR 52.00

Data formats: printable PDF files; also EPS (vector format, fonts converted into paths).

Print lead time: 4 weeks prior to start of exhibition.

In the case of data that cannot be printed directly, processing fees of EUR 83.80/hour apply.

See Online [ExhibitorShop](#) / [Stand Construction](#) – [Lettering/Prints](#) – [Fascia Lettering](#) (contractor: Messebau Wörnlein GmbH). (PDF Form S1.71)

More stand equipment components – see Online ExhibitorShop under [Stand Construction](#) – [Extra stand equipment / floor coverings / furniture](#) – [Stand equipment](#) (contractor: Messebau Wörnlein GmbH). (PDF Forms S1.64 – 1.66)

All prices are subject to the addition of VAT at the statutory rate and 3 % insurance premium for stand material and furniture.

We do not require insurance and accept liability for damage and loss.

Services on request

The following hourly flat rates are charged plus VAT at the statutory rate:

- 1. Installation hour at EUR 43.40
- 2. Workshop hour at EUR 41.80
- 3. Machine hour at EUR 61.70

The organizer is responsible for assembling and dismantling the PALLAS complete rental stand.

The complete rental stand and its equipment must not be pasted over, nailed, painted or damaged in any other way.

The exhibitor is liable for damage caused during the rental period and will be charged with the costs.

The charges for additional equipment are invoiced by the ServicePartner.

Remarks: _____

Design examples with articles at extra cost:



Orders received later than 14 days before the start of the event will be billed an express surcharge of 25 %, subject to a minimum surcharge of EUR 10 per order.

With our authorized signature below, we acknowledge acceptance of all items of the General and Special Terms of Business of NürnbergMesse and the General Terms of Business and the Special Conditions for Services of the ServicePartner.

Place and date

Company stamp and authorized signature

Order (continued)

Power supply

in the cubicle, rated at 3 kW (AC), including consumption and 3-way mains socket.

- Power rating increased from 3 kW to 6 kW (AC) surcharge EUR 167.50
- Power rating increased from 3 kW to 9 kW surcharge EUR 237.00

Power supply of more than 9 kW – see Online ExhibitorShop under Technical Services – Electricity supply. (PDF Form S2.10)

NEW! Including pre-show cleaning

before the start of the exhibition, including removing and disposal of carpet dust sheet.

Additional equipment
Complete rental stand MARS

Order

1. Exclusive variations

- 1.1 False floor (per m²)**
63 mm clipboard; suitable for laying cables below; aluminum edging strip
 EUR 14.45
- 1.2 Wall cladding (per m)**
without visible supports, height 2.50 m (surcharge). These walls are just asking to be used for graphics.
 EUR 32.00
- 1.3 Larger cubicle (per m²):**
 additional space EUR 41.60

2. Additional stand equipment

- 2.1 Product display units (each):**
Dialog shelf unit
2.50 x 0.96 m; silver; 5 shelves
 EUR 122.80
- 2.2 Additional furniture (each):**
Table
chrome frame with white top 0.70 x 0.70 m
 EUR 28.00
Upholstered chair "FAKT"
 black EUR 21.20
 anthracite EUR 21.20
- 2.3 Additional spotlights (each)**
 130 W EUR 39.00

3. Logo/graphics

- 3.1 Graphics at the wall (per m²)**
digital printing, mounted professionally at the wall
 EUR 62.00
 - 3.2 Slide-in fascia (surcharge per logo):**
Logo as digital print (per m)
 EUR 20.50
 - 3.3 Design element:**
Digital print
 EUR 46.15
- The data for logos and printing – as vectorized file (.eps or .ai) with 300 dpi in 1:10 format – must be received by not later than 20 days before the event!**

Floral stand decoration – see Online ExhibitorShop under Stand Construction – Floral stand decoration / landscaping services.

Exclusive and additional equipment can be seen in the stand configurator at **www.standconfigurator.com**. Additional stand equipment can be found at **www.mesomondo.de**.

All prices are subject to the addition of VAT at the statutory rate and 3 % insurance premium for stand material and furniture.
 We do not require insurance and accept liability for damage and loss.

Services on request
The following hourly flat rates are charged plus VAT at the statutory rate:

- 1. Working hour** at EUR 49.50
The organizer is responsible for assembling and dismantling the MARS complete rental stand.
The complete rental stand and its equipment must not be pasted over, nailed, painted or damaged in any other way.
The exhibitor is liable for damage caused during the rental period and will be charged with the costs.

The charges for additional equipment are invoiced by the ServicePartner.

Remarks: _____



Orders received later than 14 days before the start of the event will be billed an express surcharge of 25 %, subject to a minimum surcharge of EUR 10 per order. With our authorized signature below, we acknowledge acceptance of all items of the General and Special Terms of Business of NürnbergMesse and the General Terms of Business and the Special Conditions for Services of the ServicePartner.

Place and date _____

Company stamp and authorized signature _____

Nuremberg, Germany
14-16.3.2017



embeddedworld2017

Exhibition & Conference
... it's a smarter world

Return to
NürnbergMesse GmbH
MesseService
Messezentrum
90471 Nürnberg
Tel +49 (0) 9 11. 86 06-80 00
Fax +49 (0) 9 11. 86 06-80 01
messeservice@nuernbergmesse.de

Contractor *
Messebau Wörnlein GmbH
Messezentrum
90471 Nürnberg
Tel +49 (0) 9 11. 81 74 49-0
Fax +49 (0) 9 11. 81 74 49-25
info@woernlein.de
www.woernlein.de

Company _____

Street _____

Postcode, Town, Country _____

Tel _____

Fax _____

E-mail _____

Return deadline
14.12.2016

Hall/Stand

Person to contact _____

Tel _____

Fax _____

Invoice address (only if different) _____

Order

Stand type (Please enclose plan):



in-line stand



corner stand



head stand



block stand

Stand size: front _____ m x depth _____ m **minimum size: 9 m²**

The rental for the duration of the event includes the following equipment:

Walls

white plastic-coated stand partition walls on all closed sides of the stand space (Syma system; 2.50 m high)

Needle-felt carpet

including dust sheet, edging tape and disposal needle felt, anthracite or:
 blue gray red
 green beige

Cubicle

size according to stand space; with **curtain in gray or:**
 blue black red
 green
 or 1 lockable hinged door at extra cost: EUR 47.90

Graphic elements

colored panel on Axiom wall; (RAL colors: blue 5017; red 3020; gray 7012; green 6029)

Shapes triangular or:

without graphic elements
 strip

To see the shapes, please have a look at the backside

colored plastic in gray or:

red blue black

Quadrate columns

at all open corners of stand space of corner, head and block stands (RAL colors as above) anodized **in gray or:**
 blue red green
 white

NEW! Lattice support (System Syma) with fascia

on all open sides of the stand space; (RAL colors see graphic elements)

Slide-in fascia 2.00 x 0.295 m or:

rectangular 1.50 m x 0.75 m
 oval 1.50 m x 0.70 m
colored plastic **in white or:**
 blue gray red
 green

Lettering

on fascia; brief company name and place of business in Helvetica medium, black lettering with white fascia and white lettering with all other colors. Please enter text in "Remarks" box on the right, see overleaf for surcharge for company logo.

1 white table round

diameter 0.70 m or:
 square 0.70 x 0.70 m

3 upholstered chairs

"Opus" black

1 counter

1.00 x 0.50 x 1.00 m; white; not lockable; 1 shelf
 at extra cost EUR 75.40

1 coat rack with 5 hooks

at extra cost EUR 18.50

1 waste paper basket

at extra cost EUR 8.70

NEW! 1 halogen spotlight

100 W, per full 4 m² of stand space, mounted on power rails; silver

Continued overleaf!

Orders received later than 14 days before the start of the event will be billed an express surcharge of 25 %, subject to a minimum surcharge of EUR 10 per order.

Yes, we order daily cleaning during the exhibition at a total extra price of EUR 1.65/m².

All prices stated are subject to the addition of **VAT at the statutory rate** and 3 % **insurance premium**.

* If necessary, NürnbergMesse is entitled to have the service ordered provided by another ServicePartner. In this case, the customer will be notified of the other ServicePartner in good time.

With our authorized signature below, we acknowledge acceptance of all items of the General and Special Terms of Business of NürnbergMesse and the General Terms of Business and the Special Conditions for Services of the ServicePartner.

We do not require insurance and accept liability for the stand and rented objects.

VAT ID number of exhibitor:

<input type="text"/>	<input type="text"/>	<input type="text"/>	<input type="text"/>	<input type="text"/>	<input type="text"/>	<input type="text"/>	<input type="text"/>	<input type="text"/>	<input type="text"/>	<input type="text"/>	<input type="text"/>	<input type="text"/>	<input type="text"/>	<input type="text"/>	<input type="text"/>	<input type="text"/>	<input type="text"/>	<input type="text"/>	<input type="text"/>
----------------------	----------------------	----------------------	----------------------	----------------------	----------------------	----------------------	----------------------	----------------------	----------------------	----------------------	----------------------	----------------------	----------------------	----------------------	----------------------	----------------------	----------------------	----------------------	----------------------



Complete price EUR 86.90/m²

incl. power supply rated at 3 kW, consumption and pre-show cleaning

You can use our practical online aid on the Internet at www.standconfigurator.com to visualize the shape, color and equipment of **your** personal exhibition stand. We will be pleased to advise you personally:

Tel +49 (0) 9 11. 86 06-80 00 or
messeservice@nuernbergmesse.de

Additional services, special equipment and individual requirements are obtainable on request and can be ordered overleaf.

Text for lettering on fascia:

<input type="text"/>	<input type="text"/>	<input type="text"/>	<input type="text"/>	<input type="text"/>	<input type="text"/>	<input type="text"/>	<input type="text"/>	<input type="text"/>	<input type="text"/>	<input type="text"/>	<input type="text"/>	<input type="text"/>	<input type="text"/>	<input type="text"/>	<input type="text"/>	<input type="text"/>	<input type="text"/>	<input type="text"/>	<input type="text"/>
----------------------	----------------------	----------------------	----------------------	----------------------	----------------------	----------------------	----------------------	----------------------	----------------------	----------------------	----------------------	----------------------	----------------------	----------------------	----------------------	----------------------	----------------------	----------------------	----------------------

<input type="text"/>	<input type="text"/>	<input type="text"/>	<input type="text"/>	<input type="text"/>	<input type="text"/>	<input type="text"/>	<input type="text"/>	<input type="text"/>	<input type="text"/>	<input type="text"/>	<input type="text"/>	<input type="text"/>	<input type="text"/>	<input type="text"/>	<input type="text"/>	<input type="text"/>	<input type="text"/>	<input type="text"/>	<input type="text"/>
----------------------	----------------------	----------------------	----------------------	----------------------	----------------------	----------------------	----------------------	----------------------	----------------------	----------------------	----------------------	----------------------	----------------------	----------------------	----------------------	----------------------	----------------------	----------------------	----------------------

Place and date _____

Company stamp and authorized signature _____

Order (continued)

Power supply

in the cubicle, rated at 3 kW (AC), including consumption and 3-way mains socket.

- Power rating increased from 3 kW to 6 kW (AC) surcharge EUR 167.50
- Power rating increased from 3 kW to 9 kW surcharge EUR 237.00

Power supply of more than 9 kW
– see Online ExhibitorShop under **Technical Services – Electricity supply**. (PDF Form S2.10)

NEW! Including pre-show cleaning before the start of the exhibition, removing and disposal of carpet dust sheet.

Shapes of graphic elements

Triangular

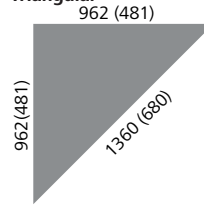

Strip

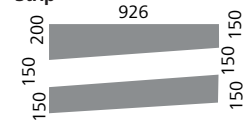

Merasurement in mm

Size rules for cubicles:

- up to 24 m² = 1 m²
- up to 32 m² = 2 m²
- up to 40 m² = 3 m²
- more than 40 m² = 4 m²

Additional equipment
Complete rental stand MERCURY

Order

1. Exclusive variations

1.1 Floor covering (per m²):

Ribbed

including dust sheet, edging tape and disposal

- silver EUR 1.60
- red EUR 1.60
- anthracite EUR 1.60
- blue EUR 1.60

Velour

including dust sheet, edging tape and disposal

- silver EUR 6.70
- anthracite EUR 6.70

1.2 Larger cubicle (per m²):

- additional space EUR 14.90

1.3 Graphic elements (each):

Graphic element (in any color)

- EUR 24.50

1.4 Counter lockable

1 Counter System Syma, lockable
0.98 x 0.50 x 1.12 m; white, with one shelf

- at extra cost EUR 96.90

2. Additional stand equipment

2.1 Additional furniture (each):

Table white

- square 0.70 x 0.70 m EUR 27.00
- round ø 0.70 m EUR 27.00

Chair

- "Opus" black EUR 19.70

2.2 Additional spotlights (each):

- 100 W Halogenspotlight EUR 39.20

2.3 Light column (each)

2.50 m high, segment-shaped curved acryl glass, back-lit, approx. 1.00 m wide, free-standing arrangement possible (including safety socket).

- without digital printing EUR 288.50
- with digital printing on one side EUR 445.50
- with digital printing on both sides EUR 599.50

Print data are provided by the customer in each case.

3. Logo (digital print) surcharge per logo:

- Slide-in fascia (2.00 x 0.295 m)
 - EUR 56.50
- Rectangular fascia (1.50 x 0.75 m)
 - EUR 70.10
- Oval fascia (1.50 x 0.70 m)
 - EUR 75.80

Data formats: printable PDF files; also EPS (vector format, fonts converted into paths).

Print lead time: 4 weeks prior to start of exhibition.

In the case of data that cannot be printed directly, processing fees of EUR 83.80/hour apply.

See Online ExhibitorShop / Stand Construction – Lettering/Prints – Fascia Lettering (contractor: Messebau Wörnlein GmbH). (PDF Form S1.71)

Floral stand decoration – see Online ExhibitorShop under **Stand Construction – Floral stand decoration / landscaping services**.

Exclusive and additional equipment can be seen in the stand configurator at **www.standconfigurator.com**.

More stand equipment components – see Online ExhibitorShop under **Stand Construction – Extra stand equipment / floor coverings / furniture – Stand equipment** (contractor: Messebau Wörnlein GmbH). (PDF Forms S1.64 – 1.66)

All prices

are subject to the addition of VAT at the statutory rate and 3 % insurance premium for stand material and furniture.

- We do not require insurance and accept liability for damage and loss.

Services on request

The following hourly flat rates are charged plus VAT at the statutory rate:

1. Installation hour at EUR 43.40
2. Workshop hour at EUR 41.80
3. Machine hour at EUR 61.70

The organizer is responsible for assembling and dismantling the MERCURY complete rental stand.

The complete rental stand and its equipment must not be pasted over, nailed, painted or damaged in any other way.

The exhibitor is liable for damage caused during the rental period and will be charged with the costs.

The charges for additional equipment are invoiced by the ServicePartner.

Remarks: _____

Design examples with articles at extra cost:



Orders received later than 14 days before the start of the event will be billed an express surcharge of 25 %, subject to a minimum surcharge of EUR 10 per order. With our authorized signature below, we acknowledge acceptance of all items of the General and Special Terms of Business of NürnbergMesse and the General Terms of Business and the Special Conditions for Services of the ServicePartner.

Complete rental stand EARTH

S0.30

Nuremberg, Germany
14-16.3.2017



embeddedworld2017

Exhibition & Conference

... it's a smarter world

Return to
NürnbergMesse GmbH
MesseService
Messezentrum
90471 Nürnberg
Tel +49 (0) 9 11. 86 06-80 00
Fax +49 (0) 9 11. 86 06-80 01
messeservice@nuernbergmesse.de

Contractor *
:mesomondo GmbH
Messezentrum 1
90471 Nürnberg
Tel +49 (0) 9 11. 40 08 35-0
Fax +49 (0) 9 11. 40 08 35-29
info@mesomondo.de
www.mesomondo.de

Return deadline
14.12.2016

Hall/Stand

Company _____

Street _____

Postcode, Town, Country _____

Tel _____

Fax _____

E-mail _____

Person to contact _____

Tel _____

Fax _____

Invoice address (only if different) _____

Order

Stand type (Please enclose plan):



in-line stand



corner stand



head stand



block stand

Stand size: front _____ m x depth _____ m **minimum size: 9 m²**

The rental for the duration of the event includes the following equipment:

Walls

white plastic-coated stand partition walls on all closed sides of the stand space (Syma system; 2.50 m high)

Dolphin fascia shape or:

slide-in fascia

White or:

red

blue

gray

green

yellow

Ribbed carpet

including dust sheet, edging tape and disposal, anthracite or:

red blue light gray

Cubicle

size according to stand space; with curtain in white or:

1 lockable hinged door at extra cost **EUR 47.90**

Decorative element

colored, plastic-coated; on all open sides of stand space; (RAL colors: red 3020; gray 7037; yellow 1023; blue 5017; green 6029) rectangular Shape or:

half-round

blue colored or:

red gray green yellow

Corner column

shape to match decorative element; round or square; in same color as decorative element

Lattice support

height of top 2.80 m; aluminum color; with slide-in fascia or fascia panel, on all open sides of stand space; (RAL colors as above) with

Lettering

on fascia; brief company name and place of business in Helvetica medium white or black (in combination with white or yellow fascia)

Please enter text in "Remarks" box on the right, see overleaf for surcharge for company logo.

1 table

chrome frame with white top 0.70 x 0.70 m

4 black upholstered chairs "Bonni" or:

anthracite

1 counter

0.92 x 0.52 x 1.05 m; white; lockable

at extra cost **EUR 75.40**

1 coat rack at extra cost **EUR 19.90**

1 waste paper basket at extra cost **EUR 8.70**

1 extending spotlight

130 W for each full 3 m² of stand space

Continued overleaf!

VAT ID number of exhibitor:

<input type="text"/>	<input type="text"/>	<input type="text"/>	<input type="text"/>	<input type="text"/>	<input type="text"/>	<input type="text"/>	<input type="text"/>	<input type="text"/>	<input type="text"/>	<input type="text"/>	<input type="text"/>	<input type="text"/>	<input type="text"/>	<input type="text"/>	<input type="text"/>	<input type="text"/>	<input type="text"/>	<input type="text"/>	<input type="text"/>
----------------------	----------------------	----------------------	----------------------	----------------------	----------------------	----------------------	----------------------	----------------------	----------------------	----------------------	----------------------	----------------------	----------------------	----------------------	----------------------	----------------------	----------------------	----------------------	----------------------



Complete price EUR 107.50/m²
incl. power supply rated at 3 kW, consumption and pre-show cleaning

You can use our practical online aid on the Internet at www.standconfigurator.com to visualize the shape, color and equipment of your personal exhibition stand. We will be pleased to advise you personally:

Tel +49 (0) 9 11. 86 06-80 00 or
messeservice@nuernbergmesse.de

Additional services, special equipment and individual requirements are obtainable on request and can be ordered overleaf.

Text for lettering on fascia:

<input type="text"/>	<input type="text"/>	<input type="text"/>	<input type="text"/>	<input type="text"/>	<input type="text"/>	<input type="text"/>	<input type="text"/>	<input type="text"/>	<input type="text"/>	<input type="text"/>	<input type="text"/>	<input type="text"/>	<input type="text"/>	<input type="text"/>	<input type="text"/>	<input type="text"/>	<input type="text"/>	<input type="text"/>	<input type="text"/>
<input type="text"/>	<input type="text"/>	<input type="text"/>	<input type="text"/>	<input type="text"/>	<input type="text"/>	<input type="text"/>	<input type="text"/>	<input type="text"/>	<input type="text"/>	<input type="text"/>	<input type="text"/>	<input type="text"/>	<input type="text"/>	<input type="text"/>	<input type="text"/>	<input type="text"/>	<input type="text"/>	<input type="text"/>	<input type="text"/>

Orders received later than 14 days before the start of the event will be billed an express surcharge of 25 %, subject to a minimum surcharge of EUR 10 per order.

Yes, we order daily cleaning during the exhibition at a total extra price of EUR 1.65/m².

All prices stated are subject to the addition of **VAT at the statutory rate** and **3 % insurance premium**.

* If necessary, NürnbergMesse is entitled to have the service ordered provided by another ServicePartner. In this case, the customer will be notified of the other ServicePartner in good time.

With our authorized signature below, we acknowledge acceptance of all items of the General and Special Terms of Business of NürnbergMesse and the General Terms of Business and the Special Conditions for Services of the ServicePartner.

We do not require insurance and accept liability for the stand and rented objects.

Place and date _____

Company stamp and authorized signature _____

Order (continued)

Power supply

in the cubicle, rated at 3 kW (AC), including consumption and 3-way mains socket.

- Power rating increased from 3 kW to 6 kW (AC) surcharge EUR 167.50
- Power rating increased from 3 kW to 9 kW surcharge EUR 237.00

Power supply of more than 9 kW – see Online ExhibitorShop under Technical Services – Electricity supply. (PDF Form S2.10)

NEW! Including pre-show cleaning

before the start of the exhibition, including removing and disposal of carpet dust sheet.

Additional equipment
Complete rental stand EARTH

Order

1. Exclusive variations

1.1 Floor covering (surcharge per m²):

Laminate

with false floor (63 mm); suitable for laying cables below; aluminum edging strip

- Polar oak longstrip wood floor EUR 30.60
- Maple plank longstrip wood floor EUR 30.60
- Walnut patchwood longstrip wood floor EUR 30.60
- Oak Cappuccino 1-strip flooring EUR 30.60
- Canadian spruce 2-strip plank flooring EUR 30.60

False floor

63 mm chipboard; suitable for laying cables below; aluminum edging strip

- EUR 14.45

1.2 Larger cubicle (per m²):

- additional space EUR 41.60

1.3 Wall cladding (per m)

without visible supports, height 2.50 m (surcharge). These walls are just asking to be used for graphics.

- EUR 32.00

3. Logo/graphics (surcharge per logo):

3.1 Graphics at the wall (per m²)

digital printing, mounted professionally at the wall

- EUR 62.00

3.2 Logo as digital print at fascia

- Slide-in fascia (per m) EUR 20.50
- Dolphin fascia (per pc.) EUR 65.10

The data for logos and printing – as vectorized file (.eps or .ai) with 300 dpi in 1:10 format – must be received by not later than 20 days before the event!

Floral stand decoration – see Online ExhibitorShop under Stand Construction – Floral stand decoration / landscaping services.

Exclusive and additional equipment can be seen in the stand configurator at www.standconfigurator.com. Additional stand equipment can be found at www.mesomondo.de.

All prices

are subject to the addition of VAT at the statutory rate and 3 % insurance premium for stand material and furniture.

- We do not require insurance and accept liability for damage and loss.

Services on request

The following hourly flat rates are charged plus VAT at the statutory rate:

- 1. Working hour at EUR 49.50

The organizer is responsible for assembling and dismantling the EARTH complete rental stand.

The complete rental stand and its equipment must not be pasted over, nailed, painted or damaged in any other way.

The exhibitor is liable for damage caused during the rental period and will be charged with the costs.

The charges for additional equipment are invoiced by the ServicePartner.

Remarks: _____

2. Additional stand equipment

2.1 Product display units (each):

Dialog shelf unit

2.50 x 0.96 m; silver; 5 shelves

- EUR 122.80

Showcase in design element

Inside height 0.59 m; not illuminated or lockable

- EUR 167.20

2.2 Additional furniture (each):

Table

- 0.70 x 0.70 m EUR 28.00

Upholstered chair "Bonni"

- black EUR 21.50
- anthracite EUR 21.50

2.3 Additional spotlights (each):

- 130 W, energy saver EUR 39.00



Orders received later than 14 days before the start of the event will be billed an express surcharge of 25 %, subject to a minimum surcharge of EUR 10 per order.

With our authorized signature below, we acknowledge acceptance of all items of the General and Special Terms of Business of NürnbergMesse and the General Terms of Business and the Special Conditions for Services of the ServicePartner.

Place and date _____

Company stamp and authorized signature _____

Complete rental stand MOON

S0.31

Nuremberg, Germany
14–16.3.2017



embeddedworld2017

Exhibition & Conference
... it's a smarter world

Return to
NürnbergMesse GmbH
MesseService
Messezentrum
90471 Nürnberg
Tel +49 (0) 9 11. 86 06-80 00
Fax +49 (0) 9 11. 86 06-80 01
messeservice@nuernbergmesse.de

Contractor *
Messebau Wörnlein GmbH
Messezentrum
90471 Nürnberg
Tel +49 (0) 9 11. 81 74 49-0
Fax +49 (0) 9 11. 81 74 49-25
info@woernlein.de
www.woernlein.de

Company

Street

Postcode, Town, Country

Tel

Fax

E-mail

Return deadline
14.12.2016

Hall/Stand

Person to contact

Tel

Fax

Invoice address (only if different)

Order

Stand type (Please enclose plan):



in-line stand



corner stand



head stand



block stand

Stand size: front _____ m x depth _____ m **minimum size: 9 m²**

The rental for the duration of the event includes the following equipment:

Walls

plastic-coated stand partition walls, white, on all closed sides of the stand space

NEW! (Syma system; 2.50 m high)

Carpets, ripped,

including dust sheet, edging tape and disposal

in anthracite or:

silver blue red

needle felt:

blue gray anthracite
 red green beige

Cubicle

size according to stand space; in same color as wall **with curtain in gray or:**

blue red black
 or 1 lockable hinged door
at extra cost : EUR 47.90

Column element

3 m high; 0.70 m wide; triangular column element in same color as wall on all open stand sides; each with 2 DIN A4 leaflet holders

Graphic element

graphic triangles on each column element; **element in gray or:**

blue red green
(RAL colors: blue 5017; red 3020; gray 7012; green 6029)

NEW! Columns (Syma system) at all open corners of head and block stands;

anodized **in gray or:**

blue red green
 white

Lattice support

with fascia panel on all open sides of the stand space; (see graphic element for RAL colors);

dolphin fascia 1.50 x 0.835 m or:

oval fascia 1.50 x 0.70 m colored plastic, **white or:**
 blue red gray
 green

Lettering

on fascia; brief company name and place of business in Helvetica medium **black or:**

blue gray red
 green white

Please enter text in "Remarks" box on the right, see overleaf for surcharge for company logo.

1 white table

square 0.70 x 0.70 m; chrome frame

4 upholstered chairs "Opus" black or:

"Classic" anthracite
 "Classic" blue

1 counter

1.00 x 0.50 x 1.00 m; white; not lockable; 1 shelf;

at extra cost EUR 75.40

Continued overleaf!

Orders received later than 14 days before the start of the event will be billed an express surcharge of 25 %, subject to a minimum surcharge of EUR 10 per order.

Yes, we order daily cleaning during the exhibition at a total extra price of EUR 1.65/m².

All prices stated are subject to the addition of VAT at the statutory rate and 3 % insurance premium.

* If necessary, NürnbergMesse is entitled to have the service ordered provided by another ServicePartner. In this case, the customer will be notified of the other ServicePartner in good time.

With our authorized signature below, we acknowledge acceptance of all items of the General and Special Terms of Business of NürnbergMesse and the General Terms of Business and the Special Conditions for Services of the ServicePartner.

We do not require insurance and accept liability for the stand and rented objects.

VAT ID number of exhibitor:

<input type="text"/>	<input type="text"/>	<input type="text"/>	<input type="text"/>	<input type="text"/>	<input type="text"/>	<input type="text"/>	<input type="text"/>	<input type="text"/>	<input type="text"/>	<input type="text"/>	<input type="text"/>	<input type="text"/>	<input type="text"/>	<input type="text"/>	<input type="text"/>	<input type="text"/>	<input type="text"/>	<input type="text"/>	<input type="text"/>
----------------------	----------------------	----------------------	----------------------	----------------------	----------------------	----------------------	----------------------	----------------------	----------------------	----------------------	----------------------	----------------------	----------------------	----------------------	----------------------	----------------------	----------------------	----------------------	----------------------



Complete price EUR 107.50/m²
incl. power supply rated at 3 kW, consumption and pre-show cleaning

You can use our practical online aid on the Internet at www.standconfigurator.com to visualize the shape, color and equipment of **your** personal exhibition stand. We will be pleased to advise you personally:

Tel +49 (0) 9 11. 86 06-80 00 or
messeservice@nuernbergmesse.de

Additional services, special equipment and individual requirements are obtainable on request and can be ordered overleaf.

Text for lettering on fascia:

<input type="text"/>	<input type="text"/>	<input type="text"/>	<input type="text"/>	<input type="text"/>	<input type="text"/>	<input type="text"/>	<input type="text"/>	<input type="text"/>	<input type="text"/>	<input type="text"/>	<input type="text"/>	<input type="text"/>	<input type="text"/>	<input type="text"/>	<input type="text"/>	<input type="text"/>	<input type="text"/>	<input type="text"/>	<input type="text"/>
----------------------	----------------------	----------------------	----------------------	----------------------	----------------------	----------------------	----------------------	----------------------	----------------------	----------------------	----------------------	----------------------	----------------------	----------------------	----------------------	----------------------	----------------------	----------------------	----------------------

<input type="text"/>	<input type="text"/>	<input type="text"/>	<input type="text"/>	<input type="text"/>	<input type="text"/>	<input type="text"/>	<input type="text"/>	<input type="text"/>	<input type="text"/>	<input type="text"/>	<input type="text"/>	<input type="text"/>	<input type="text"/>	<input type="text"/>	<input type="text"/>	<input type="text"/>	<input type="text"/>	<input type="text"/>	<input type="text"/>
----------------------	----------------------	----------------------	----------------------	----------------------	----------------------	----------------------	----------------------	----------------------	----------------------	----------------------	----------------------	----------------------	----------------------	----------------------	----------------------	----------------------	----------------------	----------------------	----------------------

Place and date

Company stamp and authorized signature

Order (continued)

- 1 coat rack** with 5 hooks
 at extra cost EUR 18.50
- 1 waste paper basket**
 at extra cost EUR 8.70
- 1 halogen spotlight "Collus"**
130 W, energy saver,
per full 3 m² of stand space;
individually adjustable
- NEW! Including pre-show cleaning**
before the start of the exhibition,
removing and disposal of carpet dust
sheet.

- Power supply**
in the cubicle, rated at 3 kW (AC),
including consumption and 3-way
mains socket.
 Power rating increased from 3 kW
to 6 kW (AC) surcharge EUR 167.50
 Power rating increased from 3 kW
to 9 kW surcharge EUR 237.00
- Power supply of more than 9 kW**
– see [Online ExhibitorShop](#) under
Technical Services – Electricity
supply. (PDF Form S2.10)

Shapes of graphic element:

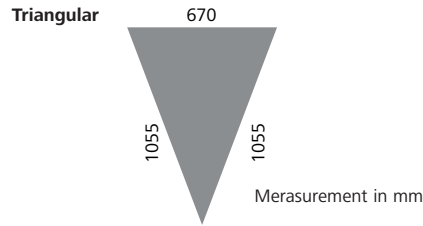

Size rules for cubicles:

- up to 32 m² = 2 m²
- up to 40 m² = 3 m²
- more than 40 m² = 4 m²

Additional equipment
Complete rental stand MOON

Order

- 1. Exclusive variations**
- 1.1 Floor covering (per m²):**
 - Velour**
including dust sheet, edging tape
and disposal
 silver EUR 6.70
 anthracite EUR 6.70
 - False floor**
22 mm chipboard; suitable
for laying cables; aluminum
edging strip
 EUR 23.20
 - Laminate**
with false floor 22 mm and
aluminum
edging strip
 beech EUR 37.40
 maple EUR 37.40
 cherry EUR 37.40
 - white
 matt EUR 61.10
 gloss EUR 61.10
- 1.2 Larger cubicle (per m²):**
 additional space EUR 14.90

- 1 Counter System Syma, lockable**
0.98 x 0.50 x 1.12 m; white,
with one shelf
 at extra cost EUR 96.90
- 2.3 Additional spotlights (each):**
 "Collus", 130 W EUR 39.00
- 2.4 Light column (each)**
4.00 m high, segment-shaped
curved acryl glass, back-lit, approx.
1.00 m wide, free-standing arrange-
ment possible (including safety
socket).
 without digital printing
EUR 427.50
 with digital printing
on one side EUR 654.50
 with digital printing
on both sides EUR 884.50
Print data are provided by the
customer in each case.
- 3. Logo (digital print)**
surcharge per logo:
Dolphin fascia (1.50 x 0.835 m)
 EUR 70.10
Oval fascia (1.50 x 1.70 m)
 EUR 75.80

Exclusive and additional equipment
can be seen in the stand configurator at
www.standconfigurator.com.
More stand equipment components –
see [Online ExhibitorShop](#) under **Stand**
Construction – Extra stand equipment /
floor coverings / furniture – Stand equip-
ment (contractor: Messebau Wörnlein
GmbH). (PDF Forms S1.64 – 1.66)

All prices
are subject to the addition of VAT
at the statutory rate and 3 % insurance
premium for stand material and
furniture.

We do not require insurance and
accept liability for damage and loss.

Services on request
The following hourly flat rates are
charged plus VAT at the statutory rate:

- 1. Installation hour at EUR 43.40
- 2. Workshop hour at EUR 41.80
- 3. Machine hour at EUR 61.70

The organizer is responsible for
assembling and dismantling the MOON
complete rental stand.

The complete rental stand and its
equipment must not be pasted over,
nailed, painted or damaged in any
other way.

The exhibitor is liable for damage
caused during the rental period and
will be charged with the costs.

The charges for additional equipment are invoiced by the ServicePartner.

Remarks: _____

- 2. Additional stand equipment**
- 2.1 Product display units in column element (each):**
 - Showcase**
0.35 x 0.35 x 0.50 m;
lockable display area; triangular;
with built-in spotlight
 EUR 219.50
 - Open showcase**
0.35 x 0.35 m; open display area;
triangular; with built-in spotlight
 EUR 172.50
- 2.2 Additional furniture (each):**
 - Table**
chrome frame with white top;
square 0.70 x 0.70 m
 EUR 27.00
 - Upholstered chair**
 "Classic" anthracite EUR 18.00
 "Classic" blue EUR 18.00
 "Opus" black EUR 19.70

Data formats: printable PDF files;
also EPS (vector format, fonts
converted into paths).
Print lead time: 4 weeks prior to
start of exhibition.
In the case of data that cannot be
printed directly, processing fees of
EUR 83.80/hour apply.

See [Online ExhibitorShop / Stand](#)
Construction – Lettering/Prints –
Fascia Lettering (contractor:
Messebau Wörnlein GmbH).
(PDF Form S1.71)

Floral stand decoration – see Online
ExhibitorShop under Stand
Construction – Floral stand
decoration / landscaping services.

Design examples with articles at extra cost:

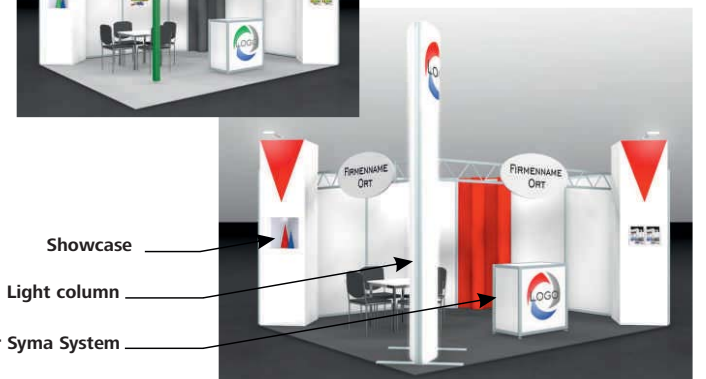

Orders received later than 14 days before the start of the event will be billed an express surcharge of 25 %, subject to a minimum surcharge of EUR 10 per order.
With our authorized signature below, we acknowledge acceptance of all items of the General and Special Terms of Business of NürnbergMesse and the General Terms of Business and the Special Conditions for Services of the ServicePartner.

Complete rental stand APOLLO

S0.40

Nuremberg, Germany
14-16.3.2017



embeddedworld2017

Exhibition & Conference
... it's a smarter world

Return to
NürnbergMesse GmbH
MesseService
Messezentrum
90471 Nürnberg
Tel +49 (0) 9 11. 86 06-80 00
Fax +49 (0) 9 11. 86 06-80 01
messeservice@nuernbergmesse.de

Contractor *
:mesomondo GmbH
Messezentrum 1
90471 Nürnberg
Tel +49 (0) 9 11. 40 08 35-0
Fax +49 (0) 9 11. 40 08 35-29
info@mesomondo.de
www.mesomondo.de

Return deadline
14.12.2016

Hall/Stand

Company

Street

Postcode, Town, Country

Tel

Fax

E-mail

Person to contact

Tel

Fax

Invoice address (only if different)

Order

Stand type (Please enclose plan):



in-line stand



corner stand



head stand



block stand

Stand size: front _____ m x depth _____ m **minimum size: 20 m²**

The rental for the duration of the event includes the following equipment:

Wall construction

Conventional wall construction, white, (no system material visible), height 3.50 m, on all closed sides of the stand space

Floor

Velour carpet, brand new, including edge band, carpet disposal and protective sheet in anthracite or:
 light gray

Cubicle

1.00 m², lockable with hinged door, height 2.50 m, side walls of conventional wall construction, white (no system material visible)

Tower for distant advertising effect (construction SYMA-MOLTO 90), with sign panels and fabric banner

Height 4.50 m, for incorporation of lighting and graphic elements,
- including white graphic panels, lettering as 1 color-plot or single-colour logo (in-line stand 1 panel, corner stands 2 panels, head or block stands 3 panels)
- including a digitally printed fabric banner between the supports at the rear wall (1.80 x 3.195 m), exhibitor must provide printing data 20 days before the event

Seating group

1 table

0.70 x 0.70 m; chrome frame with white top

4 "Catifa" chairs

white, with chrome frame

or in exchange for seating group

at extra cost EUR 20.40
1 high table and 2 "Z" bar stools

1 counter

0.92 x 0.52 x 1.05 m; white; lockable

at extra cost EUR 75.40

1 coat rack at extra cost EUR 19.90

1 waste paper basket at extra cost EUR 8.70

Lightning

1 HQI spotlight, 150 W for each full 5 m² of stand space

Power supply

in the cubicle, rated at 3 kW (AC), including consumption and 3-way mains socket.

Power rating increased from 3 kW to 6 kW (AC) surcharge EUR 167.50

Power rating increased from 3 kW to 9 kW surcharge EUR 237.00

Power supply of more than 9 kW

- see **Online ExhibitorShop under Technical Services - Electricity supply. (PDF Form S2.10)**

NEW! Including pre-show cleaning

before the start of the exhibition, including removing and disposal of carpet dust sheet.

VAT ID number of exhibitor:

<input type="text"/>	<input type="text"/>	<input type="text"/>	<input type="text"/>	<input type="text"/>	<input type="text"/>	<input type="text"/>	<input type="text"/>	<input type="text"/>	<input type="text"/>	<input type="text"/>	<input type="text"/>	<input type="text"/>	<input type="text"/>	<input type="text"/>	<input type="text"/>	<input type="text"/>	<input type="text"/>	<input type="text"/>	<input type="text"/>
----------------------	----------------------	----------------------	----------------------	----------------------	----------------------	----------------------	----------------------	----------------------	----------------------	----------------------	----------------------	----------------------	----------------------	----------------------	----------------------	----------------------	----------------------	----------------------	----------------------



APOLLO

Complete price EUR 138.90/m²
incl. power supply rated at 3 kW, consumption and pre-show cleaning

You can use our practical online aid on the Internet at www.standconfigurator.com to visualize the shape, color and equipment of **your** personal exhibition stand. We will be pleased to advise you personally:

Tel +49 (0) 9 11. 86 06-80 00 or
messeservice@nuernbergmesse.de

Additional services, special equipment and individual requirements are obtainable on request and can be ordered overleaf.

Text for lettering on fascia:

<input type="text"/>	<input type="text"/>	<input type="text"/>	<input type="text"/>	<input type="text"/>	<input type="text"/>	<input type="text"/>	<input type="text"/>	<input type="text"/>	<input type="text"/>	<input type="text"/>	<input type="text"/>	<input type="text"/>	<input type="text"/>	<input type="text"/>	<input type="text"/>	<input type="text"/>	<input type="text"/>	<input type="text"/>	<input type="text"/>
----------------------	----------------------	----------------------	----------------------	----------------------	----------------------	----------------------	----------------------	----------------------	----------------------	----------------------	----------------------	----------------------	----------------------	----------------------	----------------------	----------------------	----------------------	----------------------	----------------------

<input type="text"/>	<input type="text"/>	<input type="text"/>	<input type="text"/>	<input type="text"/>	<input type="text"/>	<input type="text"/>	<input type="text"/>	<input type="text"/>	<input type="text"/>	<input type="text"/>	<input type="text"/>	<input type="text"/>	<input type="text"/>	<input type="text"/>	<input type="text"/>	<input type="text"/>	<input type="text"/>	<input type="text"/>	<input type="text"/>
----------------------	----------------------	----------------------	----------------------	----------------------	----------------------	----------------------	----------------------	----------------------	----------------------	----------------------	----------------------	----------------------	----------------------	----------------------	----------------------	----------------------	----------------------	----------------------	----------------------

Orders received later than 14 days before the start of the event will be billed an express surcharge of 25 %, subject to a minimum surcharge of EUR 10 per order.

Yes, we order daily cleaning during the exhibition at a total extra price of EUR 1.65/m².

All prices stated are subject to the addition of **VAT at the statutory rate** and **3 % insurance premium**.

* If necessary, NürnbergMesse is entitled to have the service ordered provided by another ServicePartner. In this case, the customer will be notified of the other ServicePartner in good time.

With our authorized signature below, we acknowledge acceptance of all items of the General and Special Terms of Business of NürnbergMesse and the General Terms of Business and the Special Conditions for Services of the ServicePartner.

We do not require insurance and accept liability for the stand and rented objects.

Place and date

Company stamp and authorized signature

Additional equipment Complete rental stand APOLLO

Order

1. Exclusive variations

1.1 Walls:

Wall cladding (per m)

EUR 76.50

Mounting wall for monitors, shelves ... (may be damaged, price per linear m)

EUR 103.00

Wall shelf, white, 1.00 x 0.26 cm

EUR 20.40

1.2 Flooring (per m²):

Laminate

with false floor, chipboard, 63 mm, cable installation possible, including aluminum edge

Polar oak longstrip wood floor EUR 30.60

Maple plank longstrip wood floor EUR 30.60

Walnut patchwood longstrip wood floor EUR 30.60

Oak Cappuccino 1-strip flooring EUR 30.60

Canadian spruce 2-strip plank flooring EUR 30.60

False floor

Chipboard 63 mm; suitable for laying cables below; including aluminum edge

EUR 14.45

1.3 Tower for distant advertising effect

Extra tower (starting from 10.00 m width recommended)

EUR 969.00

Extra banner including digital print

Between the tower supports at the rear wall (1.80 x 3.195 m), exhibitor must provide printing data 20 days before the event

EUR 257.00

2. Stand-specific additional equipment (per unit)

2.1 Extra furniture (per unit):

Table as above EUR 28.00

Chair as above EUR 35.70

2.2 Extra spotlight (per unit)

HQI 150 watts EUR 93.30

2.3. Monitor incl. mounting on mounting wall and extra safety socket

LCD monitor 40", including playback device, and mounting

EUR 438.60

3. Logo (surcharge per unit):

Logo as digital print on the graphic panel in the tower

EUR 63.30

The data for logos and printing – as vectorized file (.eps or .ai) with 300 dpi in 1:10 format – must be received by not later than 20 days before the event!

Floral stand decoration – see Online ExhibitorShop under Stand Construction – Floral stand decoration / landscaping services.

Exclusive and additional equipment can be seen in the stand configurator at **www.standconfigurator.com.**

Additional stand equipment can be found at **www.mesomondo.de.**

All prices

are subject to the addition of VAT at the statutory rate and 3 % insurance premium for stand material and furniture.

We do not require insurance and accept liability for damage and loss.

Services on request

The following hourly flat rates are charged plus VAT at the statutory rate:

The charges for additional equipment are invoiced by the ServicePartner.

Remarks: _____



Orders received later than 14 days before the start of the event will be billed an express surcharge of 25 %, subject to a minimum surcharge of EUR 10 per order.

With our authorized signature below, we acknowledge acceptance of all items of the General and Special Terms of Business of NürnbergMesse and the General Terms of Business and the Special Conditions for Services of the ServicePartner.

Place and date _____

Company stamp and authorized signature _____

Nuremberg, Germany
14-16.3.2017



embeddedworld2017

Exhibition & Conference
... it's a smarter world

Return to
NürnbergMesse GmbH
MesseService
Messezentrum
90471 Nürnberg
Tel +49 (0) 9 11. 86 06-80 00
Fax +49 (0) 9 11. 86 06-80 01
messeservice@nuernbergmesse.de

Contractor *
Messebau Wörnlein GmbH
Messezentrum
90471 Nürnberg
Tel +49 (0) 9 11. 81 74 49-0
Fax +49 (0) 9 11. 81 74 49-25
info@woernlein.de
www.woernlein.de

Return deadline
14.12.2016

Hall/Stand

Company

Street

Postcode, Town, Country

Tel

Fax

E-mail

Person to contact

Tel

Fax

Invoice address (only if different)

Order

Stand type (Please enclose plan):



in-line stand



corner stand



head stand



block stand

Stand size: front _____ m x depth _____ m **minimum size: 20 m²**

The rental for the duration of the event includes the following equipment:

Walls

stand partition walls on all closed sides of the stand space (Modul-system: aluminum frame construction; 2.50 m high)

Panel light gray or:

white

Ribbed carpet

including dust sheet, edging tape and disposal, **anthracite or:**

- silver medium blue
 dark blue red
 green orange

Cubicle

2.00 x 1.00 m;
with lockable hinged door

Conference table

Screening off conference area **with string curtain white or:**

Modul-system wall as above

Modular tower with logo

height 1.00 x 0.25 m; 4.00 m;
with single mains socket and cable feed through.
Tower up to 3.00 m height **in color as walls or:**
 black blue
 red
From 3.00 m up to 4.00 m the tower is back-lit and includes digital printing (back-lit)

Printing specified data

2 logos 954 x 955 mm
2 logos on side 204 x 955 mm

Data formats: printable PDF files; also EPS (vector format, fonts converted into paths).

Print lead time: 4 weeks prior to start of exhibition.

In the case of data that cannot be printed directly, processing fees of EUR 83.80/hour apply.

See Online [ExhibitorShop / Stand Construction - Lettering/Prints - Fascia Lettering](#) (contractor: Messebau Wörnlein GmbH). (PDF Form S1.71)

1 laptop shelf on tower, anthracite, 1.00 x 0.40 m

1 bar stool "Z" black

3 shelves (please indicate position) 1.00 x 0.30 m

1 modular leaflet tray DIN A4 portrait (please indicate position)

1 table "Rondo" in color of wall 0.70 m diameter

4 chairs "Rondo", gray or:
 white blue
 beech apple green
 red orange

1 extending spotlight "Collus" 130 W, energy saver, per full 4 m² of stand space; individually adjustable

Continued overleaf!

VAT ID number of exhibitor:

<input type="text"/>	<input type="text"/>	<input type="text"/>	<input type="text"/>	<input type="text"/>	<input type="text"/>	<input type="text"/>	<input type="text"/>	<input type="text"/>	<input type="text"/>	<input type="text"/>	<input type="text"/>	<input type="text"/>	<input type="text"/>	<input type="text"/>	<input type="text"/>	<input type="text"/>	<input type="text"/>	<input type="text"/>	<input type="text"/>
----------------------	----------------------	----------------------	----------------------	----------------------	----------------------	----------------------	----------------------	----------------------	----------------------	----------------------	----------------------	----------------------	----------------------	----------------------	----------------------	----------------------	----------------------	----------------------	----------------------



You can use our practical online aid on the Internet at www.standconfigurator.com to visualize the shape, color and equipment of **your** personal exhibition stand. We will be pleased to advise you personally:

Tel +49 (0) 9 11. 86 06-80 00 or
messeservice@nuernbergmesse.de

Additional services, special equipment and individual requirements are obtainable on request and can be ordered overleaf.

Text for lettering on fascia:

<input type="text"/>	<input type="text"/>	<input type="text"/>	<input type="text"/>	<input type="text"/>	<input type="text"/>	<input type="text"/>	<input type="text"/>	<input type="text"/>	<input type="text"/>	<input type="text"/>	<input type="text"/>	<input type="text"/>	<input type="text"/>	<input type="text"/>	<input type="text"/>	<input type="text"/>	<input type="text"/>	<input type="text"/>	<input type="text"/>
<input type="text"/>	<input type="text"/>	<input type="text"/>	<input type="text"/>	<input type="text"/>	<input type="text"/>	<input type="text"/>	<input type="text"/>	<input type="text"/>	<input type="text"/>	<input type="text"/>	<input type="text"/>	<input type="text"/>	<input type="text"/>	<input type="text"/>	<input type="text"/>	<input type="text"/>	<input type="text"/>	<input type="text"/>	<input type="text"/>

Orders received later than 14 days before the start of the event will be billed an express surcharge of 25 %, subject to a minimum surcharge of EUR 10 per order.

Yes, we order daily cleaning during the exhibition at a total extra price of EUR 1.65/m².

All prices stated are subject to the addition of **VAT at the statutory rate** and **3 % insurance premium**.

* If necessary, NürnbergMesse is entitled to have the service ordered provided by another ServicePartner. In this case, the customer will be notified of the other ServicePartner in good time.

With our authorized signature below, we acknowledge acceptance of all items of the General and Special Terms of Business of NürnbergMesse and the General Terms of Business and the Special Conditions for Services of the ServicePartner.

We do not require insurance and accept liability for the stand and rented objects.

Place and date

Company stamp and authorized signature

Order (continued)

1 counter

1.00 x 0.50 x 1.00 m; white;
not lockable; 1 shelf
 at extra cost EUR 75.40

1 coat rack with 5 hooks

at extra cost EUR 18.50

1 waste paper basket

at extra cost EUR 8.70

NEW! Including pre-show cleaning
before the start of the exhibition,
removing and disposal of carpet dust
sheet.

Power supply

in the cubicle, rated at 3 kW (AC),
including consumption and 3-way
mains socket.
 Power rating increased from 3 kW
to 6 kW (AC) surcharge EUR 167.50
 Power rating increased from 3 kW
to 9 kW surcharge EUR 237.00

Power supply of more than 9 kW
– see Online ExhibitorShop under
Technical Services – Electricity
supply. (PDF Form S2.10)

Additional equipment
Complete rental stand POLLUX

Order

1. Exclusive variations

1.1 Floor covering (per m²):

Velour

including dust sheet, edging tape
and disposal
 silver EUR 6.70
 anthracite EUR 6.70
 blue EUR 6.70
 red EUR 6.70

False floor

22 mm chipboard; suitable for
laying cables below; aluminum
edging strip
 EUR 23.20

Laminate

with false floor (22 mm) and
aluminum edging strip
 beech EUR 37.40
 maple EUR 37.40
 cherry EUR 37.40
 matt white EUR 61.10
 gloss white EUR 61.10

1.2 Column decoration

Column laminated with film;
 Desired color on request
Column completely laminated with
customer's own graphic;
 Print to customer's requirements
EUR 469.00

Data formats: printable PDF files;
also EPS (vector format, fonts
converted into paths).

Print lead time: 4 weeks prior to
start of exhibition.
In the case of data that cannot be
printed directly, processing fees of
EUR 83.80/hour apply.

See Online ExhibitorShop / Stand
Construction – Lettering/Prints –
Fascia Lettering (contractor:
Messebau Wörnlein GmbH).
(PDF Form S1.71)

2. Additional stand equipment

2.1 Extra leaflet tray/shelf

Leaflet tray EUR 49.00
 Shelf EUR 20.40

2.2 Additional furniture (each):

Table "Rondo" EUR 37.50

light gray white

Chair "Rondo" EUR 21.50

gray white
 apple green red
 orange beech
 blue

Bar stool "Z" black
 EUR 25.00

Wall showcase
(please indicate position)
Wall showcase with base unit
Modul system; size (w x d x h):
0.95 x 0.25 x 2.00 m
 EUR 354.00

2.3 Extra lounge furniture (per item):

Armchair (leather) "Romeo"
 EUR 60.70

Side table (glass)
 EUR 46.40



Cube seat, imitation leather EUR 21.40
 gray anthracite
 red

2.4 Additional spotlight (per piece):
Halogen spotlight "Collus"
130 W with extension arm
 EUR 39.00

Floral stand decoration – see Online ExhibitorShop under Stand Construction – Floral stand decoration / landscaping services.

Exclusive and additional equipment

can be seen in the stand configurator at
www.standconfigurator.com.
More stand equipment components –
see Online ExhibitorShop under **Stand Construction – Extra stand equipment / floor coverings / furniture – Stand equipment** (contractor: Messebau Wörnlein GmbH). (PDF Forms S1.64 – 1.66)

All prices

are subject to the addition of VAT
at the statutory rate and 3 % insurance
premium for stand material and
furniture.

We do not require insurance and
accept liability for any damage
and loss.

The charges for additional equipment are invoiced by our ServicePartner Messebau Wörnlein GmbH.

Design examples with articles at extra cost:

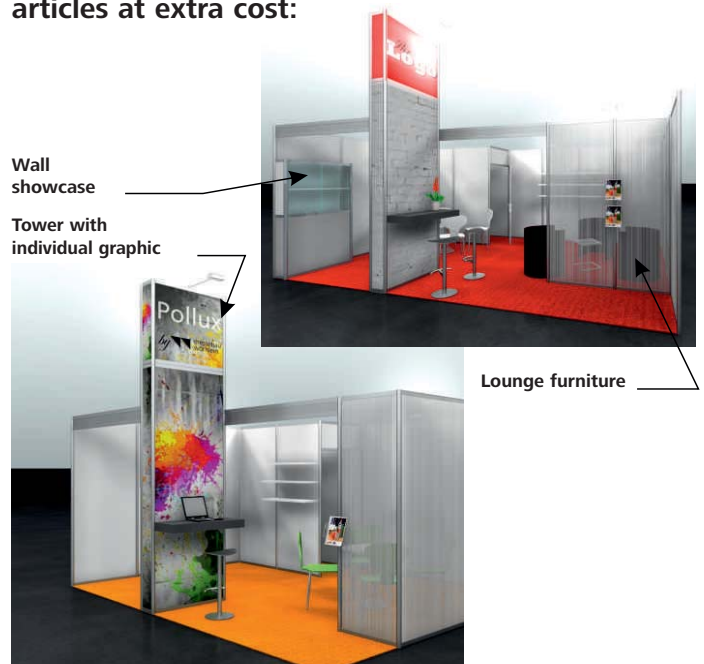

Services on request

The following hourly flat rates are
charged plus VAT at the statutory rate:

- 1. Installation hour at EUR 43.40
- 2. Workshop hour at EUR 41.80
- 3. Machine hour at EUR 61.70

The organizer is responsible for
assembling and dismantling the POLLUX
complete rental stand.

The complete rental stand and its
equipment must not be pasted over,
nailed, painted or damaged in any
other way.

The exhibitor is liable for damage
caused during the rental period and
will be charged with the costs.

Orders received later than 14 days before the start of the event will be billed an express surcharge of 25 %, subject to a minimum surcharge of EUR 10 per order.
With our authorized signature below, we acknowledge acceptance of all items of the General and Special Terms of Business of NürnbergMesse and the General Terms of Business and the Special Conditions for Services of the ServicePartner.

Place and date

Company stamp and authorized signature

Complete rental stand HELIOS

S0.50

Nuremberg, Germany
14-16.3.2017



embeddedworld2017

Exhibition & Conference

... it's a smarter world

Return to
NürnbergMesse GmbH
MesseService
Messezentrum
90471 Nürnberg
Tel +49 (0) 9 11. 86 06-80 00
Fax +49 (0) 9 11. 86 06-80 01
messeservice@nuernbergmesse.de

Contractor *
:mesomondo GmbH
Messezentrum 1
90471 Nürnberg
Tel +49 (0) 9 11. 40 08 35-0
Fax +49 (0) 9 11. 40 08 35-29
info@mesomondo.de
www.mesomondo.de

Return deadline
14.12.2016

Hall/Stand

Company

Street

Postcode, Town, Country

Tel

Fax

E-mail

Person to contact

Tel

Fax

Invoice address (only if different)

Order

Stand type (Please enclose plan):



in-line stand



corner stand



head stand



block stand

Stand size: front _____ m x depth _____ m **minimum size: 15 m²**

The rental for the duration of the event includes the following equipment:

Walls

Stand partition walls on all closed side walls of the stand space, 2.50 m high, white panels

Complete visual wall back-lit

at the back of the stand, **over the whole width**, back-lit wall 3.30 m high, segmented (internal dimensions of segment panel: 0.96 x 0.788 m), white acrylic, can be printed as option.

Logo

in one panel of the visual wall, film plot, single color, see overleaf for surcharge for company logo.

Ribbed carpet anthracite

(including edging tape, dust sheet and disposal) or:

- gray blue red
 green

Cubicle

Size according to stand size, with lockable, white hinged door, side wall in segment design in blue (RAL colors: blue 5017; red 3020; light gray 7035; dark gray 7037; green 6029; yellow 1023) or:

- white red light gray
 dark gray green yellow
(panel above door matches cubicle wall)

Counter "SLIM"

lockable, silver, 0.70 x 0.50 x 1.10 m (W x D x H)

Standing table "Tall"

d = 0.60 m, white top

2 bar stools "Move"

Chrome frame with seat in
 red black

1 coat rack

1 waste paper basket

Power supply

in the cubicle, rated at 3 kW (AC), including consumption and 3-way mains socket.

- Power rating increased from 3 kW to 6 kW (AC) surcharge EUR 167.50
 Power rating increased from 3 kW to 9 kW surcharge EUR 237.00

Power supply of more than 9 kW

– see **Online ExhibitorShop under Technical Services – Electricity supply. (PDF Form S2.10)**

NEW! Including pre-show cleaning

before the start of the exhibition, including removing and disposal of carpet dust sheet.

____ pc. Wide-angle halogen lamp, 400 W, incl. ceiling suspension as additional stand lighting.
Surcharge each EUR 134.00
in halls
3A, 4A, 7A and 11 on request

VAT ID number of exhibitor:

<input type="text"/>	<input type="text"/>	<input type="text"/>	<input type="text"/>	<input type="text"/>	<input type="text"/>	<input type="text"/>	<input type="text"/>	<input type="text"/>	<input type="text"/>	<input type="text"/>	<input type="text"/>	<input type="text"/>	<input type="text"/>	<input type="text"/>	<input type="text"/>	<input type="text"/>	<input type="text"/>	<input type="text"/>	<input type="text"/>
----------------------	----------------------	----------------------	----------------------	----------------------	----------------------	----------------------	----------------------	----------------------	----------------------	----------------------	----------------------	----------------------	----------------------	----------------------	----------------------	----------------------	----------------------	----------------------	----------------------



HELIOS

Complete price EUR 128.90/m²
incl. power supply rated at 3 kW, consumption and pre-show cleaning

You can use our practical online aid on the Internet at www.standconfigurator.com to visualize the shape, color and equipment of **your** personal exhibition stand. We will be pleased to advise you personally:

Tel +49 (0) 9 11. 86 06-80 00 or
messeservice@nuernbergmesse.de

Additional services, special equipment and individual requirements are obtainable on request and can be ordered overleaf.

Orders received later than 14 days before the start of the event will be billed an express surcharge of 25 %, subject to a minimum surcharge of EUR 10 per order.

Yes, we order daily cleaning during the exhibition at a total extra price of EUR 1.65/m².

All prices stated are subject to the addition of **VAT at the statutory rate** and **3 % insurance premium**.

* If necessary, NürnbergMesse is entitled to have the service ordered provided by another ServicePartner. In this case, the customer will be notified of the other ServicePartner in good time.

With our authorized signature below, we acknowledge acceptance of all items of the General and Special Terms of Business of NürnbergMesse and the General Terms of Business and the Special Conditions for Services of the ServicePartner.

We do not require insurance and accept liability for the stand and rented objects.

Place and date

Company stamp and authorized signature

Additional equipment Complete rental stand HELIOS

Order

- 1. Exclusive variations**
- 1.1 Floor covering (surcharge per m²):**
- Velour carpet**
- light gray EUR 5.25
 - blue EUR 5.25
 - anthracite EUR 5.25
- False floor**
63 mm chipboard; suitable for laying cables underneath; aluminum edging strip
- EUR 14.45
- Laminate**
with 63 mm false floor, suitable for laying cables underneath; aluminum edging strip
- Polar oak longstrip wood floor EUR 30.60
 - Maple plank longstrip wood floor EUR 30.60
 - Walnut patchwood longstrip wood floor EUR 30.60
 - Oak Cappuccino 1-strip flooring EUR 30.60
 - Canadian spruce 2-strip plank flooring EUR 30.60
- 1.2 Cubicle:**
Extension per m of extra segment wall, color as per first page
- EUR 79.00
- 1.3 Wall cladding (per m)**
without visible supports, height 2.50 m (surcharge). These walls are just asking to be used for graphics.
- EUR 32.00
- 2. Visual wall**
plastic-coated acrylic panels 3 mm
- 2.1 In other colors (Preis per Platte)**
- other colors on request
- 2.2 Acrylic panel (0.96 x 0.78 m) with single-color film plot**
- EUR 86.30
- 2.3 Printed acrylic panels (digital) for back lighting**
Exhibitor must provide print data 20 days before the event
- (purchase price) EUR 148.80
- 2.4 Acrylic panel**
for backlighting
- (rental price) EUR 94.70
- 2.5 Acrylic panel** across 4 segments, white, ideal for highlighting graphic/logo, (surcharge in addition to rent)
- EUR 111.20
- 2.6 Graphic design for whole area**
- on request
- 2.7 Product display** in the wall
- EUR 188.70
- 2.8 Additional back-lit wall per meter**
- from EUR 266.60

- 2.9 Increasing ob back-lit wall**
Height of wall increased by one additional back-lit segment (W x H: 0.99 x 0.818 m, white acrylic); overall height including extra segment approx. 4.118 m
- _____ panels EUR 93.40
- 3. Extra furniture**
as per first page (price each)
- Standing table "Tall"
 - EUR 38.50
 - Bar stool "Move"
 - EUR 43.00
 - Counter element
 - EUR 144.20

Floral stand decoration – see Online ExhibitorShop under Stand Construction – Floral stand decoration / landscaping services.

Further stand equipment components can be found at **www.mesomondo.de**.

All prices are subject to the addition of VAT at the statutory rate and 3 % insurance premium for stand material and furniture.

- We do not require insurance and accept liability for damage and loss.

Services on request
The following hourly flat rates are charged plus VAT at the statutory rate:

- 1. Working hour** at EUR 49.50
- The organizer is responsible for assembling and dismantling the HELIOS complete rental stand.
- The complete rental stand and its equipment must not be pasted over, nailed, painted or damaged in any other way.
- The exhibitor is liable for damage caused during the rental period and will be charged with the costs.

The charges for additional equipment are invoiced by the ServicePartner.

Remarks: _____

Design example:

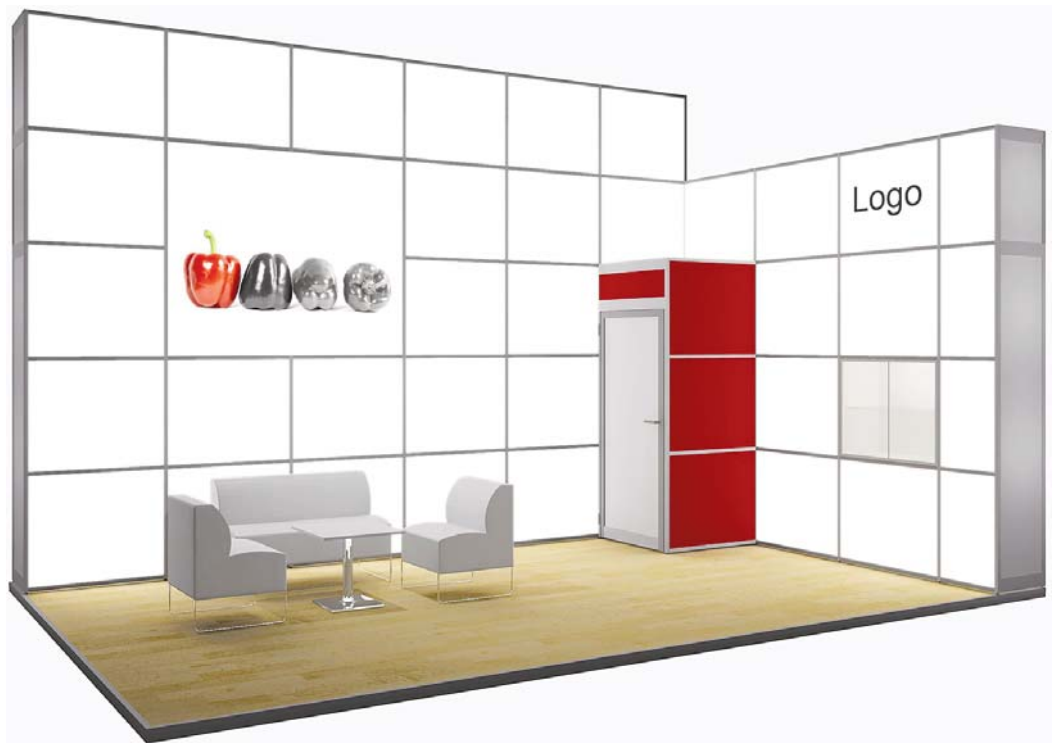

Orders received later than 14 days before the start of the event will be billed an express surcharge of 25 %, subject to a minimum surcharge of EUR 10 per order. With our authorized signature below, we acknowledge acceptance of all items of the General and Special Terms of Business of NürnbergMesse and the General Terms of Business and the Special Conditions for Services of the ServicePartner.

Complete rental stand OBERON

S0.51

Nuremberg, Germany
14-16.3.2017



embeddedworld2017

Exhibition & Conference
... it's a smarter world

Return to
NürnbergMesse GmbH
MesseService
Messezentrum
90471 Nürnberg
Tel +49 (0) 9 11. 86 06-80 00
Fax +49 (0) 9 11. 86 06-80 01
messeservice@nuernbergmesse.de

Contractor *
Messebau Wörnlein GmbH
Messezentrum
D-90471 Nürnberg
Tel +49 (0) 9 11. 81 74 49-0
Fax +49 (0) 9 11. 81 74 49-25
info@woernlein.de
www.woernlein.de

Return deadline
14.12.2016

Hall/Stand

Company

Street

Postcode, Town, Country

Tel

Fax

E-mail

Person to contact

Tel

Fax

Invoice address (only if different)

Order

Stand type (Please enclose plan):



in-line stand



corner stand



head stand



block stand

Stand size: front _____ m x depth _____ m **minimum size: 15 m²**

The rental for the duration of the event includes the following equipment:

Walls

Stand partition walls (modular system) on all closed sides of the stand space; 2.50 m high; Color of wall panel: light gray combined with:
 red blue black
 gray only

Floor covering

Velour carpet

including edging tape, dust sheet and disposal, **silver or:**
 blue red anthracite

Cubicle, approx. 2 m², curved

size according to stand space; with lockable hinged door in same color as walls

2 shelves, light gray

1.00 x 0.30 m; with supports

2 curved fascias (height of top edge: 3.20 m) each 1/4 of a circle (approx. 1.54 x 0.70 m)

Lettering/logo

on fascia; brief company name and place of business in Helvetica medium (or other computer fonts on request) and logo, **black or:**

red blue green

Please enter text and font in "Remarks" box on the right **or:**

graphics as send in

Counter

1/4 circle, external r = 1.00 m; acryl glass front, **back-lit white or:**
 red blue

Orders received later than 14 days before the start of the event will be billed an express surcharge of 25 %, subject to a minimum surcharge of EUR 10 per order.

Yes, we order daily cleaning during the exhibition at a total extra price of EUR 1.65/m².

All prices stated are subject to the addition of **VAT at the statutory rate** and **3 % insurance premium.**

* If necessary, NürnbergMesse is entitled to have the service ordered provided by another ServicePartner. In this case, the customer will be notified of the other ServicePartner in good time.

With our authorized signature below, we acknowledge acceptance of all items of the General and Special Terms of Business of NürnbergMesse and the General Terms of Business and the Special Conditions for Services of the ServicePartner.

We do not require insurance and accept liability for the stand and rented objects.

3 bar stools "Opus" black or:

"Rondo" beech "Rondo" white

1 table "Rondo" light gray

0.70 m diameter; **or:**

beech
 basalt gray

4 chairs "Relax" black or:

"Rondo" beech "Rondo" white

1 coat rack with 5 hooks

1 waste paper basket

1 extending spotlight "Collus"

130 W for each full 3 m² of stand space; silver; individually adjustable

2 spotlights "Collus"

for fascia; 130 W

Power supply

in the cubicle, rated at 3 kW (AC), including consumption and 3-way mains socket.

Power rating increased from 3 kW to 6 kW (AC) surcharge EUR 167.50

Power rating increased from 3 kW to 9 kW surcharge EUR 237.00

Power supply of more than 9 kW

– see **Online ExhibitorShop under Technical Services – Electricity supply.** (PDF Form S2.10)

NEW! Including pre-show cleaning

before the start of the exhibition, removing and disposal of carpet dust sheet.

VAT ID number of exhibitor:

<input type="text"/>	<input type="text"/>	<input type="text"/>	<input type="text"/>	<input type="text"/>	<input type="text"/>	<input type="text"/>	<input type="text"/>	<input type="text"/>	<input type="text"/>	<input type="text"/>	<input type="text"/>	<input type="text"/>	<input type="text"/>	<input type="text"/>	<input type="text"/>	<input type="text"/>	<input type="text"/>	<input type="text"/>	<input type="text"/>
----------------------	----------------------	----------------------	----------------------	----------------------	----------------------	----------------------	----------------------	----------------------	----------------------	----------------------	----------------------	----------------------	----------------------	----------------------	----------------------	----------------------	----------------------	----------------------	----------------------



Complete price EUR 128.90/m²

incl. power supply rated at 3 kW, consumption and pre-show cleaning

You can use our practical online aid on the Internet at www.standconfigurator.com to visualize the shape, color and equipment of **your** personal exhibition stand. We will be pleased to advise you personally:

**Tel +49 (0) 9 11. 86 06-80 00 or
messeservice@nuernbergmesse.de**

Additional services, special equipment and individual requirements are obtainable on request and can be ordered overleaf.

Text for lettering on fascia:

<input type="text"/>	<input type="text"/>	<input type="text"/>	<input type="text"/>	<input type="text"/>	<input type="text"/>	<input type="text"/>	<input type="text"/>	<input type="text"/>	<input type="text"/>	<input type="text"/>	<input type="text"/>	<input type="text"/>	<input type="text"/>	<input type="text"/>	<input type="text"/>	<input type="text"/>	<input type="text"/>	<input type="text"/>	<input type="text"/>
----------------------	----------------------	----------------------	----------------------	----------------------	----------------------	----------------------	----------------------	----------------------	----------------------	----------------------	----------------------	----------------------	----------------------	----------------------	----------------------	----------------------	----------------------	----------------------	----------------------

<input type="text"/>	<input type="text"/>	<input type="text"/>	<input type="text"/>	<input type="text"/>	<input type="text"/>	<input type="text"/>	<input type="text"/>	<input type="text"/>	<input type="text"/>	<input type="text"/>	<input type="text"/>	<input type="text"/>	<input type="text"/>	<input type="text"/>	<input type="text"/>	<input type="text"/>	<input type="text"/>	<input type="text"/>	<input type="text"/>
----------------------	----------------------	----------------------	----------------------	----------------------	----------------------	----------------------	----------------------	----------------------	----------------------	----------------------	----------------------	----------------------	----------------------	----------------------	----------------------	----------------------	----------------------	----------------------	----------------------

Place and date

Company stamp and authorized signature

Additional equipment
Complete rental stand OBERON

Order

1. Exclusive variations

1.1 Cubicle:

Cubicle extension (per m²)
 Extra space EUR 18.20

1.2 Floor covering (per m²):

False floor
22 mm chipboard; suitable for laying cables underneath; aluminum edging strip EUR 23.20

Laminate floor
Laid on 22 mm false floor, aluminum edging strip
 beech EUR 35.00
 maple EUR 35.00
 cherry wood EUR 35.00
 matt white EUR 55.00
 gloss white EUR 55.00

2. Extra stand equipment:

Variation for table & chairs
1 PC table with oval shelf in
 beech
 light gray
 blue
 red



per extra shelf
 light gray EUR 20.40
 anthracite EUR 23.40
 Wall showcase with base unit, size (W x D x H): 0.95 x 0.25 x 1.00 m EUR 381.50

3. Extra furniture (per item)

3.1 per extra round table 0.70 m diameter
 light gray EUR 37.50
 beech EUR 37.50

3.2 Extra chairs

"Rondo"
 beech EUR 21.50
 white EUR 21.50

"Relax"
 black EUR 34.80

3.3 Extra bar stools

"Rondo"
 beech EUR 36.10
 white EUR 41.70

"OPUS"
 black EUR 24.40

4. Extra lighting (per item)

Spotlights
Spotlight "Collus", silver, 130 W
 EUR 39.00

5. Colored digital printing (per m²) on self-adhesive foil (without mounting)
 EUR 52.00

Data formats: printable PDF files; also EPS (vector format, fonts converted into paths).
Print lead time: 4 weeks prior to start of exhibition.
In the case of data that cannot be printed directly, processing fees of EUR 83.80/hour apply.

See Online [ExhibitorShop / Stand Construction - Lettering/Prints - Fascia Lettering](#) (contractor: Messebau Wörnlein GmbH). (PDF Form S1.71)

Floral stand decoration – see Online ExhibitorShop under Stand Construction – Floral stand decoration / landscaping services.

More stand equipment components – see Online ExhibitorShop under [Stand Construction – Extra stand equipment / floor coverings / furniture – Stand equipment](#) (contractor: Messebau Wörnlein GmbH). (PDF Forms S1.64 – 1.66)

All prices are subject to the addition of VAT at the statutory rate and 3 % insurance premium for stand material and furniture.

We do not require insurance and accept liability for damage and loss.

Services on request
The following hourly flat rates are charged plus VAT at the statutory rate:

- 1. Installation hour at EUR 43.40
- 2. Workshop hour at EUR 41.80
- 3. Machine hour at EUR 61.70

The organizer is responsible for assembling and dismantling the OBERON complete rental stand.

The complete rental stand and its equipment must not be pasted over, nailed, painted or damaged in any other way.

The exhibitor is liable for damage caused during the rental period and will be charged with the costs.

The charges for additional equipment are invoiced by our ServicePartner Fa. Messebau Wörnlein GmbH.

Remarks: _____

Design examples with articles at extra cost:



Wall Showcase
Laminated floor cherry wood



Laminated floor white

PC-counter with bar stool

Orders received later than 14 days before the start of the event will be billed an express surcharge of 25 %, subject to a minimum surcharge of EUR 10 per order. With our authorized signature below, we acknowledge acceptance of all items of the General and Special Terms of Business of NürnbergMesse and the General Terms of Business and the Special Conditions for Services of the ServicePartner.

Complete rental stand CALYPSO

S0.60

Nuremberg, Germany
14–16.3.2017



embeddedworld2017

Exhibition & Conference
... it's a smarter world

Return to
NürnbergMesse GmbH
MesseService
Messezentrum
90471 Nürnberg
Tel +49 (0) 9 11. 86 06-80 00
Fax +49 (0) 9 11. 86 06-80 01
messeservice@nuernbergmesse.de

Contractor *
:mesomondo GmbH
Messezentrum 1
90471 Nürnberg
Tel +49 (0) 9 11. 40 08 35-0
Fax +49 (0) 9 11. 40 08 35-29
info@mesomondo.de
www.mesomondo.de

Company

Street

Postcode, Town, Country

Tel

Fax

E-mail

Return deadline
14.12.2016

Hall/Stand

Person to contact

Tel

Fax

Invoice address (only if different)

Order

Stand type (Please enclose plan):



in-line stand



corner stand



head stand



block stand

Stand size: front _____ m x depth _____ m **minimum size: 15 m²**

The rental for the duration of the event includes the following equipment:

Walls

Segmented white stand partition walls on all closed sides of the stand space, 2.50 m high, visible support elements on the front end walls in SYMA MOLTO 90 x 90 mm

Ribbed carpet

including edging tape, dust sheet and disposal, anthracite or:

- gray blue red
 green

Cubicle

Size according to stand size, with lockable, white hinged door, side wall in segment design in colors (RAL colors: blue 5017; red 3020; light gray 7035; dark gray 7037; green 6029; yellow 1023), white or:

- red light gray
 blue green
 dark gray yellow

(panel above door matches cubicle wall)

Tower for effective long-range advertising

Long-range advertising element, SYMA MOLTO 90 x 90 mm, for mounting lighting and graphic elements, front view of column is back-lit height 3.50 m in white or:

- red blue

Printed cloth banner

(4 banner for block stands, 3 for head, in-line and corner stands) with logo, cloth banner 1.80 x 0.81 m
Exhibitor must provide print data 20 days before the event.

Counter

1 lockable counter "SLIDE", 0.99 x 0.50 x 1.10 m, white front, silver body

Table "Avangard"

brushed aluminum, 0.70 m diameter

4 chairs "Jo"

anthracite

1 coat rack

1 waste paper basket

HQI spotlight

1 x 150 W spotlight per 5 m² of stand space

Power supply

in the cubicle, rated at 3 kW (AC), including consumption and 3-way mains socket.

- Power rating increased from 3 kW to 6 kW (AC) surcharge EUR 167.50
 Power rating increased from 3 kW to 9 kW surcharge EUR 237.00

Power supply of more than 9 kW

– see Online ExhibitorShop under **Technical Services – Electricity supply. (PDF Form S2.10)**

NEW! Including pre-show cleaning

before the start of the exhibition, including removing and disposal of carpet dust sheet.

Orders received later than 14 days before the start of the event will be billed an express surcharge of 25 %, subject to a minimum surcharge of EUR 10 per order.

Yes, we order daily cleaning during the exhibition at a total extra price of EUR 1.65/m².

All prices stated are subject to the addition of **VAT at the statutory rate** and **3 % insurance premium.**

* If necessary, NürnbergMesse is entitled to have the service ordered provided by another ServicePartner. In this case, the customer will be notified of the other ServicePartner in good time.

With our authorized signature below, we acknowledge acceptance of all items of the General and Special Terms of Business of NürnbergMesse and the General Terms of Business and the Special Conditions for Services of the ServicePartner.

We do not require insurance and accept liability for the stand and rented objects.

VAT ID number of exhibitor:



Complete price EUR 144.90/m²

incl. power supply rated at 3 kW, consumption and pre-show cleaning

Tel +49 (0) 9 11. 86 06-80 00 or
messeservice@nuernbergmesse.de

Additional services, special equipment and individual requirements are obtainable on request and can be ordered overleaf.

Place and date

Company stamp and authorized signature

Additional equipment
Complete rental stand CALYPSO

Order

1. Exclusive variations

1.1 Floor covering (surcharge per m²):

Velour carpet

- light gray EUR 5.25
- blue EUR 5.25
- anthracite EUR 5.25
- other color on request

False floor

63 mm chipboard; suitable for laying cables underneath; aluminum edging strip

- EUR 14.45

Laminate

with 63 mm false floor, suitable for laying cables underneath; aluminum edging strip

- Polar oak longstrip wood floor EUR 30.60
- Maple plank longstrip wood floor EUR 30.60
- Walnut patchwood longstrip wood floor EUR 30.60
- Oak Cappuccino 1-strip flooring EUR 30.60
- Canadian spruce 2-strip plank flooring EUR 30.60

1.2 Cubicle:

Extension per meter of extra segment wall, color as per first page

- EUR 79.00

2. Extra furniture

as per first page (price each)

- Table EUR 48.50
- Chair EUR 25.60
- Counter element EUR 122.70

3. Extra lighting

- HQI spotlight, 150 W EUR 93.30

Floral stand decoration – see Online ExhibitorShop under Stand Construction – Floral stand decoration / landscaping services.

Further stand equipment components can be found at **www.mesomondo.de**.

All prices

are subject to the addition of VAT at the statutory rate and 3 % insurance premium for stand material and furniture.

- We do not require insurance and accept liability for damage and loss.

Services on request

The following hourly flat rates are charged plus VAT at the statutory rate:

- 1. Working hour** at EUR 49.50

The organizer is responsible for assembling and dismantling the CALYPSO complete rental stand.

The complete rental stand and its equipment must not be pasted over, nailed, painted or damaged in any other way.

The exhibitor is liable for damage caused during the rental period and will be charged with the costs.

The charges for additional equipment are invoiced by the ServicePartner.

Remarks: _____

Design example with products at additional costs:



Orders received later than 14 days before the start of the event will be billed an express surcharge of 25 %, subject to a minimum surcharge of EUR 10 per order.

With our authorized signature below, we acknowledge acceptance of all items of the General and Special Terms of Business of NürnbergMesse and the General Terms of Business and the Special Conditions for Services of the ServicePartner.

Place and date _____

Company stamp and authorized signature _____

Complete rental stand KALLISTO

S0.61

Nuremberg, Germany
14-16.3.2017



embeddedworld2017

Exhibition & Conference
... it's a smarter world

Return to
NürnbergMesse GmbH
MesseService
Messezentrum
90471 Nürnberg
Tel +49 (0) 9 11. 86 06-80 00
Fax +49 (0) 9 11. 86 06-80 01
messeservice@nuernbergmesse.de

Contractor *
Messebau Wörnlein GmbH
Messezentrum
90471 Nürnberg
Tel +49 (0) 9 11. 81 74 49-0
Fax +49 (0) 9 11. 81 74 49-25
info@woernlein.de
www.woernlein.de

Return deadline
14.12.2016

Hall/Stand

Company

Street

Postcode, Town, Country

Tel

Fax

E-mail

Person to contact

Tel

Fax

Invoice address (only if different)

Order

Stand type (Please enclose plan):



in-line stand



corner stand



head stand



block stand

Stand size: front _____ m x depth _____ m **minimum size: 15 m²**

The rental for the duration of the event includes the following equipment:

Walls

Stand partition walls (modular system) on all closed sides of the stand space; 2.50 m high

Color of wall panel light gray or:
 blue red anthracite

Floor covering

Velour carpet
including edging tape, dust sheet and disposal, **silver or:**
 blue red anthracite

Cubicle

size according to stand space; with lockable hinged door with same color as the walls

Ceiling construction

Modular system with aluminum supports (91 x 91 mm), height to top edge = 3.00 m
Corner stand with integrated fascia
0.954 x 0.41 m

Illuminated wall (on cubicle)

2.00 m wide, 3.00 m high;
Fabric covering with digital print, back-lit

Data formats: printable PDF files; also EPS (vector format, fonts converted into paths).

Print lead time: 4 weeks prior to start of exhibition.

In the case of data that cannot be printed directly, processing fees of EUR 83.80/hour apply.

See Online [ExhibitorShop / Stand](#)

[Construction](#) – [Lettering/Prints](#) – [Fascia Lettering](#) (contractor: Messebau Wörnlein GmbH). (PDF Form S1.71)

Counter "Circle"

1.50 x 0.60 x 1.10 m;
gray body; silver front with back-lit colored acrylic glass strips, in white **or:**
 blue red

1 table half-round (h = 0.75 m)

1.125 x 0.96 m, silver, fixed to support, with screen of satinized acrylic glass at head and corner stands

3 chairs „Relax“, leather black

1 bar stool "Coma", anthracite

2 wall leaflet trays (DIN A4, at wall)

1 coat rack with 5 hooks

1 waste paper basket

1 halogen spotlight "Collus"

130 W for each full 4 m² of stand space

Power supply

in the cubicle, rated at 3 kW (AC), including consumption and 3-way mains socket.

Power supply of more than 9 kW

– see Online [ExhibitorShop under Technical Services](#) – [Electricity supply](#). (PDF Form S2.10)

NEW! Including pre-show cleaning before the start of the exhibition, removing and disposal of carpet dust sheet.

Orders received later than 14 days before the start of the event will be billed an express surcharge of 25 %, subject to a minimum surcharge of EUR 10 per order.

Yes, we order daily cleaning during the exhibition at a total extra price of EUR 1.65/m².

All prices stated are subject to the addition of **VAT at the statutory rate** and 3 % **insurance premium**.

* If necessary, NürnbergMesse is entitled to have the service ordered provided by another ServicePartner. In this case, the customer will be notified of the other ServicePartner in good time.

With our authorized signature below, we acknowledge acceptance of all items of the General and Special Terms of Business of NürnbergMesse and the General Terms of Business and the Special Conditions for Services of the ServicePartner.

We do not require insurance and accept liability for the stand and rented objects.

VAT ID number of exhibitor:

<input type="text"/>	<input type="text"/>	<input type="text"/>	<input type="text"/>	<input type="text"/>	<input type="text"/>	<input type="text"/>	<input type="text"/>	<input type="text"/>	<input type="text"/>	<input type="text"/>	<input type="text"/>	<input type="text"/>	<input type="text"/>	<input type="text"/>	<input type="text"/>	<input type="text"/>	<input type="text"/>	<input type="text"/>	<input type="text"/>
----------------------	----------------------	----------------------	----------------------	----------------------	----------------------	----------------------	----------------------	----------------------	----------------------	----------------------	----------------------	----------------------	----------------------	----------------------	----------------------	----------------------	----------------------	----------------------	----------------------

KALLISTO



Complete price EUR 144.90/m²
incl. power supply rated at 3 kW, consumption and pre-show cleaning

Tel +49 (0) 9 11. 86 06-80 00 or
messeservice@nuernbergmesse.de

Additional services, special equipment and individual requirements are obtainable on request and can be ordered overleaf.

Fascia lettering (block letters):

<input type="text"/>	<input type="text"/>	<input type="text"/>	<input type="text"/>	<input type="text"/>	<input type="text"/>	<input type="text"/>	<input type="text"/>	<input type="text"/>	<input type="text"/>	<input type="text"/>	<input type="text"/>	<input type="text"/>	<input type="text"/>	<input type="text"/>	<input type="text"/>	<input type="text"/>	<input type="text"/>	<input type="text"/>	<input type="text"/>
----------------------	----------------------	----------------------	----------------------	----------------------	----------------------	----------------------	----------------------	----------------------	----------------------	----------------------	----------------------	----------------------	----------------------	----------------------	----------------------	----------------------	----------------------	----------------------	----------------------

<input type="text"/>	<input type="text"/>	<input type="text"/>	<input type="text"/>	<input type="text"/>	<input type="text"/>	<input type="text"/>	<input type="text"/>	<input type="text"/>	<input type="text"/>	<input type="text"/>	<input type="text"/>	<input type="text"/>	<input type="text"/>	<input type="text"/>	<input type="text"/>	<input type="text"/>	<input type="text"/>	<input type="text"/>	<input type="text"/>
----------------------	----------------------	----------------------	----------------------	----------------------	----------------------	----------------------	----------------------	----------------------	----------------------	----------------------	----------------------	----------------------	----------------------	----------------------	----------------------	----------------------	----------------------	----------------------	----------------------

Place and date

Company stamp and authorized signature

Additional equipment Complete rental stand KALLISTO

Order

1. Exclusive variations

1.1 Extra wall fittings (per item)

A conference cubicle can be included for larger stands (see design examples):

MODUL-wall element, 3.00 m high

- light gray EUR 75.40
- colored EUR 129.60
- acrylic glass up to 2.50 m high EUR 148.40

1.2 Floor covering (per m²):

False floor

22 mm chipboard; suitable for laying cables underneath; aluminum edging strip

- EUR 23.20

Laminate floor

Laid on 22 mm false floor, aluminum edging strip

- beech EUR 35.00
- maple EUR 35.00
- cherry wood EUR 35.00
- matt white EUR 55.00
- gloss white EUR 55.00

2. Variants:

2.1 Individual color for illuminated strip at counter

Desired color _____
 EUR 23.10

2.2 Variation for "Relax" table and chairs:

3 "Coma" bar stools and table
Half-round, h = 1.10 m
 EUR 38.70

3. Extra stand equipment:

3.1 Wall showcase

Wall showcase with base unit system; Size (w x d x h): 0.95 x 0.25 x 2.00 m
 EUR 350.00

3.2 Extra leaflet tray/shelf

- Leaflet tray EUR 49.00
- Shelf, light gray EUR 31.40

4. Extra furniture (per item):

4.1 Counter "Circle" EUR 305.80

1.50 x 0.60 x 1.10 m; gray body; silver front with back-lit colored acrylic glass strips
 white blue red

4.2 Chair "Relax"

- Leather black EUR 34.80

4.3 Bar stool "Coma"

- anthracite EUR 42.80

4.4 Table round 0.70 m diameter

- light gray EUR 37.50
- beech EUR 37.50
- anthracite EUR 37.50

4.5 Table square 0.70 x 0.70 m

- light gray EUR 26.00
- beech EUR 26.00
- anthracite EUR 26.00

4.6 Table square 1.20 x 0.70 m

- light gray EUR 33.60
- beech EUR 33.00
- anthracite EUR 37.00

5. Additional spotlight (per piece):

Halogen spotlight "Collus"

130 W with extension arm
 EUR 39.00

6. Colored digital print (per m²)

on self-adhesive film

(without mounting)
 EUR 52.00

Data formats: printable PDF files; also EPS (vector format, fonts converted into paths).

Print lead time: 4 weeks prior to start of exhibition.

In the case of data that cannot be printed directly, processing fees of EUR 83.80/hour apply.

See Online [ExhibitorShop](#) / [Stand Construction](#) - [Lettering/Prints](#) - [Fascia Lettering](#) (contractor: Messebau Wörnlein GmbH). (PDF Form S1.71)

Floral stand decoration - see Online [ExhibitorShop](#) under [Stand Construction](#) - [Floral stand decoration / landscaping services](#).

Exclusive and additional equipment can be seen in the stand configurator at www.standconfigurator.com.

More stand equipment components - see Online [ExhibitorShop](#) under [Stand Construction](#) - [Extra stand equipment / floor coverings / furniture](#) - [Stand equipment](#) (contractor: Messebau Wörnlein GmbH). (PDF Forms S1.64 - 1.66)

All prices

are subject to the addition of VAT at the statutory rate and 3 % insurance premium for stand material and furniture.

- We do not require insurance and accept liability for damage and loss.

Services on request

The following hourly flat rates are charged plus VAT at the statutory rate:

1. Installation hour at EUR 43.40
2. Workshop hour at EUR 41.80
3. Machine hour at EUR 61.70

The organizer is responsible for assembling and dismantling the KALLISTO complete rental stand.

The complete rental stand and its equipment must not be pasted over, nailed, painted or damaged in any other way.

The exhibitor is liable for damage caused during the rental period and will be charged with the costs.

The charges for additional equipment are invoiced by the ServicePartner.

Remarks: _____

Design examples with articles at extra cost:



Wall Showcase
Laminat white

Additional wall construction:
meeting room

Variation:
3 bar stools and high table

Laminate marple floor

Orders received later than 14 days before the start of the event will be billed an express surcharge of 25 %, subject to a minimum surcharge of EUR 10 per order.

With our authorized signature below, we acknowledge acceptance of all items of the General and Special Terms of Business of NürnbergMesse and the General Terms of Business and the Special Conditions for Services of the ServicePartner.

Nuremberg, Germany
14-16.3.2017



embeddedworld2017

Exhibition & Conference
... it's a smarter world

Return to
NürnbergMesse GmbH
MesseService
Messezentrum
90471 Nürnberg
Tel +49 (0) 9 11. 86 06-80 00
Fax +49 (0) 9 11. 86 06-80 01
messeservice@nuernbergmesse.de

Contractor *
:mesomondo GmbH
Messezentrum 1
90471 Nürnberg
Tel +49 (0) 9 11. 40 08 35-0
Fax +49 (0) 9 11. 40 08 35-29
info@mesomondo.de
www.mesomondo.de

Return deadline
14.12.2016

Hall/Stand

Company

Street

Postcode, Town, Country

Tel

Fax

E-mail

Person to contact

Tel

Fax

Invoice address (only if different)

Order

Stand type (Please enclose plan):



in-line stand



corner stand



head stand



block stand

Stand size: front _____ m x depth _____ m **minimum size: 24 m²**

The rental for the duration of the event includes the following equipment:

Walls

conventional walls, white, height 2.50 m, on all closed sides of the stand space (no system material visible)

Ribbed carpet

including dust sheet and disposal, anthracite; with false floor of chipboard and all-round aluminum edging strip or:

green gray red blue

Cubicle

approx. 3 m², with lockable hinged door, height 2.50 m, segmented side walls, acrylic glass panels, white or:

orange blue

Visual wall (on the cubicle)

height 4.00 m, conventional wall design, white, with 6 sockets for mounting shelves or leaflet holders with 1 shelf, 1.50 x 0.20 m, white

Light box (on the cubicle)

large, back-lit on one side, including digital print on fabric, width 2.00 m, height 3.00 m

Lettering an Visualwand (back-lit)

light box, back-lit on one side, including 1 logo digital printing, width 1.50 m, height 0.40 m
Exhibitor must provide print data 20 days before the event.

1 table

silver frame, white top; 0.70 m diameter

4 chairs

"Bonni", chrome frame, upholstered, black or:
 red blue

1 counter "Madrid"

white, lockable
(W x D x H) 1.70 x 0.60 x 1.10 m

Alternative to seating group (1 table and 4 "Bonni" chairs) for a surcharge EUR 296.00

1 "Toledo 130" high table (130 x 0.60 x 1.10 m) and 4 "New Samba" bar stools (transparent plastic)

At extra cost

1 coat rack EUR 19.90
 1 waste paper basket EUR 8.70

1 bar stool

1 room divider

white, width suitable to stand size, depth approx. 0.30 m, height 0.80 m, including plants

Continued overleaf!

VAT ID number of exhibitor:



SIRIUS



Complete price EUR 157.90/m²
incl. power supply rated at 6 kW, consumption and pre-show cleaning

You can use our practical online aid on the Internet at www.standconfigurator.com to visualize the shape, color and equipment of **your** personal exhibition stand. We will be pleased to advise you personally:

Tel +49 (0) 9 11. 86 06-80 00 or
messeservice@nuernbergmesse.de

Additional services, special equipment and individual requirements are obtainable on request and can be ordered overleaf.

Orders received later than 14 days before the start of the event will be billed an express surcharge of 25 %, subject to a minimum surcharge of EUR 10 per order.

Yes, we order daily cleaning during the exhibition at a total extra price of EUR 1.65/m².

All prices stated are subject to the addition of **VAT at the statutory rate** and **3 % insurance premium.**

* If necessary, NürnbergMesse is entitled to have the service ordered provided by another ServicePartner. In this case, the customer will be notified of the other ServicePartner in good time.

With our authorized signature below, we acknowledge acceptance of all items of the General and Special Terms of Business of NürnbergMesse and the General Terms of Business and the Special Conditions for Services of the ServicePartner.

We do not require insurance and accept liability for the stand and rented objects.

Place and date

Company stamp and authorized signature

Order (continued)

Lighting

one 400 watt HQI flat spotlight per full 8 m² of stand space, mounted on a 30 x 30 cm truss and suspended from the ceiling, position: truss mounted at front of stand (on longer gangway side for corner stands) approx. 1.50 m from edge height: top edge of truss approx. 5.00 m (unless a lower maximum height is specified for the event)

Power supply

in the cubicle, rated at 6 kW (AC), including consumption and 3-way mains socket.
 Power rating increased from 6 kW to 9 kW (AC) surcharge EUR 180.50

Power supply of more than 9 kW – see Online ExhibitorShop under Technical Services – Electricity supply. (PDF Form S2.10)

NEW! Including pre-show cleaning before the start of the exhibition, including removing and disposal of carpet dust sheet.

Additional equipment
Complete rental stand SIRIUS

Order

1. Floor covering (per m²):

- Surcharge for laminated floor
 Polar oak longstrip wood floor EUR 30.60
 Maple plank longstrip wood floor EUR 30.60
 Walnut patchwood longstrip wood floor EUR 30.60
 Oak Cappuccino 1-strip flooring EUR 30.60
 Canadian spruce 2-strip plank flooring EUR 30.60

2. Larger cubicle

- on request

3. Kabinenwände seitlich (pro Wand)

- Wandelemente segmentiert, hinterleuchtet, Höhe 2.50 m, Acrylglas
 white EUR 187.30
 blue EUR 187.30
 orange EUR 187.30

4. Height of wall

- increases to 3.50 m height, white (per m) EUR 18.25

5. Additional equipment on visual wall

5.1 Display unit on visual wall (each)

- Extra shelf, white, including shelf holder, 1.50 x 0.20 m
 EUR 113.40
Acryl glass leaflet holder, DIN A4
 EUR 61.40

5.2 LCD display, 40" LCD, including

- USB player modul (MPEG4, H 264, AVI, FLU, WMV, MOV), including mounting on visual wall
 EUR 430.00

5.3 Mounting will for display

- (on visual wall), white, 2.00 x 3.00 m EUR 202.00

6. Additional wall decoration

- 6.1 Graphics (per m²)**
Digital print for wall element, print including assembly
 EUR 62.00
6.2 LCD display, 40" LCD, including USB player modul (MPEG4, H 264, AVI, FLU, WMV, MOV), including mounting on visual wall
 EUR 430.00

7. Graphics for counter or wall (per m²)

- digital printing including printing and mounting
 EUR 62.00

8. Furniture

- Further furniture
 on request

Exclusive and additional equipment can be seen in the stand configurator at www.standconfigurator.com. Additional stand equipment can be found at www.mesomondo.de.

All prices

are subject to the addition of VAT at the statutory rate and 3 % insurance premium for stand material and furniture.

- We do not require insurance and accept liability for damage and loss.

Services on request

The following hourly flat rates are charged plus VAT at the statutory rate:

1. Working hour at EUR 49.50

The organizer is responsible for assembling and dismantling the SIRIUS complete rental stand.

The complete rental stand and its equipment must not be pasted over, nailed, painted or damaged in any other way.

The exhibitor is liable for damage caused during the rental period and will be charged with the costs.

The charges for additional equipment are invoiced by the ServicePartner.

Remarks: _____

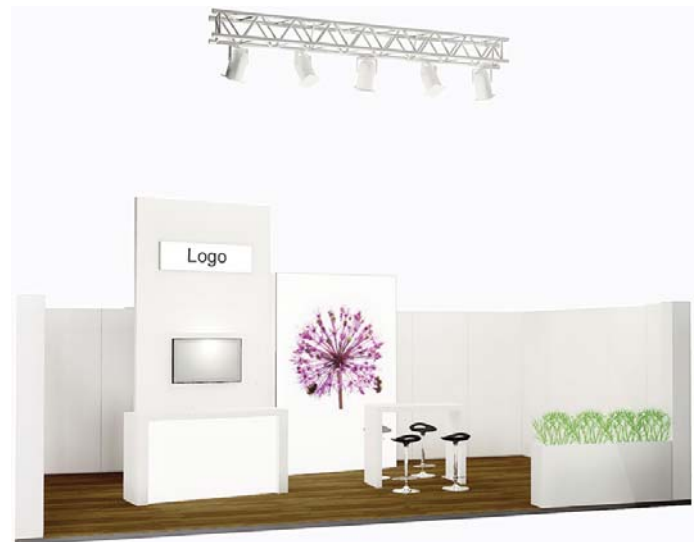

Orders received later than 14 days before the start of the event will be billed an express surcharge of 25 %, subject to a minimum surcharge of EUR 10 per order.

With our authorized signature below, we acknowledge acceptance of all items of the General and Special Terms of Business of NürnbergMesse and the General Terms of Business and the Special Conditions for Services of the ServicePartner.

Place and date _____

Company stamp and authorized signature _____

Order (continued)

Power supply
in the cubicle, rated at 3 kW (AC), including consumption and 3-way mains socket.

- Power rating increased from 3 kW to 6 kW (AC) surcharge EUR 167.50
- Power rating increased from 3 kW to 9 kW surcharge EUR 237.00

Power supply of more than 9 kW
– see Online ExhibitorShop under **Technical Services – Electricity supply.** (PDF Form S2.10)

NEW! Including pre-show cleaning
before the start of the exhibition, removing and disposal of carpet dust sheet.

Additional equipment
Complete rental stand PLUTO

Order

1. Exclusive variations

1.1 Cubicle:

Larger cubicle (per m²)

- additional space EUR 18.20

1.2 Floor covering (per m²):

False floor

22 mm chipboard; suitable for laying cables below; aluminum edging strip

- EUR 23.20

Laminate

with false floor (22 mm) and aluminum edging strip

- beech EUR 35.00
- maple EUR 35.00
- cherry EUR 35.00
- matt white EUR 55.00
- gloss white EUR 55.00

1.3 Design wall element (each):

- milky acryl glass EUR 82.60
- satinized red EUR 118.30
- satinized blue EUR 118.30
- satinized smoke gray EUR 118.30

1.4 Counter front:

- milky acryl glass EUR 36.60
- satinized red EUR 60.70
- satinized blue EUR 60.70
- satinized smoke gray EUR 60.70
- back-lit red EUR 115.10
- back-lit blue EUR 115.10
- back-lit gray EUR 115.10

2. Additional stand equipment:

2.1 Variations for slatted wall (2 items)

- beech EUR 48.70

Additional slatted walls

- white EUR 81.40
- light gray EUR 104.60
- beech EUR 104.60

2.2 Per additional shelf

- white EUR 33.50
- light gray EUR 33.50
- beech EUR 33.50
- anthracite EUR 33.50

2.3 Per showcase for mounting in slots

0.26 x 0.35 x 0.26 m; acrylic glass; not lockable

- EUR 66.90

2.4 Per leaflet holder (DIN A4) for mounting in slots 6 (portrait)

- plastic EUR 14.20
- perforated metal EUR 49.00
- plastic sloping EUR 23.10

2.5 Per pedestal "U"

0.50 x 0.50 m; anthracite

- 0.75 m high EUR 117.30
- 1.05 m high EUR 129.80
- 1.35 m high EUR 142.30

Showcase "U"

pedestal "U" with showcase (height 50 cm) on top

- pedestal 0.75 m EUR 151.70
- pedestal 1.05 m EUR 164.10
- pedestal 1.35 m EUR 177.00

3. Additional furniture (each):

3.1 Table

0.70 m diameter "Rondo"

- white EUR 37.50
- light gray EUR 37.50
- beech EUR 37.50

3.2 Chairs

- "Thonet" black EUR 41.70
- "m.o.d" with arm rest EUR 38.60
- "m.o.d" without arm rest EUR 38.60
- "Relax" black EUR 34.80

3.3 Bar stools

- "Rondo" white EUR 41.70
- "Rondo" beech EUR 36.10
- "Opus" black EUR 24.40

4. Additional lighting (each)

Halogen spotlight

100 W, mounted on power rail
 EUR 39.20

Floral stand decoration – see Online ExhibitorShop under **Stand Construction – Floral stand decoration / landscaping services.**

Exclusive and additional equipment
can be seen in the stand configurator at **www.standconfigurator.com.**

More stand equipment components – see Online ExhibitorShop under **Stand Construction – Extra stand equipment / floor coverings / furniture – Stand equipment** (contractor: Messebau Wörnlein GmbH). (PDF Forms S1.64 – 1.66)

All prices
are subject to the addition of VAT at the statutory rate and 3 % insurance premium for stand material and furniture.

- We do not require insurance and accept liability for damage and loss.

Services on request

The following hourly flat rates are charged plus VAT at the statutory rate:

1. Installation hour at EUR 43.40
2. Workshop hour at EUR 41.80
3. Machine hour at EUR 61.70

The organizer is responsible for assembling and dismantling the PLUTO complete rental stand.

The complete rental stand and its equipment must not be pasted over, nailed, painted or damaged in any other way.

The exhibitor is liable for damage caused during the rental period and will be charged with the costs.

The charges for additional equipment are invoiced by the ServicePartner.

Remarks: _____

Design examples with articles at extra cost:



Orders received later than 14 days before the start of the event will be billed an express surcharge of 25 %, subject to a minimum surcharge of EUR 10 per order. With our authorized signature below, we acknowledge acceptance of all items of the General and Special Terms of Business of NürnbergMesse and the General Terms of Business and the Special Conditions for Services of the ServicePartner.

Place and date _____

Company stamp and authorized signature _____

Nuremberg, Germany
14-16.3.2017



embeddedworld2017

Exhibition & Conference
... it's a smarter world

Return to
NürnbergMesse GmbH
MesseService
Messezentrum
90471 Nürnberg
Tel +49 (0) 9 11. 86 06-80 00
Fax +49 (0) 9 11. 86 06-80 01
messeservice@nuernbergmesse.de

Contractor *
Messebau Wörnlein GmbH
Messezentrum
90471 Nürnberg
Tel +49 (0) 9 11. 81 74 49-0
Fax +49 (0) 9 11. 81 74 49-25
info@woernlein.de
www.woernlein.de

Company

Street

Postcode, Town, Country

Tel

Fax

E-mail

Return deadline
14.12.2016

Hall/Stand

Person to contact

Tel

Fax

Invoice address (only if different)

Order

Stand type (Please enclose plan):



in-line stand



corner stand



head stand



block stand

Stand size: front _____ m x depth _____ m **minimum size: 15 m²**

The rental for the duration of the event includes the following equipment:

Walls

Stand partition walls (no system material visible) on all closed sides of the stand space; 2.50 m high, **white or:**

- light gray ivory

Floor covering

Velour carpet

including edging tape, dust sheet and disposal, **silver or:**

- anthracite red blue

Cubicle

size according to stand space; with lockable hinged door in same color as walls

1 slatted wall

2.50 x 1.00 m; with grooves for fixing various presentation aids, **white or:**

- anthracite beech

2 shelves for slatted wall

1.00 x 0.30 m; white or:

- anthracite beech

Illuminated wall, 0.80 x 2.38 m

(on cubicle):

- Acrylic glass, satinized and back-lit
 Display: Print on self-adhesive film

Printing based on provided data (see text below).

Ceiling construction

Modul-system Aluminum supports (91 x 91 mm), overall height = 3.50 m

1 LED-Fascia (please indicate position)

Light box 1.50 x 0.50 m; with digital print on fabric at front, back-lit with LEDs. Printing based on provided data (see text below).

Data formats: printable PDF files; also EPS (vector format, fonts converted into paths).

Print lead time: 4 weeks prior to start of exhibition.

In the case of data that cannot be printed directly, processing fees of EUR 83.80/hour apply.

See Online [ExhibitorShop / Stand Construction - Lettering/Prints - Fascia Lettering](#) (contractor: Messebau Wörnlein GmbH). (PDF Form S1.71)

Counter

1.00 x 0.60 x 1.10 m; "L-Form"; fixed to support in variable position, **anthracite or:**

- beech

2 bar stools "Coma", anthracite

1 Side table "Romeo"

silver, with satinized glass top

2 Arm chair "Romeo", black leather

1 coat rack with 5 hooks

1 waste paper basket

1 halogen spotlight "Collus"

130 W for each full 4 m² of stand space

Continued overleaf!

VAT ID number of exhibitor:

<input type="text"/>	<input type="text"/>	<input type="text"/>	<input type="text"/>	<input type="text"/>	<input type="text"/>	<input type="text"/>	<input type="text"/>	<input type="text"/>	<input type="text"/>	<input type="text"/>	<input type="text"/>	<input type="text"/>	<input type="text"/>	<input type="text"/>	<input type="text"/>	<input type="text"/>	<input type="text"/>	<input type="text"/>	<input type="text"/>
----------------------	----------------------	----------------------	----------------------	----------------------	----------------------	----------------------	----------------------	----------------------	----------------------	----------------------	----------------------	----------------------	----------------------	----------------------	----------------------	----------------------	----------------------	----------------------	----------------------



Complete price EUR 171.00/m²
incl. power supply rated at 3 kW, consumption and pre-show cleaning

Tel +49 (0) 9 11. 86 06-80 00 or
messeservice@nuernbergmesse.de

Additional services, special equipment and individual requirements are obtainable on request and can be ordered overleaf.

Fascia lettering (block letters):

<input type="text"/>	<input type="text"/>	<input type="text"/>	<input type="text"/>	<input type="text"/>	<input type="text"/>	<input type="text"/>	<input type="text"/>	<input type="text"/>	<input type="text"/>	<input type="text"/>	<input type="text"/>	<input type="text"/>	<input type="text"/>	<input type="text"/>	<input type="text"/>	<input type="text"/>	<input type="text"/>	<input type="text"/>	<input type="text"/>
<input type="text"/>	<input type="text"/>	<input type="text"/>	<input type="text"/>	<input type="text"/>	<input type="text"/>	<input type="text"/>	<input type="text"/>	<input type="text"/>	<input type="text"/>	<input type="text"/>	<input type="text"/>	<input type="text"/>	<input type="text"/>	<input type="text"/>	<input type="text"/>	<input type="text"/>	<input type="text"/>	<input type="text"/>	<input type="text"/>

Orders received later than 14 days before the start of the event will be billed an express surcharge of 25 %, subject to a minimum surcharge of EUR 10 per order.

Yes, we order daily cleaning during the exhibition at a total extra price of EUR 1.65/m².

All prices stated are subject to the addition of **VAT at the statutory rate** and 3 % **insurance premium**.

* If necessary, NürnbergMesse is entitled to have the service ordered provided by another ServicePartner. In this case, the customer will be notified of the other ServicePartner in good time.

With our authorized signature below, we acknowledge acceptance of all items of the General and Special Terms of Business of NürnbergMesse and the General Terms of Business and the Special Conditions for Services of the ServicePartner.

We do not require insurance and accept liability for the stand and rented objects.

Place and date

Company stamp and authorized signature

Order (continued)

Power supply
in the cubicle, rated at 3 kW (AC), including consumption and 3-way mains socket.

- Power rating increased from 3 kW to 6 kW (AC) surcharge EUR 167.50
- Power rating increased from 3 kW to 9 kW surcharge EUR 237.00

Power supply of more than 9 kW – see Online ExhibitorShop under **Technical Services – Electricity supply**. (PDF Form S2.10)

NEW! Including pre-show cleaning before the start of the exhibition, removing and disposal of carpet dust sheet.

Additional equipment
Complete rental stand VESTA

Order

1. **Exclusive variations**
 - 1.1 **Cubicle:**
 - Cubicle extension (per m²)**
 - Extra space EUR 18.20
 - 1.2 **Floor covering (per m²):**
 - False floor**
22 mm chipboard; suitable for laying cables underneath; aluminum edging strip
 - EUR 23.20
 - Laminate floor**
Laid on 2 mm false floor, aluminum edging strip
 - beech EUR 35.00
 - maple EUR 35.00
 - cherry wood EUR 35.00
 - matt white EUR 55.00
 - gloss white EUR 55.00
 - 1.3 **Variation for illuminated wall:**
 - Wall showcase**
with lighting and 3 glass shelves
showcase size (W x D x H):
0.70 x 0.30 x 1.00 m
 - EUR 367.20
2. **Extra stand equipment:**
 - 2.1 **Extra slatted walls**
 - light gray EUR 104.60
 - white EUR 81.40
 - anthracite EUR 104.60
 - beech EUR 104.60
 - 2.2 **Extra shelf (each)**
 - white EUR 33.50
 - light gray EUR 33.50
 - beech EUR 33.50
 - 2.3 **Product display units for slatted walls:**
 - Acrylic glass showcase**
for mounting in slots;
0.26 x 0.35 x 0.26 m;
not lockable
 - EUR 66.90
 - Leaflet holder for slatted walls**
(plastic, DIN A4 portrait):
 - vertical, plastic EUR 14.20
 - perforated metal EUR 49.00
 - sloping, plastic EUR 23.00
3. **Equipment for aluminum construction (per item):**
 - Extra LED-light box**
 - EUR 187.70
 - Leaflet tray**
(metal, DIN A4 portrait)
 - EUR 49.00
4. **Extra furniture (per item):**
 - Counter, "L" form fixed to supports**
 - beech EUR 167.30
 - anthracite EUR 167.30
 Please indicate position.
 - Bar stool "Coma"**
 - EUR 42.80
 - Side table "Romeo", glass**
 - EUR 46.40
 - Leather chair "Romeo"**
 - black leather EUR 60.70
 - Sofa „Romeo”, black imitation leather**
 - EUR 152.00
5. **Spotlight "Collus", 130 W**
 - EUR 39.00
6. **Colored digital printing (per m²)**
 - 6.1 **on 140-190 g/m² paper**
(without mounting)
 - EUR 38.30
 - 6.2 **on Self-adhesive film**
(without mounting)
 - EUR 52.00

Data formats: printable PDF files; also EPS (vector format, fonts converted into paths).
Print lead time: 4 weeks prior to start of exhibition.
In the case of data that cannot be printed directly, processing fees of EUR 83.80/hour apply.

Floral stand decoration – see Online ExhibitorShop under **Stand Construction – Floral stand decoration / landscaping services**.

More stand equipment components – see Online ExhibitorShop under **Stand Construction – Extra stand equipment / floor coverings / furniture – Stand equipment** (contractor: Messebau Wörnlein GmbH). (PDF Forms S1.64 – 1.66)

All prices are subject to the addition of VAT at the statutory rate and 3 % insurance premium for stand material and furniture.

- We do not require insurance and accept liability for damage and loss.

Services on request
The following hourly flat rates are charged plus VAT at the statutory rate:

The charges for additional equipment are invoiced by the ServicePartner.

Remarks: _____

- | | |
|----------------------|--------------|
| 1. Installation hour | at EUR 43.40 |
| 2. Workshop hour | at EUR 41.80 |
| 3. Machine hour | at EUR 61.70 |

The organizer is responsible for assembling and dismantling the VESTA complete rental stand.

The complete rental stand and its equipment must not be pasted over, nailed, painted or damaged in any other way.

The exhibitor is liable for damage caused during the rental period and will be charged with the costs.

Design examples with articles at extra cost:



Orders received later than 14 days before the start of the event will be billed an express surcharge of 25 %, subject to a minimum surcharge of EUR 10 per order.
With our authorized signature below, we acknowledge acceptance of all items of the General and Special Terms of Business of NürnbergMesse and the General Terms of Business and the Special Conditions for Services of the ServicePartner.

Place and date _____

Company stamp and authorized signature _____

Complete rental stand SATURN

S0.95

Nuremberg, Germany
14–16.3.2017



embeddedworld2017

Exhibition&Conference
... it's a smarter world

Return to
NürnbergMesse GmbH
MesseService
Messezentrum
90471 Nürnberg
Tel +49 (0) 9 11. 86 06-80 00
Fax +49 (0) 9 11. 86 06-80 01
messeservice@nuernbergmesse.de

Contractor *
:mesomondo GmbH
Messezentrum 1
90471 Nürnberg
Tel +49 (0) 9 11. 40 08 35-0
Fax +49 (0) 9 11. 40 08 35-29
info@mesomondo.de
www.mesomondo.de

Return deadline
14.12.2016

Hall/Stand

Company

Street

Postcode, Town, Country

Tel

Fax

E-mail

Person to contact

Tel

Fax

Invoice address (only if different)

Order

Stand type (Please enclose plan):



in-line stand



corner stand



head stand



block stand

Stand size: front _____ m x depth _____ m **minimum size: 28 m²**

The rental for the duration of the event includes the following equipment:

Walls

white stand partition walls in grid design on all closed sides of the stand space (Syma system; 3.00 m high)

Ribbed carpet

with false floor on chipboard and all-round aluminum edging strip, including protective plastic covering, edging tape and disposal; anthracite or:

red blue

Cubicle

size according to stand space; white; panel design; with lockable door; same design as wall

2 visuals

in grid design, with white acrylic glass, back-lit, 4.00 m high, 1.00 m width, back panels white

Lettering/logo

1 color plot, black; please enter text in "Remarks" box on the right

2 side table "Stylus"

round, 0.50 cm; chrome base with glass top; 0.51 m high

6 Lounge stool "Dado"

chromium frame, upholstery synthetic leather, white

Spotlight

130 W, 1 spotlight for each full 4 m² stand space; including low-voltage spotlights built into ceiling

Power supply

in the cubicle, rated at 6 kW (AC), including consumption and 3-way mains socket.

Power rating increased from 6 kW to 9 kW (AC) surcharge EUR 180.50

Power supply of more than 9 kW – see Online ExhibitorShop under Technical Services – Electricity supply. (PDF Form S2.10)

NEW! Including pre-show cleaning before the start of the exhibition, including removing and disposal of carpet dust sheet.

VAT ID number of exhibitor:

<input type="text"/>	<input type="text"/>	<input type="text"/>	<input type="text"/>	<input type="text"/>	<input type="text"/>	<input type="text"/>	<input type="text"/>	<input type="text"/>	<input type="text"/>	<input type="text"/>	<input type="text"/>	<input type="text"/>	<input type="text"/>	<input type="text"/>	<input type="text"/>	<input type="text"/>	<input type="text"/>	<input type="text"/>	<input type="text"/>
----------------------	----------------------	----------------------	----------------------	----------------------	----------------------	----------------------	----------------------	----------------------	----------------------	----------------------	----------------------	----------------------	----------------------	----------------------	----------------------	----------------------	----------------------	----------------------	----------------------



SATURN

Complete price EUR 187.50/m²

incl. power supply rated at 6 kW, consumption and pre-show cleaning

You can use our practical online aid on the Internet at www.standconfigurator.com to visualize the shape, color and equipment of **your** personal exhibition stand. We will be pleased to advise you personally:

Tel +49 (0) 9 11. 86 06-80 00 or
messeservice@nuernbergmesse.de

Additional services, special equipment and individual requirements are obtainable on request and can be ordered overleaf.

Text for lettering on fascia:

<input type="text"/>	<input type="text"/>	<input type="text"/>	<input type="text"/>	<input type="text"/>	<input type="text"/>	<input type="text"/>	<input type="text"/>	<input type="text"/>	<input type="text"/>	<input type="text"/>	<input type="text"/>	<input type="text"/>	<input type="text"/>	<input type="text"/>	<input type="text"/>	<input type="text"/>	<input type="text"/>	<input type="text"/>	<input type="text"/>
<input type="text"/>	<input type="text"/>	<input type="text"/>	<input type="text"/>	<input type="text"/>	<input type="text"/>	<input type="text"/>	<input type="text"/>	<input type="text"/>	<input type="text"/>	<input type="text"/>	<input type="text"/>	<input type="text"/>	<input type="text"/>	<input type="text"/>	<input type="text"/>	<input type="text"/>	<input type="text"/>	<input type="text"/>	<input type="text"/>

Orders received later than 14 days before the start of the event will be billed an express surcharge of 25 %, subject to a minimum surcharge of EUR 10 per order.

Yes, we order daily cleaning during the exhibition at a total extra price of EUR 1.65/m².

All prices stated are subject to the addition of **VAT at the statutory rate** and **3 % insurance premium**.

* If necessary, NürnbergMesse is entitled to have the service ordered provided by another ServicePartner. In this case, the customer will be notified of the other ServicePartner in good time.

With our authorized signature below, we acknowledge acceptance of all items of the General and Special Terms of Business of NürnbergMesse and the General Terms of Business and the Special Conditions for Services of the ServicePartner.

We do not require insurance and accept liability for the stand and rented objects.

Place and date

Company stamp and authorized signature

Additional equipment Complete rental stand SATURN

Order

1. Exclusive variations

1.1 Floor covering (at extra cost per m²):

Velours

- wine red EUR 5.25
- blue EUR 5.25
- gray EUR 5.25
- slate EUR 5.25

Laminate

with false floor, 63 mm, (chipboard) and aluminum profiles

- Polar oak longstrip wood floor EUR 30.60
- Maple plank longstrip wood floor EUR 30.60
- Walnut patchwood longstrip wood floor EUR 30.60
- Oak Cappuccino 1-strip flooring EUR 30.60
- Canadian spruce 2-strip plank flooring EUR 30.60

1.2 Visuals (2 items):

complete visuals back-lit

- integrated full size banner, back-lit, including full digital print EUR 224.50
- colored acrylic glass on request

Exhibitor must provide print data 20 days before the event.

1.3 Stand furniture:

1.4 Additional furniture (each):

Lounge chair "Dado"

- EUR 104.00

Side table "Stylus"

- EUR 50.00

Info counter "Slide"

- EUR 122.70

Bar stool "Cube"

- EUR 51.00

Lounge furniture "High Chair"

anthracite, upholstery fabric

- EUR 280.00

Side table "Tria"

(0.57 x 0.50 m x 0.37 m) chromium frame, top white

- EUR 75.00

1.5 Additional lighting (each):

Extending spotlight

- 130 W, energy saver EUR 39.00

Floral stand decoration – see Online ExhibitorShop under Stand Construction – Floral stand decoration / landscaping services.

Exclusive and additional equipment can be seen in the stand configurator at **www.standconfigurator.com**. Additional stand equipment can be found at **www.mesomondo.de**.

All prices

are subject to the addition of VAT at the statutory rate and 3 % insurance premium for stand material and furniture.

- We do not require insurance and accept liability for damage and loss.

Services on request

The following hourly flat rates are charged plus VAT at the statutory rate:

1. Working hour at EUR 49.50

The organizer is responsible for assembling and dismantling the SATURN complete rental stand.

The complete rental stand and its equipment must not be pasted over, nailed, painted or damaged in any other way.

The exhibitor is liable for damage caused during the rental period and will be charged with the costs.

Remarks: _____



Orders received later than 14 days before the start of the event will be billed an express surcharge of 25 %, subject to a minimum surcharge of EUR 10 per order. With our authorized signature below, we acknowledge acceptance of all items of the General and Special Terms of Business of NürnbergMesse and the General Terms of Business and the Special Conditions for Services of the ServicePartner.

Place and date _____

Company stamp and authorized signature _____

Complete rental stand SUN

S0.99

Nuremberg, Germany
14-16.3.2017



embeddedworld2017

Exhibition & Conference
... it's a smarter world

Return to
NürnbergMesse GmbH
MesseService
Messezentrum
90471 Nürnberg
Tel +49 (0) 9 11. 86 06-80 00
Fax +49 (0) 9 11. 86 06-80 01
messeservice@nuernbergmesse.de

Contractor *
:mesomondo GmbH
Messezentrum 1
90471 Nürnberg
Tel +49 (0) 9 11. 40 08 35-0
Fax +49 (0) 9 11. 40 08 35-29
info@mesomondo.de
www.mesomondo.de

Company

Street

Postcode, Town, Country

Tel

Fax

E-mail

Return deadline
14.12.2016

Hall/Stand

Person to contact

Tel

Fax

Invoice address (only if different)

Order

Stand type (Please enclose plan):



in-line stand



corner stand



head stand



block stand

Stand size: front _____ m x depth _____ m **minimum size: 28 m²**

The rental for the duration of the event includes the following equipment:

Walls

custom made wall panels, white, 2.70 m and 3.00 m high, on all closed sides of the stand space (no modular material visible)

Floor covering

including protective plastic covering, edging tape and disposal; with false floor (chipboard) and aluminum profiles

Velour carpet anthracite or:

blue gray red

Cubicle

size according to stand space; with lockable door

Functional units

graphic panel 0.90 x 2.00 m; fixed to the light pylon; suitable for lettering or printing

Light box

0.80 x 0.80 x 0.10 m; on the open sides of the stand space; suitable for lettering or printing

Lettering

in Helvetica medium black; please enter text in "Remarks" box on the right.

1 glass table "Tonda"

Silver base with glass top; 0.60 m diameter

4 chairs "Breeze", black or:

red blue white

1 counter "Soltau"

1.70 x 0.75 x 1.13 m; lockable with shelves; back-lit in white

1 bar stool "Breeze", black or:

red blue white

1 leaflet stand

with 6 compartments for DIN A4

1 shelving unit

with 4 shelves 0.82 m wide; 0.30 m deep; illuminated from above; sides in gray or:

red blue

Nepro spotlight

130 W, 1 spotlight for each full 4 m² stand space; fixed to electric tracks on the light pylon

Power supply

in the cubicle, rated at 6 kW (AC), including consumption and 3-way mains socket.

Power rating increased from 6 kW to 9 kW (AC) surcharge EUR 180.50

Power supply of more than 9 kW – see Online ExhibitorShop under Technical Services – Electricity supply. (PDF Form S2.10)

NEW! Including pre-show cleaning

before the start of the exhibition, including removing and disposal of carpet dust sheet.

VAT ID number of exhibitor:

<input type="text"/>	<input type="text"/>	<input type="text"/>	<input type="text"/>	<input type="text"/>	<input type="text"/>	<input type="text"/>	<input type="text"/>	<input type="text"/>	<input type="text"/>	<input type="text"/>	<input type="text"/>	<input type="text"/>	<input type="text"/>	<input type="text"/>	<input type="text"/>	<input type="text"/>	<input type="text"/>	<input type="text"/>	<input type="text"/>
----------------------	----------------------	----------------------	----------------------	----------------------	----------------------	----------------------	----------------------	----------------------	----------------------	----------------------	----------------------	----------------------	----------------------	----------------------	----------------------	----------------------	----------------------	----------------------	----------------------



Complete price EUR 232.50/m²
incl. power supply rated at 6 kW, consumption and pre-show cleaning

You can use our practical online aid on the Internet at www.standconfigurator.com to visualize the shape, color and equipment of **your** personal exhibition stand. We will be pleased to advise you personally:

Tel +49 (0) 9 11. 86 06-80 00 or
messeservice@nuernbergmesse.de

Additional services, special equipment and individual requirements are obtainable on request and can be ordered overleaf.

Text for lettering on fascia:

<input type="text"/>	<input type="text"/>	<input type="text"/>	<input type="text"/>	<input type="text"/>	<input type="text"/>	<input type="text"/>	<input type="text"/>	<input type="text"/>	<input type="text"/>	<input type="text"/>	<input type="text"/>	<input type="text"/>	<input type="text"/>	<input type="text"/>	<input type="text"/>	<input type="text"/>	<input type="text"/>	<input type="text"/>	<input type="text"/>
----------------------	----------------------	----------------------	----------------------	----------------------	----------------------	----------------------	----------------------	----------------------	----------------------	----------------------	----------------------	----------------------	----------------------	----------------------	----------------------	----------------------	----------------------	----------------------	----------------------

<input type="text"/>	<input type="text"/>	<input type="text"/>	<input type="text"/>	<input type="text"/>	<input type="text"/>	<input type="text"/>	<input type="text"/>	<input type="text"/>	<input type="text"/>	<input type="text"/>	<input type="text"/>	<input type="text"/>	<input type="text"/>	<input type="text"/>	<input type="text"/>	<input type="text"/>	<input type="text"/>	<input type="text"/>	<input type="text"/>
----------------------	----------------------	----------------------	----------------------	----------------------	----------------------	----------------------	----------------------	----------------------	----------------------	----------------------	----------------------	----------------------	----------------------	----------------------	----------------------	----------------------	----------------------	----------------------	----------------------

Orders received later than 14 days before the start of the event will be billed an express surcharge of 25 %, subject to a minimum surcharge of EUR 10 per order.

Yes, we order daily cleaning during the exhibition at a total extra price of EUR 1.65/m².

All prices stated are subject to the addition of **VAT at the statutory rate** and **3 % insurance premium**.

* If necessary, NürnbergMesse is entitled to have the service ordered provided by another ServicePartner. In this case, the customer will be notified of the other ServicePartner in good time.

With our authorized signature below, we acknowledge acceptance of all items of the General and Special Terms of Business of NürnbergMesse and the General Terms of Business and the Special Conditions for Services of the ServicePartner.

We do not require insurance and accept liability for the stand and rented objects.

Place and date

Company stamp and authorized signature

Additional equipment Complete rental stand SUN

Order

1. Additional stand equipment

1.1 Cubicle:

Larger cubicle

- additional space on request

1.2 Flooring Laminate (per m²)

- Polar oak longstrip
wood floor EUR 15.70
- Maple plank longstrip
wood floo EUR 15.70
- Walnut patchwood longstrip
wood floor EUR 15.70
- Oak Cappuccino
1-strip flooring EUR 15.70
- Canadian spruce
2-strip plank flooring EUR 15.70

1.3 Additional furniture (each):

Glass table "Tonda"

with chrome base, 0.60 m diameter

- EUR 73.50

Chair "Breeze"

- white EUR 32.00
- blue EUR 32.00
- black EUR 32.00
- red EUR 32.00

Bar stool "Breeze"

- white EUR 44.00
- blue EUR 44.00
- black EUR 44.00
- red EUR 44.00

Leaflet stand

as on first page

- EUR 51.00

Shelving unit

as on first page

- on request

Counter

as on first page

- EUR 367.90

1.4 Lighting (each):

Extra spotlight

130 watts

- EUR 39.00

Floral stand decoration – see Online ExhibitorShop under Stand Construction – Floral stand decoration / landscaping services.

Exclusive and additional equipment can be seen in the stand configurator at **www.standconfigurator.com**. Additional stand equipment can be found at **www.mesomondo.de**.

All prices

are subject to the addition of VAT at the statutory rate and 3 % insurance premium for stand material and furniture.

- We do not require insurance and accept liability for damage and loss.

Services on request

The following hourly flat rates are charged plus VAT at the statutory rate:

1. Working hour at EUR 49.50

The organizer is responsible for assembling and dismantling the SUN complete rental stand.

The complete rental stand and its equipment must not be pasted over, nailed, painted or damaged in any other way.

The exhibitor is liable for damage caused during the rental period and will be charged with the costs.

Remarks: _____

Orders received later than 14 days before the start of the event will be billed an express surcharge of 25 %, subject to a minimum surcharge of EUR 10 per order. With our authorized signature below, we acknowledge acceptance of all items of the General and Special Terms of Business of NürnbergMesse and the General Terms of Business and the Special Conditions for Services of the ServicePartner.

Nuremberg, Germany
14–16.3.2017



embeddedworld2017

Exhibition&Conference
... it's a smarter world

Return to
NürnbergMesse GmbH
MesseService
Messezentrum
90471 Nürnberg
Tel +49 (0) 9 11. 86 06-80 00
Fax +49 (0) 9 11. 86 06-80 01
messe-service@nuernbergmesse.de

Contractor *
:mesomondo GmbH
Messezentrum 1
90471 Nürnberg
Tel +49 (0) 9 11. 40 08 35-0
Fax +49 (0) 9 11. 40 08 35-29
info@mesomondo.de
www.mesomondo.de

Company _____

Street _____

Postcode, Town, Country _____

Tel _____

Fax _____

E-mail _____

Return deadline
14.12.2016

Hall/Stand _____

Person to contact _____

Tel _____

Fax _____

Invoice address (only if different) _____





Order (Special Conditions for Services overleaf)

Stand space (please complete in full)

The size of the stand space to be equipped is:

front: _____ m **depth:** _____ m

Please tick as appropriate and enclose plan. The plan can be obtained in the Online ExhibitorShop under Stand Construction – Stand partition walls. (PDF Form S1.45)

-  in-line stand 1 side open
-  corner stand 2 sides open (right)
-  corner stand 2 sides open (left)
-  head stand 3 sides open
-  block stand 4 sides open

VAT ID number of exhibitor:

4 chairs, anthracite or:

- white red blue olive
- 1 sitting area for every full 12 m² stand space

1 table: round, diameter 70 cm or: square, 70 x 70 cm, with center stand

1 waste paper basket

1 coat rack

The rental for the stated rental stand is:

EUR 120.80/m² (from 20 m² stand space).

Electrical equipment

Spotlights can be ordered in the Online ExhibitorShop under Stand Construction – Extra stand equipment / floor coverings / furniture – Stand equipment (contractor: :mesomondo GmbH).

A power supply can be ordered in the Online ExhibitorShop under Technical Services – Electricity supply. (PDF Form S2.10)

Equipment for rental stand COONS

Standard equipment (tick as applicable)

Velour carpet, anthracite or:

- light gray red blue green

Walls

single-skin walls, no system elements visible, white, 2.50 m height

Cubicle

1.00 x 2.00 m, lockable door

Lettering: 3 x DIN A4 logos attached to wall

Lighting: extending spotlight, 1 x 130 watt spotlight for every full 3 m²

Furniture

1 counter: Slide



* If necessary, NürnbergMesse is entitled to have the service ordered provided by another ServicePartner. In this case, the customer will be notified of the other ServicePartner in good time.

With our authorized signature below, we acknowledge acceptance of all items of the General and Special Terms of Business of NürnbergMesse and the General Terms of Business and the Special Conditions for Services of the ServicePartner.

Place and date

Company stamp and authorized signature

We will be pleased to advise you on the individual design of your stand.

Can be extended with information counter, product display units and shelves on request (at extra charge). Please order in the Online Exhibitor-Shop under Stand Construction – Extra stand equipment / floor coverings / furniture – Stand equipment (contractor: :mesomondo GmbH).
(PDF Forms S1.60 – S1.62)

Additional stand equipment:

www.mesomondo.de



Special Conditions for Services provided by :mesomondo GmbH

Messezentrum 1, 90471 Nürnberg
Tel +49 (0) 9 11. 40 08 35-0
Fax +49 (0) 9 11. 40 08 35-29
info@mesomondo.de, www.mesomondo.de

Rental conditions

1. Unless otherwise stated, the rental charge is calculated for the duration of the event and is due for payment in full immediately on receipt of the invoice.
2. Unless otherwise stated, all items listed are available for rental only. The rental goods are not suitable for use outdoors.
3. The price quoted includes delivery, assembly and dismantling.
4. Reductions in the price per m² cannot be considered for any deduction in services requested by the exhibitor.
5. Missing or damaged rental goods will be charged at the cost of replacement. The exhibitor's liability for stand elements and furniture commences on delivery and ceases on collection by the ServicePartner (even if exhibitor has already left the stand), up to a maximum of 24 hours after the end of event.
6. Please note: The following surcharges will be made for orders and orders with incomplete information received less than 14 days before the start of the event:
Services at fixed prices (e.g. furniture ...) 25 %
Hourly work (e.g. modifications ...) 50 %.

With our authorized signature below, we acknowledge acceptance of all items of the General and Special Terms of Business of NürnbergMesse and the General Terms of Business and the Special Conditions for Services of the ServicePartner.

7. Exhibitors wishing to cancel orders must notify the ServicePartner :mesomondo in writing at least 10 days before the start of event, otherwise the full rental charge will be invoiced.
8. All prices are subject to the addition of VAT at the statutory rate.
9. Foreign exhibitors not settling invoices in cash will be debited with any bank charges incurred. International cheques, credit cards and credit transfer from outside the EUR (€) area will be charged with EUR 16.50.
10. A processing fee of EUR 50 plus VAT at the statutory rate will be charged for issuing a new invoice due to incorrect information provided by the applicant. This fee will be included in the new invoice issued.
11. The place of fulfillment and jurisdiction for both parties, including debt collection proceedings, is Nürnberg.
12. **The stand holder is liable for any damage caused by inappropriate handling of walls and fascias, for example, screwing, nailing and use of strong adhesives.**
13. This order form also acts as the contract to supply goods, unless cancelled by us.

Services and orders made as part of the Last Minute Service are due for payment immediately.

► Important! Please note:

The stand elements and rental furniture are to be insured by the ServicePartner :mesomondo. The insurance premium amounts to 3 % of the rental charge and will be invoiced in addition.

- We do not require insurance and assume responsibility for all damage and losses in accordance with the above rental conditions.

Fitters hourly rate

The following hourly flat rates are charged plus VAT at the statutory rate:

1. Working hour at EUR 49.50

Payment by credit card

- We wish to pay by credit card:

Issuer: MasterCard American Express
 VISA Diners Club

Card no.: _____ / _____ / _____

Card verification no.: (The last 3 digits next to the signature on the back of the card or for AMEX 4 digits on the front)

--	--	--	--

Valid until: _____

Holder of card: _____

Nuremberg, Germany
14-16.3.2017



embeddedworld2017

Exhibition&Conference
... it's a smarter world

Return to
NürnbergMesse GmbH
MesseService
Messezentrum
90471 Nürnberg
Tel +49 (0) 9 11. 86 06-80 00
Fax +49 (0) 9 11. 86 06-80 01
messeservice@nuernbergmesse.de

Contractor *
Holtmann GmbH & Co. KG
Messezentrum
90471 Nürnberg
Tel +49 (0) 9 11. 86 06-60 50
Fax +49 (0) 9 11. 86 06-60 59
info@holtmann.de
www.holtmann.de

Company _____

Street _____
Postcode, Town, Country _____
Tel _____
Fax _____
E-mail _____

Return deadline
14.12.2016

Hall/Stand

Person to contact _____
Tel _____
Fax _____
Invoice address (only if different) _____

Enquiry

High-quality fair stands implemented by HOLTSMANN





Holtmann offers architecture systems for individual design and configuration or as fully equipped stands. Always your advantage – the exclusive service. We advise you in all questions of your fair concept, develop your stand design and then professionally implement your project.

Stand space (please complete in full)

The size of the stand space to be equipped is:

front: _____ m depth: _____ m

Please tick as appropriate and enclose plan. The plan can be obtained in the Online ExhibitorShop under Stand Construction – Stand partition walls. (PDF Form S1.45)

-  in-line stand 1 side open
-  corner stand 2 sides open (right)
-  corner stand 2 sides open (left)
-  head stand 3 sides open
-  block stand 4 sides open

VAT ID number of exhibitor:

Please note the following details:

Floor covering

Carpet Laminate Other: _____

Function rooms

Kitchen
Fittings: _____

 Store room/cloakroom
Fittings: _____

 Other: _____

Conference/meeting rooms

Number _____ Size _____ m²

Open seating areas

Standing tables: Number _____ Tables: Number _____

Other features

Info/reception counters Catering/refreshment counters
 Showcases: Number _____ Podiums: Number _____
 Media technology: _____
 Digital prints: _____

Customer-own exhibits

Number: ____ Dimensions: Length _____ x Width _____ x Height _____

Your company's color details/CD colors: _____

Other requirements: _____

* If necessary, NürnbergMesse is entitled to have the service ordered provided by another ServicePartner. In this case, the customer will be notified of the other ServicePartner in good time.

With our authorized signature below, we acknowledge acceptance of all items of the General and Special Terms of Business of NürnbergMesse and the General Terms of Business and the Special Conditions for Services of the ServicePartner.

Place and date _____

Company stamp and authorized signature _____

Basic illustration:



7. Exhibitors wishing to cancel orders must notify the ServicePartner Holtmann GmbH & Co. KG in writing at least 10 days before the start of event, otherwise the full rental charge will be invoiced.
8. All prices are subject to the addition of VAT at the statutory rate.
9. Foreign exhibitors not settling invoices in cash will be debited with any bank charges incurred. International cheques, credit cards and credit transfer from outside the EUR (€) area will be charged with EUR 16.50.
10. A processing fee of EUR 50 plus VAT at the statutory rate will be charged for issuing a new invoice due to incorrect information provided by the applicant. This fee will be included in the new invoice issued.
11. The place of fulfillment and jurisdiction for both parties, including debt collection proceedings, is Nurnberg.
12. **The stand holder is liable for any damage caused by inappropriate handling of walls and fascias, for example, screwing, nailing and use of strong adhesives.**
13. This order form also acts as the contract to supply goods, unless cancelled by us.

Services and orders made as part of the Last Minute Service are due for payment immediately.

► **Important! Please note:**

The stand elements and rental furniture are to be insured by the ServicePartner Holtmann GmbH & Co. KG. The insurance premium amounts to 3 % of the rental charge and will be invoiced in addition.

- We do not require insurance and assume responsibility for all damage and losses in accordance with the above rental conditions.

Special Conditions for Services provided by Holtmann GmbH & Co. KG

Messezentrum, 90471 Nürnberg
Tel +49 (0) 9 11. 86 06-60 55
info@holtmann.de, www.holtmann.de

Rental conditions

1. Unless otherwise stated, the rental charge is calculated for the duration of the event and is due for payment in full immediately on receipt of the invoice.
2. Unless otherwise stated, all items listed are available for rental only. The rental goods are not suitable for use outdoors.
3. The price quoted includes delivery, assembly and dismantling.
4. Reductions in the price per m² cannot be considered for any deduction in services requested by the exhibitor.
5. Missing or damaged rental goods will be charged at the cost of replacement. The exhibitor's liability for stand elements and furniture commences on delivery and ceases on collection by the ServicePartner (even if exhibitor has already left the stand), up to a maximum of 24 hours after the end of event.
6. Please note: The following surcharges will be made for orders and orders with incomplete information received less than 14 days before the start of the event:

Services at fixed prices (e.g. furniture ...)	25 %
Hourly work (e.g. modifications ...)	50 %.

Fitters hourly rate

The following hourly flat rates are charged plus VAT at the statutory rate:

1. Direction hour at EUR 49.50



With our authorized signature below, we acknowledge acceptance of all items of the General and Special Terms of Business of NürnbergMesse and the General Terms of Business and the Special Conditions for Services of the ServicePartner.

Place and date

Company stamp and authorized signature

Presentation with pep: Stylish not standard!



Individuality guarantees success. You are only noticed and remembered if you are different. We therefore design an unusual stand for you, a stand that highlights your company, your philosophy and your products in a credible and exciting way.

In short: An individual stand that guarantees you a successful exhibition.

We implement, plan and design your ideas with you. With our some 30 partners, we offer advice and genuine full service – for a really successful presentation.

Have we aroused your interest? If so, please fill in the questionnaire overleaf and fax to Exhibition Services.

Nuremberg, Germany
14–16.3.2017



embeddedworld2017

Exhibition&Conference
... it's a smarter world

Return to
NürnbergMesse GmbH
MesseService
Messezentrum
90471 Nürnberg
Tel +49 (0) 9 11. 86 06-80 00
Fax +49 (0) 9 11. 86 06-80 01
messeservice@nuernbergmesse.de

Return deadline **Hall/Stand**
immediately

Company _____

Street _____
Postcode, Town, Country _____
Tel _____
Fax _____
E-mail _____

Person to contact _____
Tel _____
Fax _____
Internet _____

1. At what other exhibition(s) do you exhibit?

4. What products and/or services will you offer?

2. What is your reason for exhibiting?

(Please indicate order of priority if you tick more than one box)

Customer care
 Image care
 Gaining new contacts
 Exchanging views
 Gaining new customers
 Sales transactions
 Presentation of new products
 Observation of competition
 General information about your products
 Other: _____

5. What colors, shapes and logos would you like for your stand?

6. What and how many exhibits will you present at the exhibition?

(Please state dimensions)

7. What advertising materials (brochures, flyers, graphics, media, etc.) will you bring with you?

3. What is your budget for stand construction and exhibition presentation?

(in EUR)

8. What did you particularly like or dislike the last time you exhibited – especially in terms of stand construction?

This is only initial information for us. We will be pleased to discuss further details with you personally.

Your Exhibition Services Team

Nuremberg, Germany
14-16.3.2017

Return to
 NürnbergMesse GmbH
 MesseService
 Messezentrum
 90471 Nürnberg
 Tel +49 (0) 9 11. 86 06-80 00
Fax +49 (0) 9 11. 86 06-80 01
 messeservice@nuernbergmesse.de

Company stamp:



embeddedworld2017
 Exhibition&Conference
 ... it's a smarter world

Hall/Stand

Please draw your plan accurately to avoid misunderstandings.

Please enter the required article numbers on the plan.

Key:

- Partition wall
- ⊗ Spotlight
- - - Fascia
- ~ ~ ~ Lettering
- ┌——— Door

Scale (please tick as applicable) 1:200 1:100 1:50

Nuremberg, Germany
14-16.3.2017



Return to
NürnbergMesse GmbH
MesseService
Messezentrum
90471 Nürnberg
Tel +49 (0) 9 11. 86 06-80 00
Fax +49 (0) 9 11. 86 06-80 01
messe-service@nuernbergmesse.de

Contractor *
Furniture sets 1 – 4
Fa. Messebau Wörnlein GmbH

Furniture sets 5 – 24
Fa. Hummel Möbelverleih GmbH

Company _____

Street _____
Postcode, Town, Country _____
Tel _____
Fax _____
E-mail _____

Return deadline _____
14.12.2016

Hall/Stand _____

Person to contact _____
Tel _____
Fax _____
Invoice address (only if different) _____

Order

VAT ID number of exhibitor:

Description	Quantity	EUR
<p>1. Set of table and chairs "m.o.d."</p> <p><input type="checkbox"/> Set with 3 chairs <input type="checkbox"/> Set with 4 chairs</p>  <p>Table "Rondo" Height: 0.70 m; Ø 0.70 m Frame: chrome; top: anthracite Designer chair "m.o.d." Finish: gray, frame: silver effect</p>		151.50 188.50
<p>2. PC table with bar stool "Z"</p>  <p>PC table Width: 0.70 m, depth: 0.50 m Overall height: 1.05 m White top with black rounded edge and built-in mains sockets. Base column (aluminum) with HDMI and network cables inside.</p> <p><input type="checkbox"/> With bar stool "Z" Height: 0.90 m Upholstery: <input type="checkbox"/> black or <input type="checkbox"/> white</p>		166.50

Description	Quantity	EUR
<p>3. <input type="checkbox"/> Bar counter "U"</p>  <p>1.18 x 0.55 x 1.09 m light gray base unit, lockable doors, all-round aluminum support, shelf at top 0.30 m deep <input type="checkbox"/> front and top shelf glossy red <input type="checkbox"/> front and top shelf glossy anthracite <input type="checkbox"/> Bar counter "U" with bar stool "Coma" Chrome/black, height 0.75 m</p>		299.00 343.50
<p>4. Set "Romeo"</p> <p><input type="checkbox"/> Set with 2 leather armchair and 1 side table <input type="checkbox"/> Set with 4 leather armchair and 2 side tables</p> 		173.00 323.00







ServicePartner for furniture sets 1 – 4:
Messebau Wörnlein GmbH
Messezentrum
90471 Nürnberg
Tel +49 (0) 9 11. 81 74 49-0
Fax +49 (0) 9 11. 81 74 49-25
info@woernlein.de
www.woernlein.de

Orders received later than 14 days before the start of the event will be billed an express surcharge of 25 %, subject to a minimum surcharge of EUR 10 per order.
All prices stated are subject to the addition of **VAT at the statutory rate** and **3 % insurance premium.**
* If necessary, NürnbergMesse is entitled to have the service ordered provided by another ServicePartner. In this case, the customer will be notified of the other ServicePartner in good time.
With our authorized signature below, we acknowledge acceptance of all items of the General and Special Terms of Business of NürnbergMesse and the Special Conditions for Services for furniture sets.
 We do not require insurance and accept liability for the rented objects on this form.

Place and date

Company stamp and authorized signature

Order (continued)

Description	Quantity	EUR	Description	Quantity	EUR
<p>5. Furniture set "Pocket"</p> <p><input type="checkbox"/> Set with 3 chairs <input type="checkbox"/> Set with 4 chairs</p>  <p>Chair "Pocket", gray metal frame, plastic seat and back <input type="checkbox"/> blue <input type="checkbox"/> white <input type="checkbox"/> charcoal gray</p> <p>Round table, matt-finish chromium frame, white top, Ø 0.80/0.75 m high</p>		80,50 94,50	<p>8. Furniture set "Gliss"</p> <p><input type="checkbox"/> Set with 3 chairs <input type="checkbox"/> Set with 4 chairs</p>  <p>Chair "Gliss", chromium frame, polypropylene seat shell <input type="checkbox"/> white <input type="checkbox"/> black <input type="checkbox"/> red</p> <p>Round table, matt-finish chromium frame, white top, Ø 0.80/0.75 m high</p>		152,50 190,50
<p>6. Furniture set "Bonni white"</p> <p><input type="checkbox"/> Set with 3 chairs <input type="checkbox"/> Set with 4 chairs</p>  <p>Chair "Bonni", plastic seat and back, white</p> <p>Round table "Tonda" white top, 0.80 m</p>		85,00 100,50	<p>9. Furniture set "Breeze"</p> <p><input type="checkbox"/> Set with 3 chairs <input type="checkbox"/> Set with 4 chairs</p>  <p>Chair "Breeze" <input type="checkbox"/> white <input type="checkbox"/> black <input type="checkbox"/> red <input type="checkbox"/> blue <input type="checkbox"/> gray</p> <p>Table "Sea", round, Ø 0.80 m, Frame polished aluminum, 0.73 m high White top</p>		151,00 183,00
<p>7. Furniture set "Bonni"</p> <p><input type="checkbox"/> Set with 3 chairs <input type="checkbox"/> Set with 4 chairs</p>  <p>Upholstered chair "Bonni" <input type="checkbox"/> black <input type="checkbox"/> red <input type="checkbox"/> blue</p> <p>Matt chrome table, white top, Ø 0.80/0.75 m high</p>		103,00 124,50	<p>10. Furniture set "Catifa"</p> <p><input type="checkbox"/> Set with 3 chairs <input type="checkbox"/> Set with 4 chairs</p>  <p>Chair "Catifa", chromium frame, white plastic seat and back</p> <p>Round table "Inox", matt-finish chromium frame, white top, Ø 0.80/0.74 m high</p>		144.50 179.50

Orders received later than 14 days before the start of the event will be billed an express surcharge of 25 %, subject to a minimum surcharge of EUR 10 per order.
All prices stated are subject to the addition of **VAT at the statutory rate** and 3 % **insurance premium**.

* If necessary, NürnbergMesse is entitled to have the service ordered provided by another ServicePartner. In this case, the customer will be notified of the other ServicePartner in good time.







With our authorized signature below, we acknowledge acceptance of all items of the General and Special Terms of Business of NürnbergMesse and the Special Conditions for Services for furniture sets.

We do not require insurance and accept liability for the rented objects on this form.

Place and date

Company stamp and authorized signature

Order (continued)

Description	Quantity	EUR	Bezeichnung	Anzahl	EUR
<p>11. Furniture set chair "Kuadra"</p> <p><input type="checkbox"/> Set with 3 chairs <input type="checkbox"/> Set with 4 chairs</p>  <p>Chair "Kuadra", matt chromium frame plastic seat and back <input type="checkbox"/> white <input type="checkbox"/> red Round table "Tonda" white top, 0.80 m</p>		122.50 150.50	<p>14. Furniture set bar stool "Kicca"</p> <p><input type="checkbox"/> Set with 2 bar stools <input type="checkbox"/> Set with 3 bar stools</p>  <p>Bar stool "Kicca", chromium frame, plastic seat and back <input type="checkbox"/> white <input type="checkbox"/> black <input type="checkbox"/> anthracite</p>		155.50 204.50
<p>12. Furniture set bar stool "Kuadra"</p> <p><input type="checkbox"/> Set with 2 bar stools <input type="checkbox"/> Set with 3 bar stools</p>  <p>Bar stool "Kuadra", matt chromium frame white plastic seat and back High table "Tonda" round, white top, 0.60 m</p>		135.50 174.50	<p>15. Furniture set chair "Tweet"</p> <p><input type="checkbox"/> Set with 3 chairs <input type="checkbox"/> Set with 4 chairs</p>  <p>Chair "Tweet", matt chromium frame, combination of color <input type="checkbox"/> white/black <input type="checkbox"/> white/gray <input type="checkbox"/> white/orange <input type="checkbox"/> white/green <input type="checkbox"/> white/red Table, matt chromium frame, Ø 0.80 m/0.75 m high, white top</p>		131.50 162.50
<p>13. Set "Kicca"</p> <p><input type="checkbox"/> Set with 3 chairs <input type="checkbox"/> Set with 4 chairs</p>  <p>Chair "Kicca", chromium frame, plastic seat and back <input type="checkbox"/> white <input type="checkbox"/> black <input type="checkbox"/> anthracite</p>		131.50 162.50	<p>16. Furniture set bar stool "Tweet"</p> <p><input type="checkbox"/> Set with 2 bar stools <input type="checkbox"/> Set with 3 bar stools</p>  <p>Bar stool "Tweet", matt chromium frame, combination of color <input type="checkbox"/> white/black <input type="checkbox"/> white/gray <input type="checkbox"/> white/orange <input type="checkbox"/> white/green <input type="checkbox"/> white/red High table, matt chromium frame, round</p>		145.50 189.50

Orders received later than 14 days before the start of the event will be billed an express surcharge of 25 %, subject to a minimum surcharge of EUR 10 per order. All prices stated are subject to the addition of VAT at the statutory rate and 3 % insurance premium.

* If necessary, NürnbergMesse is entitled to have the service ordered provided by another ServicePartner. In this case, the customer will be notified of the other ServicePartner in good time.





With our authorized signature below, we acknowledge acceptance of all items of the General and Special Terms of Business of NürnbergMesse and the Special Conditions for Services for furniture sets.

We do not require insurance and accept liability for the rented objects on this form.

Place and date

Company stamp and authorized signature

Order (continued)

Description	Quantity	EUR	Description	Quantity	EUR
<p>17. Furniture set "Beech"</p> <p><input type="checkbox"/> Set with 2 bar stools <input type="checkbox"/> Set with 3 bar stools</p>  <p>Bar stool "Z", chromium frame, seat in natural beech Round table, matt-finish chromium frame, natural beech top, Ø 0.60/1.14 m high</p>		117.50 142.50	<p>20. Furniture set "Toledo 130 and 170"</p> <p><input type="checkbox"/> Toledo 130, white 4 x bar stool "Cube" 1 x high table "Toledo" white, 1.30/0.60/1.10 m</p>  <p><input type="checkbox"/> Toledo 170, white 6 x bar stool "Cube" 1 x high table "Toledo" white, 1.70/0.60/1.10 m</p> 		324.00 436.00
<p>18. Furniture set "Cube"</p> <p><input type="checkbox"/> Set with 2 bar stools <input type="checkbox"/> Set with 3 bar stools</p>  <p>Bar stool "Cube" and high table "Inox", top 0.60/0.60 m <input type="checkbox"/> white <input type="checkbox"/> black</p>		159.50 210.50	<p>21. Furniture set "Bar"</p> <p><input type="checkbox"/> Set with 2 bar stools <input type="checkbox"/> Set with 3 bar stools</p>  <p>Bar counter "Syma New", aluminum profile, white panel, 1.00 x 0.50 x 1.25 m Bar stool "Z", black</p>		167.00 192.00
<p>19. Furniture set "Lem"</p> <p><input type="checkbox"/> Set with 2 bar stools <input type="checkbox"/> Set with 3 bar stools</p>  <p>Bar stool "Lem" <input type="checkbox"/> white <input type="checkbox"/> black <input type="checkbox"/> beech <input type="checkbox"/> nut Round standing table, matt chromium frame Top "Inox", Ø 0.60/1.14 m high <input type="checkbox"/> white <input type="checkbox"/> black</p>		201.50 273.50	<p>22. Furniture set cube chair "Ben"</p> <p><input type="checkbox"/> Set with 3 cube chairs <input type="checkbox"/> Set with 4 cube chairs</p>  <p>Cube chair "Ben", synthetic leather <input type="checkbox"/> white <input type="checkbox"/> black Side table "Tria", matt-finished chromium frame, 0.57 x 0.50 m, 0.37 m high <input type="checkbox"/> white <input type="checkbox"/> black</p>		150.00 175.00

Orders received later than 14 days before the start of the event will be billed an express surcharge of 25 %, subject to a minimum surcharge of EUR 10 per order. All prices stated are subject to the addition of VAT at the statutory rate and 3 % insurance premium.

* If necessary, NürnbergMesse is entitled to have the service ordered provided by another ServicePartner. In this case, the customer will be notified of the other ServicePartner in good time.



With our authorized signature below, we acknowledge acceptance of all items of the General and Special Terms of Business of NürnbergMesse and the Special Conditions for Services for furniture sets.

We do not require insurance and accept liability for the reted objects on this form.

Place and date _____

Company stamp and authorized signature _____

Order (continued)

Description	Quantity	EUR
<p>23. Furniture set lounge "Host-Modular" <input type="checkbox"/> 1 x 2-seater and side table <input type="checkbox"/> 1 x 2-seater and 2 x 1-seater and side table</p>  <p>1- or 2-seater "Host-Modular", matt-finished chromium frame, upholstery synthetic leather <input type="checkbox"/> white <input type="checkbox"/> black Side table "Tria", matt-finished chromium frame, 0.57 x 0.50 m, 0.37 m high Top <input type="checkbox"/> white <input type="checkbox"/> black</p>		<p>205.00 403.00</p>
<p>24. Furniture set lounge "Qubo" <input type="checkbox"/> 2 x 1-seater and side table "Tria" <input type="checkbox"/> 2 x 1-seater and 1 x 2-seater and side table "Tria"</p>  <p>1- or 2-seater "Qubo", matt-finished chromium frame, Polster upholstery synthetic leather <input type="checkbox"/> white <input type="checkbox"/> black Side table "Tria", matt-finished chromium frame, 0.57 x 0.50 m, 0.37 m high Top <input type="checkbox"/> white <input type="checkbox"/> black</p>		<p>271.00 449.00</p>

ServicePartner for furniture sets 5 – 24:

Hummel Möbelverleih GmbH
 Messezentrum
 90471 Nürnberg
Tel +49 (0) 9 11. 86 06-63 03
Fax +49 (0) 9 11. 86 06-63 04
 nuernberg@hummel-mietmoebel.de
 www.hummel-mietmoebel.de

Special Conditions for Services for furniture sets

Rental conditions

- The rental object is only made available for the agreed purpose and for the agreed period. An extension of the rental period shall require the written consent of the rental company. The rental company is entitled to invoice an additional rental charge if the rental object is not returned by the agreed time.
- The rental prices are calculated according to the duration of rental on the basis of the currently valid price list. The statutory VAT is to be added. For objects rented for a trade fair or exhibition the rental prices shall also include the costs for delivery and collection of the rental object within the exhibition grounds. Invoiced rental prices are payable net. Direct orders directly before and during a trade fair are to be paid on award of the order.
- For loss or damage of the rental object compensation amounting to the cost of replacement may be claimed from the renter or the cost of repair if this does not exceed the replacement value. Liability shall commence with the takeover of the rental object by the renter and end with its collection by the rental company. In the case of objects rented for a trade fair, liability shall commence with delivery to the exhibition stand and end when it is collected from there. This shall also apply if the exhibition stand is not occupied. Liability shall end 24 hours after the end of the trade fair at the latest unless the rental object was not made available for collection or another collection date has been agreed. The rental company shall not be liable for damage to property or injury to persons in connection with the use of the rental object unless it is due to wilful action or gross negligence on the part of the rental company.
- The rental object is not insured. Insurance of the rental object for the period of a trade fair, including the stand construction and dismantling period, is recommended.
Important:
All rental furniture will be insured by NürnbergMesse GmbH. The premium is equal to 3 % of the rental price and will be charged separately to the hiring party.
 We do not require insurance and acknowledge our liability as set forth in the rental terms contained herein.
- All orders with no specified date will be delivered in good time so that the rental object is available at the start of the fair. After the end of the fair the rental object will be collected as quickly as possible. The renter must make the rental object available for collection. If delivery or collection of the rental object is prevented by fault of the renter, the rental company shall be entitled to charge for any additional expenditure incurred. In the event of default of payment the rental company reserves the right to refuse delivery of the rental object or to fetch back delivered objects at an earlier date.
- Rental objects ordered in advance and reserved but not taken delivery of will be charged to the customer in full. If it is possible to rent them elsewhere the customer shall bear the costs incurred for delivery and collection and for any loss of rental fees.
 In cases of unforeseeable damage the rental company reserves the right to supply equivalent or better replacement objects in place of the ordered rental objects. No claims can be asserted as a result of such replacements.
- All the stated items are only provided for rental.
- Any complaints the renter may have must be made within 24 hours of the items concerned having been delivered. Any complaints made after this time will not be accepted.
- Place of performance and jurisdiction for the renter and rental company shall be the registered office of the rental company. The laws of the Federal Republic of Germany shall apply even for transactions with foreign customers.

Rental of extra stand equipment, floor coverings and furniture

S1.60

Nuremberg, Germany
14–16.3.2017



embeddedworld2017

Exhibition&Conference

... it's a smarter world

Return to
NürnbergMesse GmbH
MesseService
Messezentrum
90471 Nürnberg
Tel +49 (0) 9 11. 86 06-80 00
Fax +49 (0) 9 11. 86 06-80 01
messe-service@nuernbergmesse.de

Contractor *
:mesomondo GmbH
Messezentrum 1
90471 Nürnberg
Tel +49 (0) 9 11. 40 08 35-0
Fax +49 (0) 9 11. 40 08 35-29
info@mesomondo.de
www.mesomondo.de

Return deadline
14.12.2016

Hall/Stand

Company

Street

Postcode, Town, Country

Tel

Fax

E-mail

Person to contact

Tel

Fax

Invoice address (only if different)

Order: for Special Conditions for Services have a look at the Online ExhibitorShop under Stand Construction – Extra stand equipment / floor coverings / furniture – Stand equipment (contractor: :mesomondo GmbH). (PDF Form S1.62)

VAT ID number of exhibitor:



The idea makes the difference

- Stands
- Furniture Rental
- Digital Printing
- Exhibition Services

**meso
mondo**
MESSESERVICES





* If necessary, NürnbergMesse is entitled to have the service ordered provided by another ServicePartner. In this case, the customer will be notified of the other ServicePartner in good time.

With our authorized signature below, we acknowledge acceptance of all items of the General and Special Terms of Business of NürnbergMesse and the General Terms of Business and the Special Conditions for Services of the ServicePartner.

Place and date

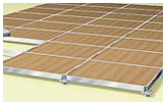

Company stamp and authorized signature



Order: Floor coverings

Equipment	Description	m Qty. m ²	EUR
	1. <input type="checkbox"/> Raised floor , with laying boards, 120 mm high with, aluminum edging, without floor covering. Ideal for laying cables, pipes or water connections under the floor	m ²	34.40
	2. Ribbed carpet in rolls , brand-new, disposable goods, including laying, disposal and dust sheet <input type="checkbox"/> light gray <input type="checkbox"/> anthracite <input type="checkbox"/> blue <input type="checkbox"/> red Other colors on request <input type="checkbox"/> up to 50 m ² <input type="checkbox"/> > 50 m ²	m ² m ²	9.80 on request
	3. Velour , carpet in rolls, brand-new, disposable goods, including laying, disposal and dust sheet <input type="checkbox"/> gray <input type="checkbox"/> anthracite <input type="checkbox"/> blue <input type="checkbox"/> beige <input type="checkbox"/> brown <input type="checkbox"/> red <input type="checkbox"/> green Other colors on request <input type="checkbox"/> up to 50 m ² <input type="checkbox"/> > 50 m ²	m ² m ²	14.30 on request
	4. Laminate , laid on chipboard, including aluminum edging strip <input type="checkbox"/> Polar oak longstrip wood floor <input type="checkbox"/> Maple plank longstrip wood floor <input type="checkbox"/> Walnut patchwood longstrip wood floor <input type="checkbox"/> Oak Cappuccino 1-strip flooring <input type="checkbox"/> Canadian spruce 2-strip plank flooring <input type="checkbox"/> up to 50 m ² <input type="checkbox"/> > 50 m ²	m ² m ²	34.90 on request



Please note our terms and conditions stated on order form S1.62 paragraph 12!

Walls and doors

	5. Syma system wall element , aluminum frame construction, grid size 990 mm, height 2485 mm <input type="checkbox"/> plain panel, single-sided white m <input type="checkbox"/> perforated panel, single-sided white m <input type="checkbox"/> plain panel, double-sided white m <input type="checkbox"/> perforated panel, double-sided white m <input type="checkbox"/> surcharge for panel in trend colors per side of wall m <input type="checkbox"/> Slatted wall element professional presentation of your products. white m <input type="checkbox"/> Wall increasement (1.00 m) total height 3.50 m price per element singel-sided white m double-sided white m singel-sided trend colors m	m m m m m m m m m m	32.50 32.10 42.20 42.20 67.20 154.60 25.60 33.80 53.90
	6. Syma Segment wall , 3 segments, grid size 990 mm, height 2485 mm <input type="checkbox"/> white m <input type="checkbox"/> gray m <input type="checkbox"/> trend colors m <input type="checkbox"/> transparent glass m	m m m m	65.80 71.90 79.00 85.00

Equipment	Description	m Qty. m ²	EUR
	7. Wall cladding , without visible supports, height 2500 mm, (surcharge) <input type="checkbox"/> white m <input type="checkbox"/> gray m <input type="checkbox"/> trend colors m <input type="checkbox"/> Mounting wall white surface, height 2.485 m inner measure 0.96 m, thickness 19 mm to be used for mounting of exhibitor goods, plasmas e.g. (for purchase) each	m m m each	32.00 on request on request 103.00
	8. Curtain for cubicle, entrance width 960 mm <input type="checkbox"/> white each	each	32.50
	9. <input type="checkbox"/> Hinged door , white, DIN R each <input type="checkbox"/> Hinged door , white, DIN L each	each each	78.00 78.00



Ceilings and fascias

	10. Slide-in fascia , lattice support <input type="checkbox"/> blue <input type="checkbox"/> white <input type="checkbox"/> gray <input type="checkbox"/> green <input type="checkbox"/> yellow <input type="checkbox"/> red m	m	16.00
	11. <input type="checkbox"/> Lattice support , natural aluminum m Graphic carrier for lattice support with or without slide-in fascia <input type="checkbox"/> Dolphin fascia . approx. 1.50 x 0.70 m each	m each	11.60 67.10

Lightning

12. Lightning <input type="checkbox"/> Extending spotlight each <input type="checkbox"/> HQI spotlight each	each each	39.00 93.30
--	--------------	----------------

Shelves and product presentation



	13. <input type="checkbox"/> Shelf, max. load 8 kg , 990 x 300 mm, white, please indicate position and height! m <input type="checkbox"/> special sizes <input type="checkbox"/> glass shelves	m	20.40 on request 35.70
	14. <input type="checkbox"/> Sloping shelf White, e.g. for DIN A4 leaflets, please indicate position and height! m	m	30.50

With our authorized signature below, we acknowledge acceptance of all items of the General and Special Terms of Business of NürnbergMesse and the General Terms of Business and the Special Conditions for Services of the ServicePartner.

Place and date

Company stamp and authorized signature

Shelves and product presentation (Continued)

Equipment	Description	m Qty. m ²	EUR
	15. <input type="checkbox"/> "DIALOG" shelf Side-wall design with 5 shelves (center shelf not adjustable) color: aluminum silver each		122.80
	16. <input type="checkbox"/> Slatted wall display Facing elements for our system wall for professional presentation of your products. Size 960 x 1020 mm, light gray m		154.60

Showcases

Illuminated showcases incl. 5 m extension cable. **Attention:** Please contact your stand construction company or SAG (Form S2.10) if you need a longer cable.

	17. <input type="checkbox"/> Showcase, 4-piece, system 3000 Top with lighting, glass top unit with 1 glass shelf and sliding doors, closed bottom unit with 2 sliding doors and 1 shelf, plinth, overall size 920 x 520 mm, height 2050 mm, lockable sliding doors each <input type="checkbox"/> Glass shelf each <input type="checkbox"/> Safety socket 230 V, layed on the wished place of your stand space St.		220.80 29.10 20.00
	18. <input type="checkbox"/> Showcase, 4-piece, system 3000 Top with lighting, glass top and bottom unit with total of 2 glass shelves, 1 shelf, lockable sliding doors, overall size 920 x 520 mm, height 2050 mm, please indicate exact position! each <input type="checkbox"/> Glass shelf each <input type="checkbox"/> Safety socket 230 V, layed on the wished place of your stand space St.		265.00 29.10 20.00
	19. <input type="checkbox"/> "Box" showcase Silver body, lockable and illuminated 500 x 500 mm, height 2100 mm, showcase size 465 x 465 x 890 mm each <input type="checkbox"/> Safety socket 230 V, layed on the wished place of your stand space St.		201.00 20.00
	20. <input type="checkbox"/> Platform showcase bottom unit white, lockable, 0.50 x 0.50 x 1.05 m, including glass top unit: 0.47 x 0.47 x 0.50 m each		204.00

Equipment	Description	m Qty. m ²	EUR
	21. Table showcase, 2-piece, system 3000 bottom unit: white, lockable overall size 920 x 520 mm, height 1030/1100 mm <input type="checkbox"/> Glass top unit 180 mm each <input type="checkbox"/> Glass top unit 250 mm each		125.50 128.50

Counters and sideboards



	22. <input type="checkbox"/> Information counter, system 3000 white, 1 shelf, open back, not lockable, white plinth, overall size 920 x 520 mm, height 1080 mm each <input type="checkbox"/> in special colors RAL each		83.00 on request
	23. <input type="checkbox"/> Counter, system 3000 White, 1 shelf, lockable sliding doors, white base, overall size 920 x 520 mm, height 1080 mm each		96.00
	24. <input type="checkbox"/> Counter "Item" white, backside open, top gray, one blue LED-strip, (1000 x 520 x 1020 mm – W/D/H) each <input type="checkbox"/> Safety socket 230 V, layed on the wished place of your stand space each		100.00 20.00
	25. <input type="checkbox"/> Counter "Barcelona" white, lockable, (1100 x 600 x 1100 mm – W/D/H) each		183.60
	26. <input type="checkbox"/> Counter "Madrid" white, lockable, (1700 x 600 x 1100 mm – W/D/H) each		285.60
	27. <input type="checkbox"/> Counter "SLIM" Front segmented, white acryl glass, 1 shelf, lockable, overall size 700 x 600, height 1100 mm each		144.20
	28. Counter "SLIDE" Segmented body, exchangeable panels, 1 shelf, lockable, overall size 990 x 500 x 1100 mm Basic element: 1000 mm <input type="checkbox"/> white each fashion colors <input type="checkbox"/> blue <input type="checkbox"/> red <input type="checkbox"/> yellow <input type="checkbox"/> green <input type="checkbox"/> gray each Basic element: 2000 mm <input type="checkbox"/> white each fashion colors <input type="checkbox"/> blue <input type="checkbox"/> red <input type="checkbox"/> yellow <input type="checkbox"/> green <input type="checkbox"/> gray each		122.70 130.50 216.00 248.10

With our authorized signature below, we acknowledge acceptance of all items of the General and Special Terms of Business of NürnbergMesse and the General Terms of Business and the Special Conditions for Services of the ServicePartner.

Place and date _____



Company stamp and authorized signature _____

Order: Counters and sideboards (Continued)



Equipment	Description	m Qty. m ²	EUR
	29. <input type="checkbox"/> Sideboard, system 3000 White, 1 shelf, lockable sliding doors, overall size 920 x 520 mm, height 850 mm each		70.90
	30. <input type="checkbox"/> Base cupboard, Frame construction, 1 shelf, lockable sliding doors, overall size 990 x 495, height 750 mm each		80.20

Chairs

Lounge furniture in various sizes and colors on request



	31. "FAKT" with armrest Plastic upholstered chair, chrome frame with shell and upholstery each <input type="checkbox"/> light gray/gray <input type="checkbox"/> dark gray/gray <input type="checkbox"/> blue/gray <input type="checkbox"/> black/black		23.60
	32. "FAKT" Plastic upholstered chair, chrome frame with shell and upholstery each <input type="checkbox"/> light gray/gray <input type="checkbox"/> dark gray/gray <input type="checkbox"/> blue/gray <input type="checkbox"/> black/black		21.20
	33. "JO" Plastic chair each <input type="checkbox"/> white <input type="checkbox"/> ivory <input type="checkbox"/> brown <input type="checkbox"/> olive <input type="checkbox"/> red <input type="checkbox"/> blue <input type="checkbox"/> anthracite		25.60
	34. <input type="checkbox"/> "JOERG" Chair with beech seat, chrome frame each		27.70

Bar stools

	35. Bar stool "ZETA" Upholstered each <input type="checkbox"/> white upholstery <input type="checkbox"/> black upholstery		25.00
	36. <input type="checkbox"/> Bar stool "LEM" chrome frame, matt finish, height-adjustable, white each		73.00

Further chairs/office chairs on request

Tables

Equipment	Description	m Qty. m ²	EUR
	37. Square table Overall size 700 x 700 mm, height 750 mm <input type="checkbox"/> white <input type="checkbox"/> beech each each		27.00 29.30
	38. Rectangular table Overall size 700 x 1200 mm, height 750 mm <input type="checkbox"/> white <input type="checkbox"/> beech each each		33.00 39.70
	39. Round table Diameter 700 mm, height 750 mm <input type="checkbox"/> white <input type="checkbox"/> beech each each		37.50 39.80
	40. Round standing table Diameter 700 mm, height 1100 mm <input type="checkbox"/> white <input type="checkbox"/> beech each each		44.90 48.10

PC tables and media furniture

	41. <input type="checkbox"/> "BOX" PC table, size 500 x 500 mm, height 1100 mm, silver body, lockable, keyboard shelf and top: beech each		144.50
	<input type="checkbox"/> Safety socket 230 V, layed on the wished place of your stand space St.		20.00

Platforms

	42. Platforms , max. load 50 kg, height 750 mm, top always white <input type="checkbox"/> 490 x 970 mm, sides white each <input type="checkbox"/> 490 x 970 mm, sides in trend colors each <input type="checkbox"/> blue <input type="checkbox"/> red <input type="checkbox"/> yellow <input type="checkbox"/> green <input type="checkbox"/> gray <input type="checkbox"/> 970 x 970 mm, sides white each <input type="checkbox"/> 970 x 970 mm, sides in trend colors each <input type="checkbox"/> blue <input type="checkbox"/> red <input type="checkbox"/> yellow <input type="checkbox"/> green <input type="checkbox"/> gray <input type="checkbox"/> special colors and versions		33.50 62.20 46.00 74.30 on request
---	---	--	--

Leaflet stands

	43. <input type="checkbox"/> Leaflet stand "SLAT" Height 1340 mm, 4 shelves each		57.70
---	--	--	-------

With our authorized signature below, we acknowledge acceptance of all items of the General and Special Terms of Business of NürnbergMesse and the General Terms of Business and the Special Conditions for Services of the ServicePartner.

Place and date

Company stamp and authorized signature

Order: Coat racks (Continued)

Equipment	Description	m Qty. m ²	EUR
	44. <input type="checkbox"/> Coat rack With 5 hooks, width 900 mm each		19.90

Kitchen equipment

	45. <input type="checkbox"/> Refrigerator 140 l, overall size 600 x 600 mm, height 850 mm each		69.90
	46. <input type="checkbox"/> Plastic kitchen shelf unit 4 shelves, overall size 870 x 430 mm, height 1800 mm each		40.50
	47. <input type="checkbox"/> Waste bin with 3 bags each		20.30
	48. <input type="checkbox"/> Waste paper basket each		9.10

Fitters hourly rate

The following hourly flat rates are charged plus VAT at the statutory rate:

- Working hour at EUR 49.50

Special Conditions for Services provided by :mesomondo GmbH

Messezentrum 1, 90471 Nürnberg
Tel +49 (0) 9 11. 40 08 35-0
Fax +49 (0) 9 11. 40 08 35-29
info@mesomondo.de, www.mesomondo.de

Rental conditions

- Unless otherwise stated, the rental charge is calculated for the duration of the event and is due for payment in full immediately on receipt of the invoice.
- Unless otherwise stated, all items listed are available for rental only. The rental goods are not suitable for use outdoors.
- The price quoted includes delivery, assembly and dismantling.
- Reductions in the price per m² cannot be considered for any deduction in services requested by the exhibitor.

With our authorized signature below, we acknowledge acceptance of all items of the General and Special Terms of Business of NürnbergMesse and the General Terms of Business and the Special Conditions for Services of the ServicePartner.

Place and date _____

- Missing or damaged rental goods will be charged at the cost of replacement. The exhibitor's liability for stand elements and furniture commences on delivery and ceases on collection by the ServicePartner (even if exhibitor has already left the stand), up to a maximum of 24 hours after the end of event.
- Please note: The following surcharges will be made for orders and orders with incomplete information received less than 14 days before the start of the event:
Services at fixed prices (e.g. furniture ...) 25 %
hourly work (e.g. modifications ...) 50 %.
- Exhibitors wishing to cancel orders must notify the ServicePartner in writing at least 10 days before the start of event, otherwise the full rental charge will be invoiced.
- All prices are subject to the addition of VAT at the statutory rate.
- Foreign exhibitors not settling invoices in cash will be debited with any bank charges incurred. International checks, credit cards and credit transfer from outside the EUR (€)-area will be charged with EUR 16.50.
- A processing fee of EUR 50 plus VAT at the statutory rate will be charged for issuing a new invoice due to incorrect information provided by the applicant. This fee will be included in the new invoice issued.
- The place of fulfillment and jurisdiction for both parties, including debt collection proceedings, is Nürnberg.
- The stand holder is liable for any damage caused by inappropriate handling of walls and fascias, for example, screwing, nailing and use of strong adhesives.**
The use of screws, nails or adhesive tapes is not allowed.
We must charge you for any damaged, soiled or stuck stand material.
To clean adhesives from our rental equipment we have to charge you the costs listed below:
- Wall panel EUR 19.00 each, net
- Support EUR 18.00 each, net
- Frame EUR 15.00 each, net
- This order form also acts as the contract to supply goods, unless cancelled by us.

Services and orders made as part of the Last Minute Service are due for payment immediately.

► **Please note:**

The stand elements and rental furniture are to be insured by the ServicePartner. The insurance premium amounts to 3 % of the rental charge and will be invoiced in addition.

- We do not require insurance and assume responsibility for all damage and losses in accordance with the above rental conditions.

Payment by credit card

- We wish to pay by credit card:

Issuer: MasterCard American Express
 VISA Diners Club

Card no.: _____ / _____ / _____

Card verification no.: (The last 3 digits next to the signature on the back of the card or for AMEX 4 digits on the front)

--	--	--	--

Valid until: _____

Holder of card: _____

Company stamp and authorized signature _____

Rental of extra stand equipment, floor coverings and furniture

S1.64

Nuremberg, Germany
14–16.3.2017



embeddedworld2017

Exhibition&Conference

... it's a smarter world

Return to
NürnbergMesse GmbH
MesseService
Messezentrum
90471 Nürnberg
Tel +49 (0) 9 11. 86 06-80 00
Fax +49 (0) 9 11. 86 06-80 01
messe-service@nuernbergmesse.de

Contractor *
Messebau Wörnlein GmbH
Messezentrum
90471 Nürnberg
Tel +49 (0) 9 11. 81 74 49-0
Fax +49 (0) 9 11. 81 74 49-25
info@woernlein.de
www.woernlein.de

Return deadline
14.12.2016

Hall/Stand

Company

Street

Postcode, Town, Country

Tel

Fax

E-mail

Person to contact

Tel

Fax

Invoice address (only if different)

Order: for Special Conditions for Services have a look at the Online ExhibitorShop under Stand Construction – Extra stand equipment / floor coverings / furniture – Stand equipment (contractor: Messebau Wörnlein GmbH). (PDF Form S1.66)

The extra stand equipment and rental furniture available for your stand can be seen on the following pages.

VAT ID number of exhibitor:

Please indicate the desired article numbers and quantities, if possible on your plan of the stand, the plan can be obtained in the Online ExhibitorShop under Stand Construction – Stand partition walls. (PDF Form S1.45)

Erfolg
reiche
Z e i t
Räume



Trade fair.
Effective use of
time and space.

Creative stand construction
System stand
Rental furniture & Accessoires

 messebau
wörnlein



* If necessary, NürnbergMesse is entitled to have the service ordered provided by another ServicePartner. In this case, the customer will be notified of the other ServicePartner in good time.



With our authorized signature below, we acknowledge acceptance of all items of the General and Special Terms of Business of NürnbergMesse and the General Terms of Business and the Special Conditions for Services of the ServicePartner.

Place and date

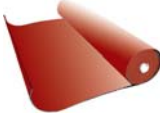
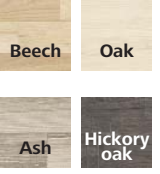

Company stamp and authorized signature

Order: Floor coverings



Equipment	Description	Qty./m/m²	EUR
	1. Art. Carpet , in rolls, new, including disposal and dust sheet		
	<input type="checkbox"/> Felt carpet , colors: m²	9.50	
	<input type="checkbox"/> Ribbed carpet , colors: m²	9.80	
	<input type="checkbox"/> other colors and qualities		on request
	2. Art. a) Laminate , from 24 m², including sub-structure and aluminium border		34.25
	b) Digital print on flooring: Vinyl flooring, 2mm, B1, individual price incl. laying, removal and disposal		
	<input type="checkbox"/> from 10 m² m²	57.90	
	<input type="checkbox"/> from 30 m² m²	54.90	
	<input type="checkbox"/> from 50 m² m²	48.90	

Equipment	Description	Qty./m/m²	EUR
	6. Art. Screen wall element (in addition to the system wall)		
	a) Height: 2.55 m		
	<input type="checkbox"/> white, thickness 19 mm each		69.20
	<input type="checkbox"/> light gray, thickness 19 mm each		69.20
	<input type="checkbox"/> MDF (medium density fibreboard) abrasive, non-painted, thickness 16 mm each		76.30
	b) Height: 3.55 m		
	<input type="checkbox"/> white, thickness 19 mm each		102.10
	<input type="checkbox"/> light gray, thickness 19 mm each		102.10
	<input type="checkbox"/> MDF (medium density fibreboard) abrasive, non-painted, thickness 16 mm each		109.90
	7. Art. <input type="checkbox"/> Cubicle curtain each		32.50
	height: 2.20 m, width: 1.00 m		
	<input type="checkbox"/> gray <input type="checkbox"/> blue		
	<input type="checkbox"/> black <input type="checkbox"/> red		
	please indicate position on plan		
	8. Art. Light column 2.50 m high, segment-shaped curved acryl glass, back-lit, approx. 1.00 m wide, free-standing arrangement possible.		
	<input type="checkbox"/> without digital printing each		288.50
	<input type="checkbox"/> with digital printing on one side each		445.50
	<input type="checkbox"/> with digital printing on both sides each		599.50
	Print data are provided by the customer in each case.		
	Light column 4.00 m high, as above		
	<input type="checkbox"/> without digital printing each		427.50
	<input type="checkbox"/> with digital printing on one side each		654.50
	<input type="checkbox"/> with digital printing on both sides each		884.50
	<input type="checkbox"/> 1-way power point each		34.50
	Installed at the required location on the stand (only possible with stand assembly conducted by Wörnlein). If you are working with another stand assembly firm, please inform them or SAG GmbH about the power point required for the light column/order it from them.		

Wall elements, doors, curtains

	3. Art. Wall element with metal frame height: 2.50 m, width: 1.00 m (also available in widths: 0.25/0.35/0.50/0.70 m)		
	a) Wall element , meroform (chrome/steel)		
	<input type="checkbox"/> plastic-coated, matt white each		32.50
	<input type="checkbox"/> perforated board, white each		34.30
	<input type="checkbox"/> plastic-coated, black each		46.90
	<input type="checkbox"/> other colors		on request
	b) Wall extension of 1 m, meroform, at additional costs, plain		
	<input type="checkbox"/> plastic-coated, matt white each		27.00
	<input type="checkbox"/> plastic-coated, black each		38.30
	c) Door meroform		
	<input type="checkbox"/> hinged door, white each		78.00
	<input type="checkbox"/> hinged door, other colors		on request
	<input type="checkbox"/> folding door, white each		105.60
	4. Art. a) Wall elements Syma (Alu)		
	<input type="checkbox"/> plastic coated, matt white each		32.50
	<input type="checkbox"/> perforated board, white each		34.30
	b) Wall elements, Syma		
	<input type="checkbox"/> hinged door, white each		78.00
	5. Art. a) Wall element , Axiom system, white		
	<input type="checkbox"/> plastic-coated, matt white each		32.15
	b) Door , Axiom system		
	<input type="checkbox"/> hinged door, white each		78.00
	<input type="checkbox"/> folding door, white each		105.60

Painting, fabrics, digital printing

	9. Art. Painted MDF board, including acrylization	m²	17.25
	<input type="checkbox"/> please state RAL no.: _____ or enclose color sample!		
	10. Art. <input type="checkbox"/> Decorative fabric	m	8.50
	various colors on request width: 1.30 m flame-retardant impregnation		
	<input type="checkbox"/> Decorative fabric	m²	14.10
	including fitting to wall element, removal and disposal		
	11. Art. <input type="checkbox"/> Digital printing	m²	38.30
	on 140–190 g paper, color print		
	* Digital print on self-adhesive foil		
	<input type="checkbox"/> excluding assembly	m²	52.00
	<input type="checkbox"/> including assembly	m²	73.50

* Please have a look at the Online ExhibitorShop under **Stand Construction – Fascias and Lettering** (contractor: Messebau Wörnlein GmbH). (PDF Form S1.71)

With our authorized signature below, we acknowledge acceptance of all items of the General and Special Terms of Business of NürnbergMesse and the General Terms of Business and the Special Conditions for Services of the ServicePartner.



Place and date _____

Company stamp and authorized signature _____





Order: Digital printing (continued)

Equipment	Description	Qty./m/m²	EUR
* Please have a look at the Online ExhibitorShop under Stand Construction - Fascias and lettering (contractor: Messebau Wörnlein GmbH). (PDF Form S1.71)	* Digital printing on textile (single-sided) ready-to-use, indoors/outdoors		
	<input type="checkbox"/> with kedar profile on top and base, up to 5 m²	m²	88.50
	<input type="checkbox"/> over 5 m²	m²	80.50
	<input type="checkbox"/> textile banners, white, semi-transparent, ready-to-use, incl. kedar profile rail, incl. installation and dismantling	m²	53.00

Fascias, supports

	12. Art. <input type="checkbox"/> Fascia , plastic-coated, height: 0.30 m <input type="checkbox"/> white (similar to RAL 9010) <input type="checkbox"/> blue (similar to RAL 5017) <input type="checkbox"/> yellow (similar to RAL 1023) <input type="checkbox"/> brown (similar to RAL 8014) <input type="checkbox"/> Special color similar to RAL no.: _____ or enclosed color sample <input type="checkbox"/> other versions and sizes	m	16.00
	<input type="checkbox"/> Light fascia 1.50 m x 0.50 m, 0.09 m, aluminum frame with LED edge illumination, incl. digital printing on fabric (print data are provided by the customer)	each	190.00
	13. Art. <input type="checkbox"/> Cross strut , chrome/steel (in connection with fascia)	m	9.50



System constructions

	14. Art. System construction adapted to the chosen wall element (Mero/Syma) <input type="checkbox"/> Lattice support <input type="checkbox"/> Support <input type="checkbox"/> Reinforced corner support	m each each	11.60 9.50 35.10
	15. Art. <input type="checkbox"/> Mero ceiling 1.00 x 1.00 m height: 0.70 m; chrome/steel	m²	22.95
	16. Art. <input type="checkbox"/> Quadro lattice support 0.25 m/0.25 m chrome/steel	m	28.75
	17. Art. Module crossbars <input type="checkbox"/> Q125 aluminum, 12.5/12.5 cm <input type="checkbox"/> Q91 aluminum, 9.1/9.1 cm	m m	35.10 31.00

Equipment	Description	Qty./m/m²	EUR
	18. Art. <input type="checkbox"/> Lattice fabric , flame-retardant and suitable for use below sprinklers, excluding fitting	m²	19.00
	<input type="checkbox"/> Fabric canopy of lattice fabric, flame-retardant and suitable for sprinklers, ready-for-use, white for Mero lattice ceiling and Quadro lattice supports	m²	29.15

Lighting



Please order electricity supply separately.

	19. Art. Spotlights , plug-in, individually adjustable <input type="checkbox"/> halogen (150 watts) each <input type="checkbox"/> halogen (300 watts) each <input type="checkbox"/> halogen, "Collus" (130 watts) each <input type="checkbox"/> HQI, silver (150 watts) each		37.20 73.20 39.00 72.60
	Spotlights for power rail , minimum of 2 per rail (2.00 m) <input type="checkbox"/> "Lightspot", silver (100 watts) each <input type="checkbox"/> "Domos", silver (150 watts) each high-voltage with 3-phase adaptor		39.20 44.80

Shelves

	20. Art. Shelves for various systems (as chosen wall element – Axiom, Syma, Mero or standard wall element) Shelf 30 depth: 0.30 m <input type="checkbox"/> white <input type="checkbox"/> beech <input type="checkbox"/> silver <input type="checkbox"/> glass Shelf 50 depth: 0.50 m <input type="checkbox"/> white <input type="checkbox"/> glass Shelf, sloping with lip depth: 0.30 m <input type="checkbox"/> white <input type="checkbox"/> other colors	each each each each each each each	20.40 21.00 36.60 22.00 38.20 22.00 on request
---	--	--	--

Sideboards









	21. Art. <input type="checkbox"/> Sideboard Syma, lockable width: 0.98 m, depth: 0.50 m overall height: 0.72 m corpus: white, 1 shelf, sliding doors	each	74.40
	22. Art. <input type="checkbox"/> Sideboard, Mero, lockable width: 1.05 m, depth: 0.55 m, overall height: 0.75 m corpus: white 1 shelf	each	74.40

With our authorized signature below, we acknowledge acceptance of all items of the General and Special Terms of Business of NürnbergMesse and the General Terms of Business and the Special Conditions for Services of the ServicePartner.

Place and date

Company stamp and authorized signature





Order: Counters (continued)

Equipment	Description	Qty./m/m ²	EUR
	23. Art. <input type="checkbox"/> Counter Syma, lockable each width: 0.98 m, depth: 0.50 m overall height: 1.12 m corpus: white 1 shelf, sliding doors		96.90
	24. Art. <input type="checkbox"/> Counter Mero, open back each width: 1.05 m, depth: 0.55 m, overall height: 1.05 m, 1 shelf <input type="checkbox"/> white <input type="checkbox"/> beech		83.00 127.30
	25. Art. <input type="checkbox"/> Theke Mero, lockable each width: 1.05 m, depth: 0.55 m, overall height: 1.05 m white		96.00
	26. Art. <input type="checkbox"/> Info counter Mero, lockable each width: 1.05 m, depth: 0.55 m height of raised top: 0.25 m overall height: 1.25 m, 1 shelf, backside lockable white		98.50
	27. Art. <input type="checkbox"/> Info counter Mero with curved raised top each width: 1.05 m, depth: 0.55 m; overall height: 1.10 m top: approximately 1.60 x 0.40 m; color of main unit: <input type="checkbox"/> white <input type="checkbox"/> anthracite color of top: <input type="checkbox"/> blue <input type="checkbox"/> red <input type="checkbox"/> beech		155.00
	28. Art. <input type="checkbox"/> Counter "Circle" each gray, door at back, silver front with back-lit acryl glass strips: <input type="checkbox"/> red <input type="checkbox"/> blue <input type="checkbox"/> green <input type="checkbox"/> white glass top, width 1.50 m, depth: 0.60 m, overall height: 1.10 m <input type="checkbox"/> other widths <input type="checkbox"/> 1-way power point each Installed at the required location on the stand (only possible with stand assembly conducted by Wörnlein). If you are working with another stand assembly firm, please inform them or SAG GmbH about the power point required for the counter/order it from them.		305.80 on request 34.80
	29. Art. <input type="checkbox"/> Counter "Wave" each corpus light gray, door at back, width: 1.05 m, depth: 0.55 m, overall height: 1.05 m, front color: <input type="checkbox"/> aluminum wave <input type="checkbox"/> Wengé		152.80
	30. Art. <input type="checkbox"/> Counter "Cube" each corpus gray, back side 1/2 open, 1/2 lockable, width: 2.33 m, depth: 0.60 m, height: 1.10 m, clip afloat 0.40 m deep: <input type="checkbox"/> red <input type="checkbox"/> blue <input type="checkbox"/> basalt gray		407.80
	31. Art. <input type="checkbox"/> Counter "high tech" each corpus aluminum, open back, width: 1.00 m, depth 0.55 m, height 1.10 m, raised shelf, color of shelf: <input type="checkbox"/> red <input type="checkbox"/> blue <input type="checkbox"/> black		202.90

Equipment	Description	Qty./m/m ²	EUR
	32. Art. <input type="checkbox"/> Counter "Unit" each white body, back-lit acryl glass front panel, 1.25 x 0.64 m, h = 1.15 m <input type="checkbox"/> Corner element "Unit" , white body, back-lit acryl glass front panel, 0.77 x 0.77 m, h = 1.15 m each <input type="checkbox"/> 1-way power point each Installed at the required location on the stand (only possible with stand assembly conducted by Wörnlein). If you are working with another stand assembly firm, please inform them or SAG GmbH about the power point required for the counter/order it from them.		313.70 265.00 34.80

All counters can be extended or fitted around corners on request.

Showcases

	33. Art. <input type="checkbox"/> Table showcase Mero base unit open , width: 1.05 m, depth: 0.55 m, overall height: 1.05 m; glass case: 0.35 m, lockable, without lighting	each	77.00
	34. Art. <input type="checkbox"/> Table showcase Mero, base unit , width: 1.05 m, depth: 0.55 m, overall height: 1.05 m; glass case: 0.35 m, lockable, without lighting; base unit: with lockable doors: corpus white <input type="checkbox"/> Table showcase Syma, with base unit , width: 1.05 m, depth: 0.55 m, overall height: 1.05 m; glass case: 0.35 m, lockable, base unit: with sliding door, lockable <input type="checkbox"/> LED lighting for table showcase Syma each <input type="checkbox"/> 1-way power point each Installed at the required location on the stand (only possible with stand assembly conducted by Wörnlein). If you are working with another stand assembly firm, please inform them or SAG GmbH about the power point required for the showcase/order it from them.	each each	128.50 128.50 60.20 34.80
	35. Art. <input type="checkbox"/> Showcase lean, with base unit , width: 0.50 m, each depth: 0.50 m, aluminum, base unit: closed, overall height: 1.88 m; aluminum frame with glass, lockable, with 3 glass shelves and light. <input type="checkbox"/> Extra glass shelf each <input type="checkbox"/> 1-way power point each Installed at the required location on the stand (only possible with stand assembly conducted by Wörnlein). If you are working with another stand assembly firm, please inform them or SAG GmbH about the power point required for the showcase/order it from them.	each each	227.50 18.00 34.80
	36. Art. <input type="checkbox"/> Showcase broad, fully glazed each width: 1.00 m, depth: 0.55 m, overall height: 1.88 m, lockable, aluminum frame with glass, with 3 glass shelves and light. <input type="checkbox"/> Extra glass shelf each <input type="checkbox"/> 1-way power point each Installed at the required location on the stand (only possible with stand assembly conducted by Wörnlein). If you are working with another stand assembly firm, please inform them or SAG GmbH about the power point required for the showcase/order it from them.	each each	265.00 23.30 34.80

With our authorized signature below, we acknowledge acceptance of all items of the General and Special Terms of Business of NürnbergMesse and the General Terms of Business and the Special Conditions for Services of the ServicePartner.

Place and date



Company stamp and authorized signature

Order: Showcases (continued)

Equipment	Description	Qty./m/m²	EUR
	37. Art. <input type="checkbox"/> Showcase lean, fully glazed each width: 0.52 m, depth: 0.55 m, overall height: 1.88 m, lockable, aluminum frame with glass, with 3 glass shelves and light <input type="checkbox"/> Extra glass shelf each <input type="checkbox"/> 1-way power point each Installed at the required location on the stand (only possible with stand assembly conducted by Wörnlein). If you are working with another stand assembly firm, please inform them or SAG GmbH about the power point required for the showcase/order it from them.		220.30 18.00 34.80

The meroform system offers unlimited scope for imagination. A great variety of individual platforms, cubes, towers and lattices can be constructed in a wide range of shapes, colors and materials. Please contact us.

PC furniture



	38. Art. <input type="checkbox"/> PC furniture "Design" S each corpus (W x D) 0.75 m x 0.44 m, height: 1.07 m, corpus lockable, frame light gray with filling silver perforated top oval 1.20 m x 0.60 m with cable outlet: <input type="checkbox"/> beech <input type="checkbox"/> light gray <input type="checkbox"/> blue <input type="checkbox"/> red <input type="checkbox"/> 1-way power point each Installed at the required location on the stand (only possible with stand assembly conducted by Wörnlein). If you are working with another stand assembly firm, please inform them or SAG GmbH about the power point required for the PC furniture/order it from them.		163.20 34.80
	<input type="checkbox"/> PC furniture "Design" S+ each as "Design" S, top oval, red with top part, light gray, 1.40 x 0.80 m <input type="checkbox"/> 1-way power point each Installed at the required location on the stand (only possible with stand assembly conducted by Wörnlein). If you are working with another stand assembly firm, please inform them or SAG GmbH about the power point required for the PC furniture/order it from them.		234.60 34.80
	39. Art. <input type="checkbox"/> PC furniture each width: 0.70 m, depth: 0.50 m height: 1.05 m top white, with rounded black edges and integrated socket aluminum frame with hidden HDMI- and network cables. <input type="checkbox"/> 1-way power point each Installed at the required location on the stand (only possible with stand assembly conducted by Wörnlein). If you are working with another stand assembly firm, please inform them or SAG GmbH about the power point required for the PC furniture/order it from them.		149.00 34.80

Other PC furniture available on request.
We are pleased to manufacture special furniture to individual order.







Leaflet stands

	40. Art. <input type="checkbox"/> Mero leaflet stand each width: 0.75 m, overall height: 1.25 m, 3 shelves 0.70 m/0.30 m, for 3 stacks of DIN A4 portrait format leaflets		62.20
---	---	--	-------





With our authorized signature below, we acknowledge acceptance of all items of the General and Special Terms of Business of NürnbergMesse and the General Terms of Business and the Special Conditions for Services of the ServicePartner.

Equipment	Description	Qty./m/m²	EUR
	41. Art. <input type="checkbox"/> Leaflet stand "Stap" each width: 0.27 m, overall height: 1.16 m, 4 shelves for DIN A4 portrait		57.70
	42. Art. <input type="checkbox"/> Leaflet stand "Slat" each width: 0.30 m, overall height: 1.65 m, 3 shelves for DIN A4 portrait format <input type="checkbox"/> per additional shelf, up to maximum 12 each		77.40 14.30
	43. Art. <input type="checkbox"/> Leaflet stand "Quadro" each frame: meroform chrome width: 0.25 m, overall height: 1.25 m with 3 shelves for DIN A4 vertical		57.10

Tables, standing tables







	44. Art. Table , height: 0.70 m, frame: chrome, color of top: <input type="checkbox"/> white <input type="checkbox"/> anthracite <input type="checkbox"/> 0.70 x 0.70 m each <input type="checkbox"/> 0.70 x 1.05 m each <input type="checkbox"/> 0.70 x 1.20 m each		27.00 28.60 33.00
	<input type="checkbox"/> beech <input type="checkbox"/> 0.70 x 0.70 m each <input type="checkbox"/> 0.70 x 1.05 m each <input type="checkbox"/> 0.70 x 1.20 m each		26.00 31.50 37.00
	45. Art. Table round , height: 0.70 m, frame: chrome, top: white <input type="checkbox"/> diameter: 0.70 m each <input type="checkbox"/> diameter: 0.90 m each <input type="checkbox"/> diameter: 1.50 m each		26.20 38.30 66.30
	46. Art. <input type="checkbox"/> Glass table "high tech" , height: 0.71 m, each frame: stainless steel, satinized glass top, round, 0.70 m diameter		63.30
	47. Art. <input type="checkbox"/> Table "Rondo" , each height: 0.70 m, diameter: 0.71 m frame: aluminum, top: <input type="checkbox"/> beech <input type="checkbox"/> white <input type="checkbox"/> anthracite		37.50
	48. Art. <input type="checkbox"/> Table "Global" , each height: 0.70 m, diameter: 0.70 m, frame: beech/aluminum, top: beech		36.40
	49. Art. <input type="checkbox"/> Standing table "Rondo" each height: 1.10 m, diameter: 0.70 m, frame: aluminum, color of top: <input type="checkbox"/> beech <input type="checkbox"/> white <input type="checkbox"/> anthracite		44.90

Order: Tables, standing tables (continued)

Equipment	Description	Qty./m/m²	EUR
	50. Art. Standing table "Quadro" , height: 1.15 m, frame: chrome/steel, top, color: <input type="checkbox"/> beech <input type="checkbox"/> white size of top: <input type="checkbox"/> diameter: 0.70 m each <input type="checkbox"/> diameter: 0.90 m each		44.40 44.90
	51. Art. <input type="checkbox"/> Standing table "high tech" each height: 1.10 m, diameter: 0.70 m, frame: stainless steel top: satinized glass, 8 mm		86.20
	52. Art. <input type="checkbox"/> Side table "Romeo" each frame: aluminum look top: satinized glass, 0.40 x 0.40 cm		46.40
	53. Art. <input type="checkbox"/> Side table "Wood" each coated, 0.55 x 0.55 m, 0.45 m high: <input type="checkbox"/> white <input type="checkbox"/> black		17.90

Chairs

	54. Art. <input type="checkbox"/> Upholstered chair "Thonet" each with arm rest, frame: chrome upholstery: black		41.00
	55. Art. <input type="checkbox"/> Chair "m.o.d." each frame: silver effect, seat: <input type="checkbox"/> without armrest <input type="checkbox"/> with armrest		38.60
	56. Art. <input type="checkbox"/> Chair "Relax" each frame: gray, seat: black leather		34.80
	57. Art. <input type="checkbox"/> Designer chair "SiM" each frame: chrome seat: white plastic		36.60
	58. Art. <input type="checkbox"/> Wicker chair , frame: chrome each seat: wicker work synthetic ecru		21.90
	59. Art. <input type="checkbox"/> Chair "Rondo" each frame: chrome, seat: beech <input type="checkbox"/> natural beech <input type="checkbox"/> red <input type="checkbox"/> orange <input type="checkbox"/> light blue <input type="checkbox"/> apple green <input type="checkbox"/> gray <input type="checkbox"/> white		21.50

Equipment	Description	Qty./m/m²	EUR
	60. Art. <input type="checkbox"/> Designer chair "Ken" each frame: chrome, seat: beech varnished in wenge color		21.20
	61. Art. <input type="checkbox"/> Upholstered chair "Classic" each <input type="checkbox"/> frame: chrome/anthracite, upholstery: <input type="checkbox"/> anthracite <input type="checkbox"/> blue <input type="checkbox"/> red <input type="checkbox"/> brown		18.00
	62. Art. <input type="checkbox"/> Upholstered chair "Opus" each frame: chrome, upholstery: black		19.70
	63. Art. <input type="checkbox"/> Chair "Griot" , frame: chrome, each seat: plastic <input type="checkbox"/> black <input type="checkbox"/> silver <input type="checkbox"/> blue <input type="checkbox"/> green <input type="checkbox"/> yellow <input type="checkbox"/> red		16.60
	64. Art. <input type="checkbox"/> Plastic chair , frame chrome each plastic: gray, upholstery: gray		14.00
	65. Art. <input type="checkbox"/> Folding chair each <input type="checkbox"/> beech <input type="checkbox"/> metal, white		11.80

Bar stools

	66. Art. <input type="checkbox"/> Bar stool "Coma" each seat height: 0.75 m, frame: silver/chrome, seat: anthracite		42.80
	67. Art. <input type="checkbox"/> Bar stool "Z" seat height: 0.90 m, upholstery: imitation leather, frame: chrome <input type="checkbox"/> black <input type="checkbox"/> white each <input type="checkbox"/> red <input type="checkbox"/> apple green <input type="checkbox"/> orange each		25.00 29.60
	68. Art. <input type="checkbox"/> Bar stool "Opus" each with backrest; seat height: 0.85 m, upholstery: black, frame: chrome		24.40
	69. Art. <input type="checkbox"/> Bar stool "Rondo" seat height: 0.90 m, frame: chrome <input type="checkbox"/> seat: beech each <input type="checkbox"/> seat: white each		36.10 41.70
	70. Art. <input type="checkbox"/> Bar stool "Lem" each seat height: 0.66-0.79 m frame: chrome matt, seat: white coated		73.00

With our authorized signature below, we acknowledge acceptance of all items of the General and Special Terms of Business of NürnbergMesse and the General Terms of Business and the Special Conditions for Services of the ServicePartner.

Place and date

Company stamp and authorized signature

Order: Lounge furniture (continued)

Equipment	Description	Qty./m/m ²	EUR
	70. Art. <input type="checkbox"/> Armchair "Romeo" seat: black leather each		60.70
	71. Art. <input type="checkbox"/> Couch "Romeo" synthetic leather, black, 2-seater each		152.00
	72. Art. <input type="checkbox"/> Bench width: 1.20 m, depth: 0.45 m height: 0.46 m upholstery synthetic leather <input type="checkbox"/> red <input type="checkbox"/> anthracite each		62.70
	73. Art. <input type="checkbox"/> Cube seat each imitation leather, 0.45 x 0.45 x 0.45 m <input type="checkbox"/> red <input type="checkbox"/> gray <input type="checkbox"/> anthracite		21.40

Coat stands, refrigerators, miscellaneous

	74. Art. <input type="checkbox"/> Coat stand with 6 hooks height: 1.75 m, color: black each		23.40
	75. Art. <input type="checkbox"/> Coat rack with 5 hooks color: white each		17.50
	76. Art. <input type="checkbox"/> Kitchen shelf unit of plastic each 0.80 x 0.40 x 1.87 m black, 4 shelves load 50 kg per shelf		40.50
	77. Art. <input type="checkbox"/> Refrigerator each width: 0.60 m, depth: 0.60 m, height: 0.80 m, capacity: approximately 140 liters		69.90
	78. Art. <input type="checkbox"/> Coffee percolator for 10 cups each		17.40
	79. Art. <input type="checkbox"/> Waste paper basket each		9.10
	80. Art. <input type="checkbox"/> Crockery		on request

Hourly rates, flame-retardant impregnation (Items 1–3b)

Item 1	Work at hourly rate	at	EUR 43.40
Item 2	Carpentry work:		
Item 2a	Machine hour	at	EUR 61.70
Item 2b	Installation hour	at	EUR 43.40
Item 2c	Workshop hour	at	EUR 41.80
Item 3a	Flame-retardant impregnation (natural fibers only) at hourly rate	at	EUR 43.40
Item 3b	Flame-retardant agent	liter	EUR 23.30
Item 4	Computer graphics	per hour	EUR 70.30

Special Conditions for Services provided by Messebau Wörnlein GmbH

- This order form also acts as the contract to supply goods, unless cancelled by us.
- Unless otherwise stated, the rental charge is calculated for the duration of the event.
- Please note: The following surcharges will be made for orders and orders with incomplete information received less than 14 days before the start of the event:
Services at fixed prices (e.g. furniture ...) 25 %
hourly work (e.g. modifications ...) 50 %.
- The price quoted includes delivery, assembly and dismantling. Reductions in the price per m² of rental and exhibition stands cannot be considered for any deduction in services requested by the exhibitor.
- Unless otherwise stated, all items listed are available for rental only.
- The stand holder is liable for any damage caused by inappropriate handling of walls and fascias, for example, screwing, nailing and use of strong adhesives.**
- Missing or damaged rental goods will be charged at the cost of replacement. The exhibitor's liability commences on delivery and ceases on collection by the ServicePartner (even if exhibitor has already left the stand), up to a maximum of 24 hours after the end of event. Rental articles are not insured. Exhibition insurance is therefore recommended!
Please note:
The stand and rental furniture listed above are to be insured by the ServicePartner. The insurance premium is 3 % of the rental charge.
 We do not require insurance and assume responsibility for all damage and losses in accordance with the above rental conditions.
- Exhibitors wishing to cancel orders must notify the ServicePartner in writing at least 10 days before the start of event, otherwise the full rental charge will be invoiced.
- Payment is due in full immediately on receipt of the invoice. International checks, credit cards and credit transfer from outside the EUR (€)-area will be charged with EUR 13.95.
- A processing fee of EUR 30 plus VAT at the statutory rate will be charged for issuing a new invoice due to incorrect information provided by the applicant. This fee will be included in the new invoice issued.
- All prices are subject to the addition of VAT at the statutory rate.**
- The place of fulfillment and jurisdiction for both parties, including debt collection proceedings, is Nürnberg.
The ServicePartner settles accounts with exhibitors during the event. The following credit cards are accepted: MasterCard, American Express, VISA.

With our authorized signature below, we acknowledge acceptance of all items of the General and Special Terms of Business of NürnbergMesse and the General Terms of Business and the Special Conditions for Services of the ServicePartner.

Place and date

Company stamp and authorized signature

Nuremberg, Germany
14-16.3.2017



embeddedworld2017

Exhibition & Conference
... it's a smarter world

Return to
NürnbergMesse GmbH
MesseService
Messezentrum
90471 Nürnberg
Tel +49 (0) 9 11. 86 06-80 00
Fax +49 (0) 9 11. 86 06-80 01
messe-service@nuernbergmesse.de

Contractor *
Hummel Möbelverleih GmbH
Messezentrum
90471 Nürnberg
Tel +49 (0) 9 11. 86 06-63 03
Fax +49 (0) 9 11. 86 06-63 04
nuernberg@hummel-mietmoebel.de
www.hummel-mietmoebel.de

Return deadline
14.12.2016

Hall/Stand

Company

Street

Postcode, Town, Country

Tel

Fax

E-mail

Person to contact

Tel

Fax

Invoice address (only if different)

Order (for Special Conditions for Services see back of Form S1.67)

VAT ID number of exhibitor:



Order: Seating

Equipment	Description	Qty.	EUR
	Art. 111 Armchair "Rondo" each fabric leather <input type="checkbox"/> white <input type="checkbox"/> black		68.00
	Art. 113 Armchair "Well" each chromium frame, fabric upholstery, black		64.00
	Art. 114 Armchair "Ro" each gray metal frame, fabric upholstery <input type="checkbox"/> gray <input type="checkbox"/> black		92.00

Equipment	Description	Qty.	EUR
	Art. 115 Armchair "Laja" each white aluminum frame, plastic seat shell with fabric seat cover <input type="checkbox"/> gray <input type="checkbox"/> red		89.00
	Art. 120 Chair "Bonni" each chromium frame, seat and back in plastic, white		15.50
	Art. 121 Armchair "Bonni" each chromium frame, fabric upholstery <input type="checkbox"/> red <input type="checkbox"/> blue <input type="checkbox"/> black		26.50

* If necessary, NürnbergMesse is entitled to have the service ordered provided by another ServicePartner. In this case, the customer will be notified of the other ServicePartner in good time.

With our authorized signature below, we acknowledge acceptance of all items of the General and Special Terms of Business of NürnbergMesse and the General Terms of Business and the Special Conditions for Services of the ServicePartner.

Place and date

Company stamp and authorized signature

Order: Seating (continued)

Equipment	Description	Qty.	EUR
	Art. 123 Stool "Mambo" height-adjustable, metal frame, translucent plastic seat <input type="checkbox"/> red <input type="checkbox"/> blue <input type="checkbox"/> transparent	each	39.50
	Art. 124 Stool "Plastic" polyethylene <input type="checkbox"/> red <input type="checkbox"/> blue <input type="checkbox"/> silver	each	19.50
	Art. 190 Stool "TX" matt-finish chromium frame, synthetic leather upholstery <input type="checkbox"/> white <input type="checkbox"/> black	each	38.50
	Art. 125 Chair "Bonni" chromium frame, fabric upholstery <input type="checkbox"/> red <input type="checkbox"/> blue <input type="checkbox"/> black	each	21.50
	Art. 126 Chair "Wood" chromium frame, beech seat shell <input type="checkbox"/> natural <input type="checkbox"/> white <input type="checkbox"/> black	each	22.00
	Art. 130 Chair "Noa" white metal frame, plastic seat shell, fabric upholstery, gray	each	40.00
	Art. 131 Chair "Vitra.03" gray metal frame, plastic seat, black	each	66.50
	Art. 132 Chair "Hoop" chromium frame, plastic seat shell <input type="checkbox"/> red <input type="checkbox"/> blue <input type="checkbox"/> white <input type="checkbox"/> charcoal gray	each	33.00
	Art. 133 Chair "Gliss" chromium frame, polypropylene seat shell <input type="checkbox"/> red <input type="checkbox"/> white <input type="checkbox"/> black	each	38.00
	Art. 134 Chair "Catifa" chromium frame, plastic seat shell, white	each	35.00
	Art. 135 Chair "Felix.3" white metal frame, plastic seat shell, white	each	34.50
	Art. 136 Chair "Kuadra" matt-finish chromium frame, plastic seat shell <input type="checkbox"/> red <input type="checkbox"/> opal	each	28.00
	Art. 136 Chair "Kuadra" chromium frame, plastic seat shell, white	each	28.00
	Art. 138 Chair "Body to Body" chromium frame, plastic seat shell, <input type="checkbox"/> white <input type="checkbox"/> translucent-red <input type="checkbox"/> translucent-blue	each	30.00
	Art. 139 Armchair "Jet" plastic <input type="checkbox"/> white <input type="checkbox"/> black	each	48.00

Equipment	Description	Qty.	EUR
	Art. 140 Chair "Panton" polyethylene <input type="checkbox"/> red <input type="checkbox"/> white <input type="checkbox"/> blue	each	42.00
	Art. 141 Armchair "Fjord" chromium frame, polypropylene seat shell, white, fabric upholstery <input type="checkbox"/> red <input type="checkbox"/> black	each	95.00
	Art. 143 Backless bench "Sidus" plastic <input type="checkbox"/> white <input type="checkbox"/> black	each	59.50
	Art. 144 Armchair "Nami" chromium frame, polyethylene seat <input type="checkbox"/> white <input type="checkbox"/> black	each	43.50
	Art. 147 Chair "Cloud" aluminum frame, plastic seat <input type="checkbox"/> red <input type="checkbox"/> charcoal gray <input type="checkbox"/> blue	each	33.50
	Art. 148 Armchair "PoppyStar" thermoplastic <input type="checkbox"/> red <input type="checkbox"/> blue <input type="checkbox"/> black <input type="checkbox"/> light gray <input type="checkbox"/> cream	each	28.50
	Art. 149 Chair "Breeze" aluminum frame, plastic seat and back <input type="checkbox"/> blue <input type="checkbox"/> white <input type="checkbox"/> red <input type="checkbox"/> black <input type="checkbox"/> gray	each	32.00
	Art. 150 Chair "Kicca" chromium frame, plastic seat shell <input type="checkbox"/> white <input type="checkbox"/> black <input type="checkbox"/> gray <input type="checkbox"/> orange <input type="checkbox"/> green <input type="checkbox"/> red	each	31.00
	Art. 151 Chair "Tweet" chromium frame, plastic seat shell <input type="checkbox"/> white/red <input type="checkbox"/> white/gray <input type="checkbox"/> white/orange <input type="checkbox"/> white/green <input type="checkbox"/> white/black	each	31.00
	Art. 152 Backless bench "Ikon" white polypropylene frame, polypropylene seat, white	each	78.00
	Art. 152 Backless bench "Ikon" black polypropylene frame, polypropylene seat, black	each	78.00
	Art. 153 Armchair "Tweet" black metal frame, plastic seat shell, white/black	each	39.00
	Art. 154 Chair "Volt" polyethylene <input type="checkbox"/> blue <input type="checkbox"/> white <input type="checkbox"/> charcoal gray <input type="checkbox"/> red	each	25.00
	Art. 155 Armchair "Volt" polyethylene <input type="checkbox"/> blue <input type="checkbox"/> white <input type="checkbox"/> charcoal gray <input type="checkbox"/> red	each	32.00
	Art. 156 Chair "Verge" wooden frame, SKY seat shell, white	each	47.00
	Art. 157 Chair "About A Chair" natural oak frame, polypropylene seat <input type="checkbox"/> white <input type="checkbox"/> gray <input type="checkbox"/> black	each	48.00

With our authorized signature below, we acknowledge acceptance of all items of the General and Special Terms of Business of NürnbergMesse and the General Terms of Business and the Special Conditions for Services of the ServicePartner.

Place and date

Company stamp and authorized signature

Order: Seating (continued)

Equipment	Description	Qty.	EUR
	Art. 158 Armchair "Pass" white metal frame, fabric upholstery <input type="checkbox"/> blue <input type="checkbox"/> red	each	95.00
	Art. 158 Armchair "Pass" black metal frame, fabric upholstery, charcoal gray	each	95.00
	Art. 159 Armchair "Log" fabric upholstery, gray	each	75.00
	Art. 160 Stool "Sat" with wooden desktop, plastic body <input type="checkbox"/> white <input type="checkbox"/> light gray	each	97.00
	Art. 161 Chair "Babila" chromium frame, plastic seat shell, white	each	67.00
	Art. 176 Folding chair "Pocket" gray metal frame, plastic seat and back <input type="checkbox"/> blue <input type="checkbox"/> white <input type="checkbox"/> charcoal gray	each	14.00
	Art. 183 Chair "Platero" aluminum frame, aluminum seat and back	each	23.00
	Art. 184 Armchair "Cuba" aluminum frame, wicker seat and back <input type="checkbox"/> black <input type="checkbox"/> blue	each	30.00

Bar stools

	Art. 409 Bar stool "Coma" aluminum frame, seat polyethylene <input type="checkbox"/> red <input type="checkbox"/> black <input type="checkbox"/> white <input type="checkbox"/> orange <input type="checkbox"/> green <input type="checkbox"/> blue	each	49.00
	Art. 410 Bar stool "Miura" polyethylene <input type="checkbox"/> red <input type="checkbox"/> black <input type="checkbox"/> white <input type="checkbox"/> orange <input type="checkbox"/> blue <input type="checkbox"/> light blue <input type="checkbox"/> light green <input type="checkbox"/> dark red	each	39.50
	Art. 411 Bar stool "Rio" with back rest, chromium frame, fabric upholstery <input type="checkbox"/> blue <input type="checkbox"/> black	each	31.00
	Art. 412 Bar stool "Move" swivel seat, chromium frame, leather upholstery <input type="checkbox"/> black <input type="checkbox"/> red	each	43.00
	Art. 414 Bar stool "Bilbao" aluminum frame, beechwood seat, natural	each	40.50
	Art. 415 Bar stool "Kuadra" matt-finish chromium frame, plastic seat shell, white	each	39.00
	Art. 415 Bar stool "Kuadra" white metal frame, plastic seat shell, white	each	39.00
	Art. 416 Bar stool "Z" chromium frame, synthetic leather upholstery <input type="checkbox"/> white <input type="checkbox"/> black <input type="checkbox"/> natural beech	each	25.00

Equipment	Description	Qty.	EUR
	Art. 417 Bar stool "Kicca" chromium frame, polypropylene seat shell <input type="checkbox"/> black <input type="checkbox"/> white <input type="checkbox"/> gray <input type="checkbox"/> orange <input type="checkbox"/> green <input type="checkbox"/> red	each	49.00
	Art. 418 Bar stool "Malaga" aluminum frame, aluminum seat and back	each	30.00
	Art. 419 Bar stool "Gliss" white metal frame, plastic seat shell, white	each	49.00
	Art. 419 Bar stool "Gliss" chromium frame, plastic seat shell, white	each	49.00
	Art. 420 Bar stool "Cube" matt-finish chromium frame, synthetic leather upholstery <input type="checkbox"/> white <input type="checkbox"/> black <input type="checkbox"/> dark brown	each	51.00
	Art. 421 Bar stool "Bitter" aluminum frame, aluminum seat	each	46.00
	Art. 422 Bar stool "Volt" polyethylene <input type="checkbox"/> white <input type="checkbox"/> blue <input type="checkbox"/> charcoal gray <input type="checkbox"/> red	each	43.00
	Art. 423 Bar stool "Noon" chromium frame, height-adjustable, technopolymer seat <input type="checkbox"/> red <input type="checkbox"/> charcoal gray <input type="checkbox"/> cream	each	69.00
	Art. 424 Bar stool "Hoop" chromium frame, plastic seat shell <input type="checkbox"/> white <input type="checkbox"/> blue <input type="checkbox"/> red <input type="checkbox"/> charcoal gray	each	49.00
	Art. 425 Bar stool "TX" matt-finish chromium frame, synthetic leather seat <input type="checkbox"/> white <input type="checkbox"/> black	each	51.00
	Art. 426 Bar stool "Stella" chromium frame, molded wood seat <input type="checkbox"/> blackwood <input type="checkbox"/> moccawood	each	68.00
	Art. 427 Bar stool "Mambo" height-adjustable, metal frame, translucent plastic seat <input type="checkbox"/> red <input type="checkbox"/> blue <input type="checkbox"/> lucent	each	72.00
	Art. 428 Bar stool "Breeze" aluminum frame, plastic seat and back <input type="checkbox"/> blue <input type="checkbox"/> white <input type="checkbox"/> red <input type="checkbox"/> black <input type="checkbox"/> gray	each	44.00
	Art. 429 Bar stool "Lem New" white metal frame, height-adjustable, seat <input type="checkbox"/> beech white <input type="checkbox"/> fabric blue <input type="checkbox"/> fabric red <input type="checkbox"/> fabric orange <input type="checkbox"/> fabric light green <input type="checkbox"/> fabric dark green <input type="checkbox"/> fabric purple	each	72.00
	Art. 429 Bar stool "Lem New" black metal frame, height-adjustable, beechwood seat, black	each	72.00

With our authorized signature below, we acknowledge acceptance of all items of the General and Special Terms of Business of NürnbergMesse and the General Terms of Business and the Special Conditions for Services of the ServicePartner.

Place and date

Company stamp and authorized signature

Order: Bar stools (continued)

Equipment	Description	Qty.	EUR
	Art. 429 Bar stool "Lem" each matt-finish chromium frame, height-adjustable, beechwood seat <input type="checkbox"/> white <input type="checkbox"/> black <input type="checkbox"/> natural <input type="checkbox"/> walnut <input type="checkbox"/> fabric black		72.00
	Art. 430 Bar stool "Leo" each aluminum frame, leather seat <input type="checkbox"/> white <input type="checkbox"/> black		58.00
	Art. 431 Bar stool "Tweet-Black" each black metal frame, polypropylene seat shell, white/black		49.00
	Art. 433 Bar stool "About A Stool" each natural oak frame, seat polypropylene <input type="checkbox"/> white <input type="checkbox"/> black <input type="checkbox"/> gray		49.00
	Art. 434 Bar stool "Tweet" each chromium frame, seat polypropylene, white/black		44.00

Tables

	Art. 200 Table „70/70“ each chromium frame, 70/70 cm/72 cm high, top white		28.00
	Art. 201 Table "Square" each black frame, 70/70 cm/75 cm high <input type="checkbox"/> top white <input type="checkbox"/> top black		39.00
	Art. 202 Table "Laja-60/60" each white metal frame, 60/60 cm/73 cm high, top white		46.00
	Art. 203 Table "Laja-80/80" each white metal frame, 80/80 cm/73 cm high, top white		49.00
	Art. 204 Table "Stylus-69/69" each white metal frame, 69/69 cm/74 cm high, top white		55.00
	Art. 204 Table "Stylus-69/69" each black metal frame, 69/69 cm/74 cm high, top black		55.00
	Art. 205 Table "Stylus-79/79" each white metal frame, 79/79 cm/74 cm high, top white		60.00
	Art. 205 Table "Stylus-79/79" each black metal frame, 79/79 cm/74 cm high, top black		60.00
	Art. 210 Table „120/70“ each chromium frame, 120/70 cm/72 cm high, top white		33.00
	Art. 210 Table „120/70“ each matt-finish chromium frame, 120/70 cm/72 cm high, natural beech top		63.00

Equipment	Description	Qty.	EUR
	Art. 211 Table "Semi" each chromium folding frame, 120/40 cm/74 cm high, top white		33.00
	Art. 213 Table "Arki" each white metal frame, 200/100 cm/74 cm high, top white		365.00
	Art. 214 Table „140/80“ each matt-finish chromium frame, 140/80 cm/72 cm high, top white		88.00
	Art. 215 Table "Mondo" each chromium folding frame, 120/80 cm/75 cm high <input type="checkbox"/> top white <input type="checkbox"/> top black		39.50
	Art. 216 Table "Toledo-130" each laminated wood, 130/60 cm/70 cm high, <input type="checkbox"/> white <input type="checkbox"/> black		120.00
	Art. 216 Table "Toledo-170" each laminated wood, 170/60 cm/70 cm high, <input type="checkbox"/> white <input type="checkbox"/> black		130.00
	Art. 216 Table "Toledo-200" each laminated wood, 200/60 cm/70 cm high, <input type="checkbox"/> white <input type="checkbox"/> black		150.00
	Art. 217 Conference table "Bonni" each chromium folding frame, 160/80 cm/72 cm high <input type="checkbox"/> top white <input type="checkbox"/> top black		117.00
	Art. 229 Table "Tonda-70/70" each matt-finish chromium frame, 70/70 cm/75 cm high <input type="checkbox"/> top white <input type="checkbox"/> top black		39.50
	Art. 229 Round table "Tonda" matt-finish chromium frame, 75 cm high, top white <input type="checkbox"/> Ø 60 <input type="checkbox"/> Ø 70 <input type="checkbox"/> Ø 80 top black <input type="checkbox"/> Ø 60 <input type="checkbox"/> Ø 70 <input type="checkbox"/> Ø 80 top charcoal gray <input type="checkbox"/> Ø 60 <input type="checkbox"/> Ø 70 <input type="checkbox"/> Ø 80 top natural beech <input type="checkbox"/> Ø 60 <input type="checkbox"/> Ø 80 top glass, clear <input type="checkbox"/> Ø 60 <input type="checkbox"/> Ø 70 top glass, frosted <input type="checkbox"/> Ø 60 <input type="checkbox"/> Ø 70	each	38.50
each		40.50	
each		40.50	
each		51.50	
each		73.50	
each		73.50	
	Art. 229 Table "Tonda-60/60" each matt-finish chromium frame 60/60 cm/75 cm high <input type="checkbox"/> top white <input type="checkbox"/> top black <input type="checkbox"/> top natural walnut		39.50
	Art. 230 Round table "Inox" matt-finish chromium frame, 74 cm high, top white <input type="checkbox"/> Ø 60 <input type="checkbox"/> Ø 70 <input type="checkbox"/> Ø 80 top black <input type="checkbox"/> Ø 60 <input type="checkbox"/> Ø 70 <input type="checkbox"/> Ø 80 top charcoal gray <input type="checkbox"/> Ø 60 <input type="checkbox"/> Ø 70 <input type="checkbox"/> Ø 80 top natural beech <input type="checkbox"/> Ø 60 <input type="checkbox"/> Ø 80 top glass, clear <input type="checkbox"/> Ø 60 <input type="checkbox"/> Ø 70 top glass, frosted <input type="checkbox"/> Ø 60 <input type="checkbox"/> Ø 70	each	39.50
each		41.50	
each		41.50	
each		51.50	
each		73.50	
each		73.50	

With our authorized signature below, we acknowledge acceptance of all items of the General and Special Terms of Business of NürnbergMesse and the General Terms of Business and the Special Conditions for Services of the ServicePartner.

Place and date



Company stamp and authorized signature

Order: Tables (continued)

Equipment	Description	Qty.	EUR
	Art. 230 Table "Inox-70/70" matt-finish chromium frame, 70/70 cm 74 cm high <input type="checkbox"/> top white <input type="checkbox"/> top black	each	40.50
	Art. 230 Table "Inox-60/60" matt-finish chromium frame, 60/60 cm 74 cm high <input type="checkbox"/> top white <input type="checkbox"/> top black <input type="checkbox"/> top natural walnut	each	40.50
	Art. 230 Table "Inox-Grande" 2 x matt-finish chromium frame, 200/70 cm/74 cm high <input type="checkbox"/> top white <input type="checkbox"/> top black	each	125.00
	Art. 231 Round table "Ikon" white polypropylene frame, 73 cm high, top white, <input type="checkbox"/> Ø 60 <input type="checkbox"/> Ø 80	each	56.50
	Art. 231 Round table "Ikon" black polypropylene frame, 73 cm high, top black <input type="checkbox"/> Ø 60 <input type="checkbox"/> Ø 80	each	56.50
	Art. 234 Round table "Urbis" matt-finish chromium frame, 75 cm high top white <input type="checkbox"/> Ø 60 <input type="checkbox"/> Ø 80 each top black <input type="checkbox"/> Ø 60 <input type="checkbox"/> Ø 80 each top natural beech <input type="checkbox"/> Ø 60 <input type="checkbox"/> Ø 80 each		38.50 40.50 51.50
	Art. 235 Round table "Sea" polished aluminum frame, Ø 80/73 cm high <input type="checkbox"/> top white <input type="checkbox"/> top black <input type="checkbox"/> top charcoal gray	each	55.50
	Art. 235 Table "Sea-70/70" polished aluminum frame, 70/70 cm/73 cm high <input type="checkbox"/> top white <input type="checkbox"/> top black	each	55.50
	Art. 236 Round table "Step" black frame, 72 cm high top white <input type="checkbox"/> Ø 90 <input type="checkbox"/> Ø 100 top black <input type="checkbox"/> Ø 90 <input type="checkbox"/> Ø 100	each	43.50
	Art. 238 Round table "Major" black frame, 75 cm high, top white <input type="checkbox"/> Ø 110 <input type="checkbox"/> Ø 120	each	58.50
	Art. 240 Oval table "Plastic" polyethylene, 47/65 cm/76 cm high <input type="checkbox"/> red <input type="checkbox"/> blue <input type="checkbox"/> silver	each	41.50
	Art. 241 Table "Quadro" matt-finish chromium frame, compact aluminum top, 80/80 cm/75 cm high <input type="checkbox"/> top black <input type="checkbox"/> top gray	each	56.50
	Art. 282 Round table "Greece" aluminum frame, Ø 60/73 cm high, top inox	each	30.50
	Art. 283 Round table "Avangard" aluminum frame, Ø 70/73 cm high, top inox	each	48.50

High tables

	Art. 284 High table "Stylus-59/59" black metal frame, top black	each	65.00
---	---	------	-------

Equipment	Description	Qty.	EUR
	Art. 284 High table "Stylus-59/59" each white metal frame, top white	each	65.00
	Art. 285 High table "Tall" round, black frame, 114 cm high top white <input type="checkbox"/> Ø 60 <input type="checkbox"/> Ø 70 top black <input type="checkbox"/> Ø 60 <input type="checkbox"/> Ø 70 top charcoal gray <input type="checkbox"/> Ø 60 <input type="checkbox"/> Ø 70 top mock beech <input type="checkbox"/> Ø 60	each	38.50
	Art. 286 High table "Ypsilon" round, aluminum frame, Ø 60/113 cm high, top inox	each	46.50
	Art. 287 High table "Tonda" round, matt-finish chromium frame, 114 cm high top white <input type="checkbox"/> Ø 60 <input type="checkbox"/> Ø 70 each top black <input type="checkbox"/> Ø 60 <input type="checkbox"/> Ø 70 each top charcoal gray <input type="checkbox"/> Ø 60 <input type="checkbox"/> Ø 70 each top natural walnut <input type="checkbox"/> Ø 60 each top natural beech <input type="checkbox"/> Ø 60 each top glass, clear <input type="checkbox"/> Ø 60 <input type="checkbox"/> Ø 70 each top glass, frosted <input type="checkbox"/> Ø 60 <input type="checkbox"/> Ø 70 each		57.50 57.50 57.50 57.50 67.50 81.50 81.50
	Art. 287 High table "Tonda-60/60" matt-finish chromium frame, 60/60 cm, 114 cm high <input type="checkbox"/> top white <input type="checkbox"/> top black each <input type="checkbox"/> top natural walnut each		57.50 60.50
	Art. 288 High table "Quickstep" round, Ø 70, 113 cm high (suitable for outdoor use) <input type="checkbox"/> white <input type="checkbox"/> graphite	each	27.50
	Art. 289 High table "Quadro" matt-finish chromium frame, 60/60 cm/113 cm high, top inox	each	67.50
	Art. 290 High table "Inox" round, matt-finish chromium frame, 114 cm high top white <input type="checkbox"/> Ø 60 <input type="checkbox"/> Ø 70 each top black <input type="checkbox"/> Ø 60 <input type="checkbox"/> Ø 70 each top charcoal gray <input type="checkbox"/> Ø 60 <input type="checkbox"/> Ø 70 each top natural walnut <input type="checkbox"/> Ø 60 each top natural beech <input type="checkbox"/> Ø 60 each top glass, clear <input type="checkbox"/> Ø 60 <input type="checkbox"/> Ø 70 each top glass, frosted <input type="checkbox"/> Ø 60 <input type="checkbox"/> Ø 70 each		57.50 57.50 57.50 57.50 62.50 81.50 81.50
	Art. 290 High table "Inox-60/60" matt-finish chromium frame, 60/60 cm/114 cm high <input type="checkbox"/> top white <input type="checkbox"/> top black each <input type="checkbox"/> top natural walnut each		57.50 60.50
	Art. 290 High table "Inox-Grande" 2 x matt-finish chromium frame, 120/60 cm/114 cm high <input type="checkbox"/> top white <input type="checkbox"/> top black	each	115.00
	Art. 291 High table "Viena" round, aluminum frame, Ø 60/113 cm high, top inox	each	60.50
	Art. 293 High table "Sea" round, polished aluminum frame, 108 cm high top white <input type="checkbox"/> Ø 60 <input type="checkbox"/> Ø 70 top black <input type="checkbox"/> Ø 60 <input type="checkbox"/> Ø 70 top charcoal gray <input type="checkbox"/> Ø 60 <input type="checkbox"/> Ø 70	each	63.50
	Art. 293 High table "Sea-60/60" polished aluminum frame, 60/60 cm/108 cm high <input type="checkbox"/> top white <input type="checkbox"/> top black	each	63.50

With our authorized signature below, we acknowledge acceptance of all items of the General and Special Terms of Business of NürnbergMesse and the General Terms of Business and the Special Conditions for Services of the ServicePartner.

Place and date

Company stamp and authorized signature

Order: High tables (continued)

Equipment	Description	Qty.	EUR
	Art. 295 High table "Toledo" wood laminate in white, 60/60 cm/110 cm high	each	110.00
	Art. 295 High table "Toledo" wood laminate in black, 60/60 cm/110 cm high	each	110.00
	Art. 295 High table "Toledo" wood laminate in black <input type="checkbox"/> 130/60 cm/110 cm high <input type="checkbox"/> 170/60 cm/110 cm high <input type="checkbox"/> 200/60 cm/110 cm high	each each each	120.00 130.00 150.00
	Art. 295 High table "Toledo" wood laminate in white <input type="checkbox"/> 130/60 cm/110 cm high <input type="checkbox"/> 170/60 cm/110 cm high <input type="checkbox"/> 200/60 cm/110 cm high	each each each	120.00 130.00 150.00
	Art. 296 High table "Ikon" round, white polypropylene frame, Ø 60/110 cm high, top white	each	73.50
	Art. 296 High table "Ikon" round, black polypropylene frame, Ø 60/110 cm high, top black	each	73.50

Lounge furniture

	Art. 085 Club chair "Rio" chromium frame, fabric upholstery <input type="checkbox"/> red <input type="checkbox"/> charcoal gray	each	154.00
	Art. 086 Club chair "Nimrod" polyethylene frame, fabric upholstery <input type="checkbox"/> yellow <input type="checkbox"/> green <input type="checkbox"/> purple <input type="checkbox"/> orange	each	139.00
	Art. 087 Stool "Dado" chromium frame, upholstery synthetic leather <input type="checkbox"/> black <input type="checkbox"/> white	each	72.00
	Art. 088 Single-seater "Dado" chromium frame, upholstery synthetic leather <input type="checkbox"/> black <input type="checkbox"/> white	each	104.00
	Art. 089 Corner seat "Dado" chromium frame, upholstery synthetic leather <input type="checkbox"/> black <input type="checkbox"/> white	each	127.00
	Art. 090 Stool "Wow" square, upholstery synthetic leather, 36/36 cm <input type="checkbox"/> black <input type="checkbox"/> white	each	36.00
	Art. 091 Bench "Wow" square, upholstery synthetic leather, 91/36 cm <input type="checkbox"/> black <input type="checkbox"/> white	each	58.00
	Art. 092 Stool "Wow" round, upholstery synthetic leather, Ø 40 cm <input type="checkbox"/> black <input type="checkbox"/> white	each	36.00
	Art. 093 Stool "Wow" round, upholstery synthetic leather, Ø 65 cm <input type="checkbox"/> black <input type="checkbox"/> white	each	56.00

Equipment	Description	Qty.	EUR
	Art. 094 Club chair "Petit Plateau" swivelling, aluminum frame, fabric upholstery, charcoal gray	each	365.00
	Art. 095 Stool "Host-Modular" chromium frame, upholstery synthetic leather <input type="checkbox"/> black <input type="checkbox"/> white	each	84.00
	Art. 096 Single-seater "Host-Modular" chromium frame, upholstery synthetic leather <input type="checkbox"/> black <input type="checkbox"/> white	each	99.00
	Art. 097 Two-seater "Host-Modular" chromium frame, upholstery synthetic leather <input type="checkbox"/> black <input type="checkbox"/> white	each	130.00
	Art. 098 Corner seat "Host-Modular" chromium frame, upholstery synthetic leather <input type="checkbox"/> black <input type="checkbox"/> white	each	110.00
	Art. 099 Cube "Big-Ben" synthetic leather, white	each	75.00
	Art. 100 Club chair "Curve" chromium frame, seat and back cherry, natural	each	42.00
	Art. 101 Stool "AP" oak <input type="checkbox"/> black <input type="checkbox"/> blanched	each	60.00
	Art. 102 Cube "Ben" synthetic leather <input type="checkbox"/> black <input type="checkbox"/> white	each	25.00
	Art. 103 Club chair "Tamago" chromium frame, fabric upholstery, charcoal gray	each	62.00
	Art. 104 Club chair "Slide" chromium frame, fabric upholstery <input type="checkbox"/> black <input type="checkbox"/> blue	each	44.00
	Art. 105 Club chair "Slide" with arm rests, chromium frame, fabric upholstery <input type="checkbox"/> black <input type="checkbox"/> blue	each	54.00
	Art. 106 Two-seater "Nero" fabric upholstery, black	each	199.00
	Art. 106 Two-seater "Nero" upholstery synthetic leather <input type="checkbox"/> black <input type="checkbox"/> white	each	199.00
	Art. 107 Single-seater "Delta" aluminum legs, fabric upholstery <input type="checkbox"/> gray <input type="checkbox"/> red <input type="checkbox"/> black	each	168.00
	Art. 108 Two-seater "Delta" aluminum legs, fabric upholstery <input type="checkbox"/> gray <input type="checkbox"/> red <input type="checkbox"/> black	each	304.00

With our authorized signature below, we acknowledge acceptance of all items of the General and Special Terms of Business of NürnbergMesse and the General Terms of Business and the Special Conditions for Services of the ServicePartner.

Place and date _____

Company stamp and authorized signature _____

Order: Lounge furniture (continued)



Equipment	Description	Qty.	EUR	Equipment	Description	Qty.	EUR
	Art. 109 Stool "Host" each chromium frame, upholstery synthetic leather <input type="checkbox"/> black <input type="checkbox"/> white		85.00		Art. 083 Side table "Toledo-45" each wood laminate in black, 45/45 cm/45cm high		60.00
	Art. 110 Club chair "Host" each chromium frame, upholstery synthetic leather <input type="checkbox"/> black <input type="checkbox"/> white		102.00		Art. 083 Side table "Toledo-45" each wood laminate in white, 45/45 cm/45cm high		60.00
	Art. 907 Two-seater "Highchair" each upholstered, charcoal gray		280.00		Art. 084 Side table "Sea" each round, polished aluminum frame, 43 cm high top white <input type="checkbox"/> Ø 60 <input type="checkbox"/> Ø 70 top black <input type="checkbox"/> Ø 60 <input type="checkbox"/> Ø 70 top charcoal gray <input type="checkbox"/> Ø 60 <input type="checkbox"/> Ø 70		50.00
	Art. 908 Single-seater "Klasse" each aluminum legs, upholstery synthetic leather, black		120.00		Art. 218 Side table "Alpha" each aluminum legs, 55/55 cm/27 cm high, top gray		57.00
	Art. 909 Two-seater "Klasse" each aluminum legs, upholstery synthetic leather, black		240.00		Art. 220 Side table "Toe" each matt-finish chromium frame, 67/67 cm/34 cm high, top white		76.00
	Art. 910 Single-seater "Vega" each matt-finish chromium frame, leather upholstery, black		180.00		Art. 221 Side table "Tria" each matt-finish chromium frame, 57/50cm/37 cm high <input type="checkbox"/> top black <input type="checkbox"/> top white <input type="checkbox"/> top walnut		75.00
	Art. 911 Two-seater "Vega" each matt-finish chromium frame, leather upholstery, black		350.00		Art. 222 Side table "Bahama" each rattan frame in brown, 51/51 cm/42 cm high, top glass		48.00
	Art. 912 Single-seater "Bahama" each rattan frame in brown, fabric upholstery, beige		97.00		Art. 223 Club-Table "Slide" each chromium frame, 64/64 cm/38 cm high, top white		36.00
	Art. 913 Two-seater "Bahama" each rattan frame in brown, fabric upholstery, beige		192.00		Art. 224 Side table "Toe" each matt-finish chromium frame, 128/67 cm/34 cm high, top white		97.00
	Art. 918 Single-seater "Qubo" each metal legs, upholstery synthetic leather <input type="checkbox"/> white <input type="checkbox"/> black		98.00		Art. 225 Side table "Eileen Gray" each height-adjustable, chromium frame, Ø 51 cm/60 cm-100 cm high, top glass		60.00
	Art. 919 Two-seater "Qubo" each metal legs, upholstery synthetic leather <input type="checkbox"/> white <input type="checkbox"/> black		178.00		Art. 226 Club-Table "Barcelona" each chromium frame, 90/90 cm/46 cm high, top glass		125.00
	Art. 080 Side table "Pocket" each white metal frame, top white		63.00		Art. 227 Club-Table "Granada" each chromium frame, Ø 70 cm/53 cm high, top glass		125.00
	Art. 081 Side table "Stylus-59/59" each white metal frame, top white		50.00		Art. 228 Club-Table "Ronda" each matt-finish chromium frame, Ø 50 cm/51 cm high, top glass		60.00
	Art. 081 Side table "Stylus-59/59" each black metal frame, top black		50.00	Office furniture			
	Art. 082 Side table "Ikon" each round, white polypropylene frame, Ø 60 cm, top white		57.00		Art. 302 Desk "Mondo" each Cabinet on rollers, metal, 120/80 cm/75 cm high <input type="checkbox"/> white <input type="checkbox"/> black		85.00
	Art. 082 Side table "Ikon" each round, black polypropylene frame, Ø 60 cm, top black		57.00		Art. 320 Swivel chair "Office" each height-adjustable, fabric upholstery, black		40.00

With our authorized signature below, we acknowledge acceptance of all items of the General and Special Terms of Business of NürnbergMesse and the General Terms of Business and the Special Conditions for Services of the ServicePartner.

Place and date

Company stamp and authorized signature



Order: Office furniture (continued)

Equipment	Description	Qty.	EUR
	Art. 324 Office swivel chair "Delby" each height-adjustable, black frame, fabric upholstery, black		60.00
	Art. 326 Office swivel chair "Luxy" each height-adjustable, metal frame, leather seat <input type="checkbox"/> black <input type="checkbox"/> white		90.00
	Art. 343 Cabinet on rollers "Steel" each metal, 42/59 cm/56 cm high <input type="checkbox"/> black <input type="checkbox"/> silver <input type="checkbox"/> white		60.00

Sideboards/cabinets/shelves

	Art. 330 File shelving 3 shelves, white plastic, 75/30 cm/86 cm high	each	20.00
	Art. 370 Locker cabinet "Big" 4 lockers, gray metal, 68/50 cm/180 cm high	each	97.00
	Art. 371 Locker cabinet "Silver" 4 lockers, gray metal, 36/50 cm/180 cm high	each	90.00
	Art. 372 Locker cabinet "Reno" 4 lockers, white laminated wood, 35/50 cm/200 cm high	each	90.00
	Art. 530 Multi-purpose shelving 5 shelves, white plastic, 75/30 cm/170 cm high	each	34.00
	Art. 584 Sideboard "Dax" lockable, silver body, top in multiplex birch, 100/50 cm/75 cm high	each	134.00
	Art. 585 Sideboard "Syma-Easy-408" white frame, white paneling, 100/50 cm/75 cm high	each	85.00
	Art. 585 Sideboard "Syma New" aluminum frame, white paneling 100/50 cm/75 cm high	each	85.00
	Art. 585 Sideboard "Syma New" aluminum frame, black paneling, 100/50 cm/75 cm high	each	91.00

Info counters/bar counters

	Art. 401 Bar counter "Syma Easy-408" white frame, 100/50 cm/125 cm high, white paneling	each	112.00
	Art. 406 Bar counter corner element "Syma Easy-408" white frame, 50/50 cm/125 cm high, white paneling	each	100.00
	Art. 401 Bar counter "Syma-New" aluminum frame, 100/50 cm/125 cm high <input type="checkbox"/> white paneling each 117.00 <input type="checkbox"/> black paneling each 122.00		

Equipment	Description	Qty.	EUR
	Art. 406 Bar counter corner element "Syma-New" aluminum frame, 50/50 cm/125 cm high <input type="checkbox"/> white paneling each 102.00 <input type="checkbox"/> black paneling each 107.00		
	Art. 407 Bar counter "Tetris" white plastic body, 145/80 cm/111 cm high (suitable for outdoor use)	each	187.00
	Art. 408 Bar counter corner element "Tetris" white plastic body, 89/97 cm/111 cm high (suitable for outdoor use)	each	167.00
	Art. 586 Display platform "Kant" white body, 100/50 cm/50 cm high	each	60.00
	Art. 588 Counter "Syma Easy-408" white frame, 100/50 cm/95 cm high, white paneling	each	96.00
	Art. 589 Counter corner element "Syma Easy-408" white frame, 50/50 cm/95 cm high, white paneling	each	73.00
	Art. 588 Counter "Syma-New" aluminum frame, 100/50 cm/95 cm high <input type="checkbox"/> white paneling each 99.00 <input type="checkbox"/> black paneling each 104.00		
	Art. 589 Counter corner element "Syma-New" aluminum frame, 50/50 cm/95 cm high <input type="checkbox"/> white paneling each 75.00 <input type="checkbox"/> black paneling each 80.00		
	Art. 590 Display column "Kant" white body, 50/50 cm/100 cm high	each	60.00
	Art. 592 Counter "Real" lockable, silver body, top in multiplex birch, 100/84 cm/120 cm high	each	299.00
	Art. 593 Rundcounter "Dax" lockable, silver body, top in multiplex birch, 170/50 cm/100 cm high	each	320.00
	Art. 594 Counter "Dax" lockable, silver body, top in multiplex birch, 150/50 cm/100 cm high	each	215.00
	Art. 605 Bar counter corner element "Igloo" white plastic, 90/70 cm/108 cm high, with lighting	each	185.00
	Art. 606 Bar counter "Igloo" white plastic, 140/70 cm/108 cm high, with lighting	each	205.00
	Art. 607 Bar counter "Loja-100" lockable, corpus charcoal gray, top: glass/stainless steel, on rollers 100/60 cm/120 cm	each	290.00
	Art. 608 Bar counter "Loja-125" lockable, corpus charcoal gray, top: glass/stainless steel, on rollers 125/60 cm/120 cm	each	290.00

With our authorized signature below, we acknowledge acceptance of all items of the General and Special Terms of Business of NürnbergMesse and the General Terms of Business and the Special Conditions for Services of the ServicePartner.

Place and date _____

Company stamp and authorized signature _____

Order: Info counters/bar counters (continued)

Equipment	Description	Qty.	EUR
	Art. 610 Counter "Nea" each white body, white top, 150/44 cm/110 cm high		375.00

Showcases

	Art. 570 Showcase "Octa" each lockable, without lighting, aluminum frame, 100/50 cm/95 cm high		88.00
	Art. 580 Showcase "Octa" each with substructure, lockable, without lighting, aluminum frame, 100/50 cm/95 cm high, white paneling		110.00
	Art. 581 Showcase "Syma Easy-408" each with substructure, lockable, without lighting, white frame, 100/50 cm/95 cm high, white paneling		129.00
	Art. 581 Showcase "Syma-New" with substructure, lockable, without lighting, aluminum frame, 100/50 cm/95 cm high <input type="checkbox"/> white paneling each 129.00 <input type="checkbox"/> black paneling each 134.00		
	Art. 595 Cabinet showcase "Trend" each with lighting, aluminum frame, 100/50 cm/180 cm high		175.00
	Art. 596 Cabinet showcase each "Syma Easy-408" with substructure, with lighting, white frame, 100/50 cm/180 cm high, white paneling		225.00
	Art. 596 Cabinet showcase "Kappa" each with substructure, with lighting, aluminum frame, 100/50 cm/180 cm high, white paneling		225.00
	Art. 597 Column showcase each "Syma-Easy-408" with substructure, with lighting white frame, 50/50 cm/180 cm high, white paneling		205.00
	Art. 597 Column showcase each "Syma New" with substructure, with lighting, aluminum frame, 50/50 cm/180 cm high, white paneling		205.00
	Art. 598 Column showcase each "Nice" with lighting, aluminum frame, 39/39 cm/180 cm high		205.00
	Art. 599 Column showcase each "Kappa" with substructure, lockable, with lighting, aluminum frame, 50/50 cm/190 cm high, white paneling		205.00
	Art. 602 Cabinet showcase each "Forum" fully glazed, with lighting, aluminum frame, 100/50 cm/180 cm high		265.00

Brochure racks

	Art. 532 Brochure rack "Pino 6" each gray metal frame, 6 DIN A4-size shelves, 44/40 cm/157 cm high		52.00
--	--	--	-------

Equipment	Description	Qty.	EUR
	Art. 534 Brochure rack "Shell" each matt-finish chromium frame, 3 aluminum shelves, 65/56 cm/130 cm high		45.00
	Art. 535 Brochure rack "PZ 6" each clear acrylic, 6 DIN A4-size shelves, 42/30 cm/154 cm high		89.00
	Art. 537 Brochure rack "Twin" each matt-finish chromium frame, 3 double-sided aluminum shelves, 51/50 cm/150 cm high		50.00
	Art. 538 Brochure rack "Punto 4" each gray metal frame, 4 DIN A4-size shelves, 30/60 cm/166 cm high		65.00
	Art. 539 Brochure rack "Punto 8" each gray metal frame, 8 DIN A4-size shelves, 35/54 cm/150 cm high		70.00

Clothes stands/coat racks

	Art. 500 Coat rack "Tube" each		23.00
	Art. 501 Coat rack "Bambu" metal frame, silver		33.00
	Art. 502 Coat rack "Flag", metal-polypropylene frame <input type="checkbox"/> white <input type="checkbox"/> black <input type="checkbox"/> red		40.00
	Art. 700 Clothes stand "Milano" each height-adjustable, chromium frame, 180 cm/140-180 cm high		28.00
	Art. 750 Upright mirror on rollers		46.00

Other furniture and accessories

	Art. 510 Waste paper basket each		7.00
	Art. 521 Umbrella stand "Rex" black		34.00
	Art. 543 Retractable belt barriers each "Flex" mobile, tape 2.00 m long, matt-finish chromium base (minimum order: 2 pylons) <input type="checkbox"/> belt tape blue <input type="checkbox"/> belt tape black		45.00
	Art. 545 Waste stand including 3 waste bags		30.00
	Art. 546 Waste bin "Pushboy" each powder-coated sheet steel, silver		40.00

With our authorized signature below, we acknowledge acceptance of all items of the General and Special Terms of Business of NürnbergMesse and the General Terms of Business and the Special Conditions for Services of the ServicePartner.

Place and date

Company stamp and authorized signature

Order: Other furniture and accessories (continued)

Equipment	Description	Qty.	EUR
	Art. 548 Lectern "Talk" chromium frame, 56/35 cm/110 cm high	each	120.00
	Art. 549 Bag holder "Chromato" matt-finish chromium frame	each	40.00
	Art. 800 Room divider free-standing, lightweight construction, aluminum frame, 19 mm hardboard panel in white, 62 cm wide (minimum order: 2 elements) <input type="checkbox"/> 210 cm high <input type="checkbox"/> 105 cm high	each each	42.00 21.00
	Art. 803 Room divider "Sticks" white fiber glass rod, natural rubber base panel	each	85.00
	Art. 804 Room divider "Leaf" polyethylene <input type="checkbox"/> white <input type="checkbox"/> green <input type="checkbox"/> light green	each	35.00
	Art. 901 Floor lamp "L001 St" white metal frame, lamp foot white, gray/white	each	175.00
	Art. 902 Table lamp "L001 TA" white metal frame, lamp foot white, gray/white	each	125.00

When ordering during the official assembly, rental prices are subject to a 25 % surcharge.

Special Conditions for Services provided by Hummel Möbelerleih GmbH

Payment conditions:

The invoice must be paid before the start of the exhibition or delivery. Foreign payments are requested by bank transfer in advance without charges. A collection charge of EUR 15 should be added to foreign checks.
A processing fee of EUR 50 plus VAT at the statutory rate will be charged for issuing a new invoice due to incorrect information provided by the applicant. This fee will be included in the new invoice issued.

Rental conditions

- The rental object is only made available for the agreed purpose and for the agreed period. An extension of the rental period shall require the written consent of the rental company. The rental company is entitled to invoice an additional rental charge if the rental object is not returned by the agreed time.
- The rental prices are calculated according to the duration of rental on the basis of the currently valid price list. The statutory VAT is to be added. For objects rented for a trade fair or exhibition the rental prices shall also include the costs for delivery and collection of the rental object within the exhibition grounds. In other cases the valid transport cost rates for delivery and collection of the rental object will be invoiced in addition to the rental price.
Invoiced rental prices are payable net. Direct orders directly before and during a trade fair are to be paid on award of the order. A collection charge of **EUR 15** will be made for foreign checks. Charges for payments remitted abroad shall be borne by the renter. If the renter is in default of payment, interest on arrears amounting to 5 % over and above the current discount rate of the Deutsche Bundesbank shall be charged.
- For loss or damage of the rental object compensation amounting to the cost of replacement may be claimed from the renter or the cost of repair if this does not exceed the replacement value. Liability shall commence with the takeover of the rental object by the renter and end with its collection by the rental company. In the case of objects rented for a trade fair, liability shall commence with delivery to the exhibition stand and end when it is collected from there. This shall also apply if the exhibition stand is not occupied. Liability shall end 24 hours after the end of the trade fair at the latest unless the rental object was not made available for collection or another collection date has been agreed. The rental company shall not be liable for damage to property or injury to persons in connection with the use of the rental object unless it is due to wilful action or gross negligence on the part of the rental company.
- The rental object is not insured. Insurance of the rental object for the period of a trade fair, including the stand construction and dismantling period, is recommended.
Important:
All rental furniture will be insured. The premium is equal to 3 % of the rental price and will be charged separately to the hiring party.
 We do not require insurance and acknowledge our liability as set forth in the rental terms contained herein.
- All orders with no specified date will be delivered in good time so that the rental object is available at the start of the fair. After the end of the fair the rental object will be collected as quickly as possible. The renter must make the rental object available for collection. If delivery or collection of the rental object is prevented by fault of the renter, the rental company shall be entitled to charge for any additional expenditure incurred. Renters collecting rental objects themselves are hereby notified that the objects may only be transported in suitable closed vehicles.
In the event of default of payment the rental company reserves the right to refuse delivery of the rental object or to fetch back delivered objects at an earlier date.
- Rental objects ordered in advance and reserved but not taken delivery of will be charged to the customer in full. If it is possible to rent them elsewhere the customer shall bear the costs incurred for delivery and collection and for any loss of rental fees.
In cases of unforeseeable damage the rental company reserves the right to supply equivalent or better replacement objects in place of the ordered rental objects. No claims can be asserted as a result of such replacements.
- Any complaints the renter may have must be made within 24 hours of the items concerned having been delivered. Any complaints made after this time will not be accepted.
- Place of performance and jurisdiction for the renter and rental company shall be the registered office of the rental company. The laws of the Federal Republic of Germany shall apply even for transactions with foreign customers.

With our authorized signature below, we acknowledge acceptance of all items of the General and Special Terms of Business of NürnbergMesse and the General Terms of Business and the Special Conditions for Services of the ServicePartner.

Place and date _____

Company stamp and authorized signature _____

Special styles in black/white:

(15 % surcharge on standard prices for Swiss 721 Md)

- Swiss 721 Md**
Standard type face for Helvetica
- Arial**
- American Type**
- Antique-Olive**
- Brush Script*
- Cooper**
- Eurostile**
- Times**
- VAG Round**
- Bodoni**
- Fuyijama (Futura)**
- Fuyijamaextra**
- Swiss 721 Hv**
- Swiss 721 Lt
- Gill Sans**
- News 701**
- Formal Script**
- Revue**

**Letter height
in mm**

150 mm

**Price per letter
excluding mounting**

EUR 1.85

**Price per letter
including mounting**

EUR 2.40

Other sizes on request.

Requirements for print data

Print data:

CMYK tiff files
CMYK eps files
Print-optimized pdf data
(fonts must be converted to paths, embedding is not sufficient)
transparency only in rasterized form

Resolution:

all lines, areas and fonts should be created as vector graphic; the data volume is smaller and the graphic can be enlarged as required.
The resolution must be based on the viewing distance for optimum reproduction of pixel images.

Colors:

Only colors in the CMYK color space (Euroscale) without additional special colors (HKS, Pantone etc.)
Black: C 80 %, M 60 %, Y 60 %, K 100 %
RGB data cannot be printed; it must be converted.

Nuremberg, Germany
14-16.3.2017



embeddedworld2017
 Exhibition&Conference
 ... it's a smarter world

Return to
 NürnbergMesse GmbH
 MesseService
 Messezentrum
 90471 Nürnberg
 Tel +49 (0) 9 11. 86 06-80 00
Fax +49 (0) 9 11. 86 06-80 01
 messeservice@nuernbergmesse.de

Contractor *
 Messebau Wörnlein GmbH
 Messezentrum
 90471 Nürnberg
 Tel +49 (0) 9 11. 81 74 49-0
 Fax +49 (0) 9 11. 81 74 49-25
 info@woernlein.de
 www.woernlein.de

Company _____

Street _____

Postcode, Town, Country _____

Tel _____

Fax _____

E-mail _____

Return deadline
14.12.2016

Hall/Stand

Person to contact _____

Tel _____

Fax _____

Invoice address (only if different) _____

Order: for Special Conditions for Services have a look at the Online ExhibitorShop under Stand Construction – Extra stand equipment / floor coverings / furniture – Stand equipment (contractor: Messebau Wörnlein GmbH). (PDF Form S1.66)

You can have your company name displayed on your stand fascia (height: 30 cm). Please select one of the standard styles shown below.
 Color: white black
 Other colors on request at 40 % surcharge.

- Arial**
- Avant Garde Bold Md BT**
- Clarendon Bold**
- Eurostile Extended**
- Futura Medium Md BT**
- Futura Bold Md BT**
- Garamond Bold**
- Gil Sans MT**
- Helvetica Light = Swiss Md BT**
- Helvetica Medium = Swiss 721 SWA**
- Souvenir Demi Bold**
- Times New Roman**
- VAG**
- Other styles on request. You can send lettering data for Mac or PC by e-mail: info@woernlein.de or FTP server.

VAT ID number of exhibitor:

--	--	--	--	--	--	--	--	--	--	--	--	--	--	--	--

Letter height in mm	Price per letter excluding mounting	Price per letter including mounting
<input type="checkbox"/> 150 mm	<input type="checkbox"/> EUR 1.95	<input type="checkbox"/> EUR 2.75

Other sizes on request.

Text for lettering on fascia:

* If necessary, NürnbergMesse is entitled to have the service ordered provided by another ServicePartner. In this case, the customer will be notified of the other ServicePartner in good time.
 With our authorized signature below, we acknowledge acceptance of all items of the General and Special Terms of Business of NürnbergMesse and the General Terms of Business and the Special Conditions for Services of the ServicePartner.

Digital printing – please note:

Please note:	System:	HP Latex
	Print width:	up to 1,500 mm sheet width
	Print data formats:	printable PDF files (to PDF/X-3), also TIF, JPG, and EPS (vector format, fonts converted into paths).

Data transmission:	E-mail info@woernlein.de Data FTP server (access on request)
Data transfer:	4 weeks prior to start of exhibition. In the case of data that cannot be printed directly, processing fees of EUR 83.80/hour apply.
Surcharge for small orders:	10 % of the m ² price for < 0.5 m ² of prints and laminates.

Ordering:

- 1** **Digital printing on paper** EUR 38.30/m²
(without assembly) 140/190 g/m²
- 2** **Digital printing on self-adhesive film**
- without assembly EUR 52.00/m²
- with assembly EUR 73.50/m²
- 3** **Digital printing on backlit film for light box**
- without assembly EUR 49.90/m²
- with assembly EUR 72.50/m²

Digital printing on textile (one-sided):

- 4** with keder profile top and bottom up to 5 m² EUR 88.50/m²
- with keder profile top and bottom starting at 5 m² EUR 80.50/m²
- with keder strips and fabric retaining profiles (modular system) up to 5 m² EUR 88.50/m²
- 5** with keder strips and fabric retaining profiles (modular system) starting at 5 m² EUR 80.50/m²
- (modular crossbeams: item 17 on the stand equipment and rental furniture form)

6 Textile clamping cubes (cube) including four-sided digital printing

Rental price including assembly and disassembly:

- Cube 1.00 x 1.00. h = 1.00 m EUR 855.00/each
- Cube 1.50 x 1.50. h = 1.00 m EUR 1,050.00/each
- Cube 2.00 x 2.00. h = 1.00 m EUR 1,251.00/each
- Cube 2.00 x 2.00. h = 2.00 m EUR 1,742.00/each
- Cube 2.50 x 2.50. h = 1.00 m EUR 1,452.00/each
- Cube 2.50 x 2.50. h = 1.50 m EUR 1,708.00/each
- Cube 3.00 x 3.00. h = 1.50 m EUR 2,000.00/each
- Cube 3.00 x 3.00. h = 2.00 m EUR 2,360.00/each
- Cube 3.00 x 3.00. h = 3.00 m EUR 2,988.00/each

Textile graphics become your property

- 7** 5th side for cube, digital printing on textile EUR 50.00/m²

Digital print on flooring:

- 8** **Vinyl flooring, 2 mm, B1, individual print** from 10 m² price including laying, removal and disposal
- from 10 m² EUR 57.90/m²
- from 30 m² EUR 54.90/m²
- from 50 m² EUR 48.90/m²

3D design:



Letters, logos, signets, oversized models, sculptures, laser cut from extruded rigid foam, for interior and exterior use. Prices available upon request.

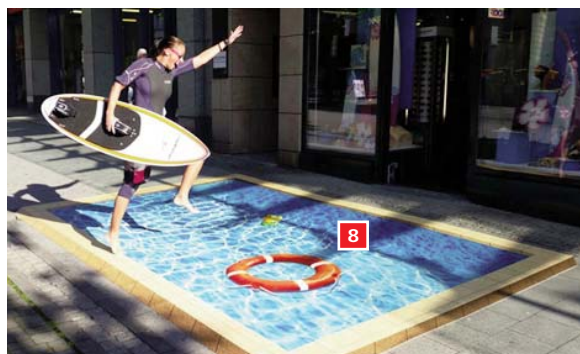

* If necessary, NürnbergMesse is entitled to have the service ordered provided by another ServicePartner. In this case, the customer will be notified of the other ServicePartner in good time.

With our authorized signature below, we acknowledge acceptance of all items of the General and Special Terms of Business of NürnbergMesse and the General Terms of Business and the Special Conditions for Services of the ServicePartner.

Place and date

Company stamp and authorized signature

Nuremberg, Germany
14–16.3.2017



embeddedworld2017

Exhibition & Conference
... it's a smarter world

Return to
NürnbergMesse GmbH
MesseService
Messezentrum
90471 Nürnberg
Tel +49 (0) 9 11. 86 06-80 00
Fax +49 (0) 9 11. 86 06-80 01
messeservice@nuernbergmesse.de

Company

Street

Postcode, Town, Country

Tel

Fax

E-mail

Return deadline
14.12.2016

Hall/Stand

Person to contact

Tel

Fax

Invoice address (only if different)

Order

VAT ID number of exhibitor:

<input type="text"/>	<input type="text"/>	<input type="text"/>	<input type="text"/>	<input type="text"/>	<input type="text"/>	<input type="text"/>	<input type="text"/>	<input type="text"/>	<input type="text"/>	<input type="text"/>	<input type="text"/>	<input type="text"/>	<input type="text"/>	<input type="text"/>	<input type="text"/>	<input type="text"/>	<input type="text"/>	<input type="text"/>	<input type="text"/>
----------------------	----------------------	----------------------	----------------------	----------------------	----------------------	----------------------	----------------------	----------------------	----------------------	----------------------	----------------------	----------------------	----------------------	----------------------	----------------------	----------------------	----------------------	----------------------	----------------------

These articles are intended only for use on the exhibition stand and not for promotional purposes in the gangways or on the exhibition site. Approved advertising options can be found in the marketing services section.



Illustration	Article	Qty.	EUR
	Articles for purchase		
1.	Digital prints Digital print, 720dpi on 140g poster paper <input type="checkbox"/> (Art. 30202002) DIN A1 poster each 38.00 <input type="checkbox"/> 2 or more of same subject each 25.00 <input type="checkbox"/> 5 or more of same subject each 17.00 <input type="checkbox"/> 10 or more of same subject each 16.00 <input type="checkbox"/> (Art. 30202003) DIN A0 poster each 55.00 <input type="checkbox"/> 2 or more of same subject each 38.00 <input type="checkbox"/> 5 or more of same subject each 31.00 <input type="checkbox"/> 10 or more of same subject each 25.00 Digital printing prices per m² (Minimum charge in each case is 1m ²) <input type="checkbox"/> (Art. 30202004) 140 g poster paper m ² 42.50 <input type="checkbox"/> (Art. 30202005) 200 g photo paper m ² 45.00 <input type="checkbox"/> (Art. 30202006) Lamination extra m ² 12.50		
	2. Roll-up banner incl. printing Norisbanner-Up 850 x 2000 mm with printing. NF Titania – The Norisbanner-Up roll banner is equipped with screw-out solid aluminum stand feet and an aluminum rail and is fixed by a clamping strip (at the top) and adhesive (at the bottom). It is supplied as standard with a canvas carrying bag with a full-width zip. The graphic is rolled up in the system to protect it during transport. A spring mechanism rolls up the graphic automatically. A unique system for your presentation. 3 months guarantee. Incl. banner as 4C digital print, 720 dpi <input type="checkbox"/> (Art. 30202010) Visible area: 850x2000mm each 221.00 Data format: 850x2100mm (100mm wider at bottom). File is provided ready for printing as PDF 1.4, jpg or tif. <input type="checkbox"/> (Art. 30202011) Visible area: 1000x2000mm each 250.00 Data format: 1000x2100mm (100mm wider at bottom). File is provided ready for printing as PDF 1.4, jpg or tif.		

Illustration	Article	Qty.	EUR
	3. Graphic articles Folding aluminum frame with 25mm profile, mitered corners and anti-reflex glass <input type="checkbox"/> (Art. 30202012) Folding frame DIN A2 each 35.00 <input type="checkbox"/> (Art. 30202013) Folding frame DIN A1 each 47.00 Folding aluminum frame with 32mm profile, mitered corners and anti-reflex glass <input type="checkbox"/> (Art. 30202014) Folding frame DIN A0 each 85.00		
	4. <input type="checkbox"/> (Art. 30202009) Customer stopper DIN A1 each 143.00 Customer stopper click A standard, double-sided DIN A1 presentation area (594 x 841mm)		

Please fill in for payment by credit card:

Issuer : MasterCard VISA American Express

Card no.: : _____ / _____ / _____ / _____

Card verification no.: (The last 3 digits next to the signature on the back of the card or for AMEX 4 digits on the front)

Expiry date : _____

Holder of card: _____

We authorize NürnbergMesse GmbH to charge the invoice amount to the above-mentioned credit card.

Signature: _____

Orders received later than 14 days before the start of the event will be billed an express surcharge of 25 %, subject to a minimum surcharge of EUR 10 per order. With our authorized signature below, we acknowledge acceptance of all items of the General and Special Terms of Business of NürnbergMesse and the General Terms of Business and the Special Conditions for Services of the ServicePartner.

Place and date

Company stamp and authorized signature

Print data

File formats

Your ready-to-print data have to be sent latest 4 weeks prior to the exhibition. Please send us your print data in PDF, TIF or JPG format.

Important: Data created in a photo editing program such as Photoshop must only be sent as TIF or JPG file. The data must be reduced to the background layer. Alpha channels and clipping paths are not allowed. This also applies to Photoshop files placed in a layout program!

TIF

- Reduce to background layer
- Alpha channels are not allowed
- Clipping paths are not allowed
- Save without compression, with interleaved pixel arrangement

JPG

- Use only standard JPG format (e.g. not JPG 2000)
- Save in maximum quality and with baseline (standard)

PDF

PDF data must comply with the PDF/X-3:2002 standard, which includes the following requirements:

- PDF must be version 1.3
- Transparencies are not allowed
- Comments and form fields are not allowed
- Encryptions (e.g. password protection) are not allowed
- OPI comments are not allowed
- Transfer curves are not allowed
- An output intent must be indicated

The following apply in addition to the requirements of the PDF/X-3:2002 standard:

- All fonts must be converted to paths
- Layers are not allowed

More information about PDF/X-3:2002 is available at www.pdf3.org.

Data format/bleed

Please create your print data as described in the data sheet for the respective product. Please note: As all data are centered, the subject must also always be placed in the middle of the page!

Resolution

- Large products (DIN A2 and larger): 100 to 150 dpi
- All other products: 300 to 356 dpi

Color

- Color mode: CMYK or gray scale, 8 bits/channel
- Maximum color application: 300 % standard, 350 % for advertising products
- Minimum color application: With a color coverage of less than 10 %, the color of the printed result can appear very weak.

Please note: 10 % yellow, for example, appears weaker than 10 % cyan.

- Color profile: ISO Coated v2 300 % (ECI) (obtainable at www.eci.org)
- In PDF data the color profile may only be created as an output intent
- The correct color profile for advertising products is "Europe ISO Coated FOGRA27"

Create black correctly

Black and gray objects such as texts or lines should always be created in pure black (e.g. cyan 0 %, magenta 0 %, yellow 0 %, black 60 % or cyan 0 %, magenta 0 %, yellow 0 %, black 100 %). Deep black such as cyan 40 %, magenta 0 %, yellow 0 %, black 100 % is not recommended for texts and lines, as matching inaccuracies can easily occur. A deep black can be achieved for black areas by adding other color components.

Depending on taste, other color components can be added until the maximum color application of the product is reached.

Line thicknesses

A thickness of at least 0.25 pt (0.09 mm) should be used for positive lines (dark line on light background) and at least 0.5 pt (0.18 mm) for negative lines (light line on dark background). Please note: Make sure the line thicknesses are not too small, especially when downsizing graphics.

If these instructions are not complied with, we cannot accept any liability for the printing result.

Orders received later than 14 days before the start of the event will be billed an express surcharge of 25 %, subject to a minimum surcharge of EUR 10 per order.

With our authorized signature below, we acknowledge acceptance of all items of the General and Special Terms of Business of NürnbergMesse and the General Terms of Business and the Special Conditions for Services of the ServicePartner.

Nuremberg, Germany
14–16.3.2017



embeddedworld2017

Exhibition&Conference
... it's a smarter world

Return to
NürnbergMesse GmbH
MesseService
Messezentrum
90471 Nürnberg
Tel +49 (0) 9 11. 86 06-80 00
Fax +49 (0) 9 11. 86 06-80 01
messe-service@nuernbergmesse.de

Contractor *
Blumen Kuhn FloralDesign GmbH
Kirchenweg 36
90419 Nürnberg
Tel +49 (0) 9 11. 33 01 69
Fax +49 (0) 9 11. 20 94 83
messe@blumenkuhn.de
www.blumenkuhn.de

Company _____

Street _____

Postcode, Town, Country _____

Tel _____

Fax _____

E-mail _____

Return deadline **Hall/Stand**
6.3.2017

Person to contact _____

Tel _____

Fax _____

Invoice address (only if different) _____

Order

VAT ID number of exhibitor:

1. Rental plants

EUR Quantity

(approx. 500 rental plants in own nursery!)

Please see our Internet site for more information and illustrated examples

• Ficus 100 cm – 220 cm	24.50 to 82.40	_____
• Areca/Kentia 140 – 220 cm	33.40 to 96.50	_____
• Dracaena 130 – 170 cm	26.30 to 49.30	_____
• Box rounds and pyramids	24.80 to 69.90	_____
• Round laurel's		
with and without stem 60 cm – 220 cm	42.90 to 129.30	_____
• Laurel pyramids/columns 150 – 230 cm	48.80 to 115.90	_____
• Bamboo 80 cm – 450 cm	35.00 to 125.00	_____
• Olives 150 cm – 320 cm	59.00 to 143.30	_____
• Citrus 140 – 160 cm	89.00 to 185.00	_____
• Phoenix palms 140 – 250 cm	49.90 to 117.30	_____
• Chamaerops palms		
single-stemmed/multi-stemmed 480 cm	195.00 to 275.00	_____
• Conifers of various sizes	on request	_____
• Sansevieria in high container approx. 80/100 cm	à 53.00	_____
• Sansevieria in high container approx. 120/140 cm	à 89.00	_____
• Zamioculcas in high container approx. 100/120 cm	à 62.10	_____
• Zamioculcas in high container approx. 140 /150 cm	à 98.00	_____
• Fern in high container approx. 100/120 cm	à 59.00	_____
• Fern in high container approx. 140/150 cm	à 89.90	_____

Other plants on request!

2. Containers and accessories for rental

“modern and smart”

• High container silver or white, square conical		
• 30 x 30 x 56 cm overall height with plant 90 – 200 cm	15.90	_____
• 40 x 40 x 75 cm overall height with plant 100 – 230 cm	26.50	_____
• 50 x 50 x 95 cm overall height with plant 130 – 300 cm	36.50	_____

Other containers on request!

“Always suitable”

• Plastic container, white or silver		
Ø 28 – Ø 70 cm	6.20 to 30.90	_____
• Moss and stone coverings depending on size	3.10 to 15.90	_____

Containers for rental may show signs of use.

New containers for rental on request for an additional charge.

3. Rental stand decoration

EUR Quantity

Please see our Internet site for more information and illustrated examples

• Flower beds, with film underlay, without edging, filled with plant compost and planted with foliage/flowering plants per m ²	60.00 to 120.00	_____
• Room divider 100 x 40 x 50 cm including low or high design for rental	200.00 to 375.00	_____
• Room divider 80 x 30 x 40 cm including low or high design for rental	160.00 to 280.00	_____
• Floral arrangement for standing on floor with fresh-cut flowers, foliage, accessories		
Standard approx. 120/150 cm overall height	100.00	_____
Business approx. 160/180 cm overall height	150.00	_____
Premium approx. 200/250 cm overall height	200.00	_____

4. Stand decoration for purchase, including container

Please see our Internet site for more information and illustrated examples

• Bowl of plants or plants in modern container designed for counter or sideboard		
Standard	35.00	_____
Business	65.00	_____
Premium	95.00	_____
• Floristic arrangement, in modern container for counter or sideboard round or oblong		
Standard	35.00	_____
Business	65.00	_____
Premium	95.00	_____
• Floristic arrangement, in modern container for conference table or lounge table round or oblong		
Standard	15.00	_____
Business	25.00	_____
Premium	35.00	_____
• Floristic arrangement for standing table		
Standard	7.50	_____
Business	15.00	_____
Premium	20.00	_____

Other sizes on request!

* If necessary, NürnbergMesse is entitled to have the service ordered provided by another ServicePartner. In this case, the customer will be notified of the other ServicePartner in good time.

With our authorized signature below, we acknowledge acceptance of all items of the General and Special Terms of Business of NürnbergMesse and the General Terms of Business and the Special Conditions for Services of the ServicePartner.

Place and date

Company stamp and authorized signature

5. Service

- Watering service for plants for rental or arrangements during the exhibition, per plant EUR 5.20
- Decorations of your exhibits in available showcases or similar on request
- Marketing campaigns, e.g., flowers for handout action with logo tag on request
- Fleurop service – Fleurop business service on request
- We deliver worldwide! "Bouquets for presentation" on request.

We will be pleased to consider your individual design and budget specifications. Prices including delivery to exhibition stand and collection of the rented goods.

7. Visual

Floristic arrangements for purchase:

Other colors and sizes on request! (containers may vary) **Quantity**

	Tropical strelitzia Strelitzia arrangement in glass vase	EUR 75.00 _____
	Exotic heliconia and anthurium Exotic heliconia and anthurium arrangement	EUR 70.00 _____
	Heliconia in bowl Heliconia modern design in bowl	EUR 89.00 _____
	Modern orchid Modern orchid	EUR 55.00 _____
	Calla in glass vase Calla in glass vase – simple and beautiful	EUR 95.00 _____
	Calla inside Calla inside	EUR 120.00 _____

6. Your requirements

Colors: _____

Type of design: (natural , modern, puristic, rustic) _____

Other: _____

Floristic arrangements for purchase:

Other colors and sizes on request! (containers may vary) **Quantity**







	Calla in glass vase	at EUR 45.00 _____
	Orchids chic and modern	at EUR 30.00 _____
	Calla innovativ	at EUR 15.00 _____
	Protea Nutans	at EUR 10.00 _____
	Sunflower in summer time alternative with yellow gerbera	at EUR 12.00 _____
	Anthurie exotisch	at EUR 15.00 _____

With our authorized signature below, we acknowledge acceptance of all items of the General and Special Terms of Business of NürnbergMesse and the General Terms of Business and the Special Conditions for Services of the ServicePartner.

Place and date _____







Company stamp and authorized signature _____

Floristic arrangements – including container – for rental:

Other colors and sizes on request!	Quantity
 <p>Elegant calla</p> <p>Elegant calla Container on column</p>	EUR 190.00 _____
 <p>Calla only</p> <p>Calla only in high container, white overall height approx. 150/160 cm</p>	EUR 190.00 _____
 <p>Parallel calla</p> <p>Parallel calla in white containers overall height approx. 120 cm per container design</p>	EUR 110.00 _____
 <p>Modern strelitzia</p> <p>Modern strelitzia in high container overall height approx. 180/200 cm</p>	EUR 155.00 _____
 <p>Heliconia graphic</p> <p>Heliconia graphic</p>	EUR 175.00 _____
 <p>Guzmania tropical</p> <p>Guzmania tropical</p>	EUR 250.00 _____

Plants for rental:

Approx. 500 rental plants to choose from – see also www.blumenkuhn.de. Here is a selection from the assortment. Other sizes and variable container available. We will be pleased to consider your individual design and budget on request. **Quantity**

 <p>Ficus benjamina</p> <p>Ficus benjamina with decorative pot approx. 180/200 cm (for rental)</p>	EUR 74.80 _____
 <p>Kentia palm</p> <p>Kentia palm with decorative pot approx. 180/200 cm (for rental)</p>	EUR 77.80 _____
 <p>Bamboo</p> <p>Bamboo with decorative pot approx. 200/240 cm (for rental)</p>	EUR 82.10 _____
 <p>Laurel pyramid</p> <p>Laurel pyramid with decorative pot approx. 150/160 cm (for rental)</p>	EUR 62.20 _____
 <p>Olive</p> <p>Olive with decorative pot approx. 250/320 cm (for rental)</p>	EUR 143.30 _____
 <p>Chamaerops palm</p> <p>approx. 450/550 cm with decorative pot (for rental)</p>	à EUR 275.00 _____
 <p>Sansevieria cylindrica</p> <p>Sansevieria cylindrica in high-quality container with stone covering per container 150/160 cm (for rental)</p>	EUR 189.00 _____

With our authorized signature below, we acknowledge acceptance of all items of the General and Special Terms of Business of NürnbergMesse and the General Terms of Business and the Special Conditions for Services of the ServicePartner.

Place and date _____

Company stamp and authorized signature _____

8. Floral stand design – Complete packages

Please order the single plant/arrangement at the stated prices or order the complete package with a "pre-order discount".

1. Modern & Innovative!



- 2 pyramid laurels in high containers, approx. 180 cm (for rental)
- 1 round laurel without stem in high container, approx. 40/60 cm diameter (for rental)
- 1 counter arrangement (for purchase)
- 3 arrangements for tables and shelves (for purchase)

at EUR 69.30
at EUR 57.90
at EUR 41.40
at EUR 10.40

~~EUR 269.10~~

Special price EUR 260.00

2. Puristic & Formal!



- 2 sansevierias in high containers, approx. 80/100 cm (for rental)
- 2 bowls of plants in low design (for purchase)
- 1 arrangement in high design (for purchase)
- 1 table arrangement (for purchase)

at EUR 53.00
at EUR 25.90
at EUR 51.80
at EUR 13.00

~~EUR 222.60~~

Special price EUR 215.00

3. Bamboo scene!



- 4 bamboos in dec. pots, approx. 200 cm (for rental)
- 1 counter arrangement (for purchase)
- 2 table arrangements (for purchase)

at EUR 75.35
at EUR 88.00
at EUR 10.40

~~EUR 410.20~~

Special price EUR 398.00

4. Tropical & Smart!



- 2 kentia palms in high con., approx. 220 cm (for rental)
- 2 zamioculcas in high containers with moss covering, approx. 100 cm (for rental)
- 1 counter arrangement (for purchase)

at EUR 95.90
at EUR 62.10
at EUR 36.30

~~EUR 352.30~~

Special price EUR 340.00

5. Classic White & Green!



- 1 kentia palm in tall container, solitaire, approx. 220 cm (for rental)
- 1 kentia palm in tall container, approx. 150 cm (for rental)
- 1 floral arrangement in rental container, for standing on floor, small version (for purchase)
- 2 counter arrangements (for purchase)

at EUR 95.90
at EUR 63.00
at EUR 98.40
at EUR 13.00

~~EUR 283.30~~

Special price EUR 275.00

6. AsienFlair!



- 1 bamboo with decorative pot, approx. 200 cm (for rental)
- 1 arrangement in rental container with rental pedestal total height approx. 100 cm

at EUR 75.40
at EUR 82.80

~~EUR 158.20~~

Special price EUR 150.00

Containers for rental may show signs of use. New containers for rental on request for an additional charge.

Prices including delivery to exhibition stand and collection of the rented good. We will be pleased to prepare other offers for individual stand arrangements or floral decoration for rented rooms.

Large selection of plants, special sizes and individual containers on request. The exhibitor is responsible for rental plants and containers until collection by the ServicePartner.

The ServicePartner settles accounts at least on delivery. Credit card payment on request.

Please state the correct company name and details in the invoice address. An extra fee of EUR 25 will be charged for issuing an invoice with a new address.

The order may be canceled up to eight days before the start of the exhibition. After that, the full price for the pre-ordered goods will be billed.

All orders will be delivered in good time so that the ordered goods are available before the start of the event.

All prices plus VAT.

Please fill in for payment by credit card:

Issuer : MasterCard VISA American Express

Card no.: : _____ / _____ / _____

Card verification no.: (The last 3 digits next to the signature on the back of the card or for AMEX 4 digits on the front)

Expiry date : _____

Holder of card: _____

We authorize Blumen Kuhn Floral design GmbH to debit the invoice amount from the above-mentioned credit card.

Signature: _____



With our authorized signature below, we acknowledge acceptance of all items of the General and Special Terms of Business of NürnbergMesse and the General Terms of Business and the Special Conditions for Services of the ServicePartner.

Place and date

Company stamp and authorized signature

Nuremberg, Germany
14-16.3.2017



embeddedworld2017

Exhibition&Conference
... it's a smarter world

Return to
NürnbergMesse GmbH
MesseService
Messezentrum
90471 Nürnberg
Tel +49 (0) 9 11. 86 06-80 00
Fax +49 (0) 9 11. 86 06-80 01
messeservice@nuernbergmesse.de

Contractor *
Gartengestaltung & Service Ronald Grabinger
Trierer Straße 52
90469 Nürnberg
Tel +49 (0) 9 11. 86 06-52 17
Fax +49 (0) 9 11. 86 06-64 39
Mobil 01 51. 11 71 90 71
info@grabinger-gartenservice.de

Return deadline
6.3.2017

Hall/Stand

Company _____

Street _____

Postcode, Town, Country _____

Tel _____

Fax _____

E-mail _____

Person to contact _____

Tel _____

Fax _____

Invoice address (only if different) _____

Order (price examples for floral stand design on the reverse side)

VAT ID number of exhibitor:

Ficus Benjamina in high container	Quantity
 30 x 30 x 56 cm (overall height approx. 120-150 cm) Rental price	EUR 52.80 ____
40 x 40 x 75 cm, overall height approx. 160-200 cm Rental price	EUR 68.50 ____

Ficus Benjamina in decorative pot	Quantity
 approx. 100-130 cm h Rental price	EUR 32.40 ____
approx. 150-170 cm h Rental price	EUR 48.60 ____
approx. 180-200 cm h Rental price	EUR 61.00 ____

Kentia/areca palm package in high container & counter arrangement	Quantity
 (overall height approx. 120-150 cm) rental prices per unit & counter arrangement with anthurium Rental price	at EUR 55.00 ____
Package price	EUR 39.90 ____
	EUR 135.00 ____

Kentia/areca palm in decorative pot	Quantity
 approx. 100-130 cm h Rental price	EUR 32.40 ____
approx. 155-170 cm h Rental price	EUR 48.60 ____
approx. 180-200 cm h Rental price	EUR 65.00 ____

Laurel package	Quantity
 3 laurel elements Columns/high stem approx. 155 h Rental prices per unit	at EUR 45.10 ____
& 2 round laurels in high containers at rental prices per unit (overall height approx. 90 cm) Package price	at EUR 54.00 ____
	EUR 233.00 ____

Round laurels with or without stem	Quantity
 Round laurel with high stem approx. 45 cm diameter, approx. 160 cm h Rental price	EUR 43.10 ____
Round laurel without stem approx. 30-40 or 50-60 cm D. Rental price	or EUR 55.00 ____

Bamboo	Quantity
 approx. 100 cm high Rental price	EUR 32.00 ____
approx. 200 cm high Rental price	EUR 60.00 ____

Box/laurel column	Quantity
 (overall height approx. 50 cm) Rental price	EUR 35.00 ____
(overall height approx. 120 cm) Rental price	EUR 49.00 ____
(overall height approx. 180-200 cm h) Rental price	EUR 85.00 ____

* If necessary, NürnbergMesse is entitled to have the service ordered provided by another ServicePartner. In this case, the customer will be notified of the other ServicePartner in good time.







With our authorized signature below, we acknowledge acceptance of all items of the General and Special Terms of Business of NürnbergMesse and the General Terms of Business and the Special Conditions for Services of the ServicePartner.

Place and date _____

Company stamp and authorized signature _____

Selection from range

Rental plants:

<p>Zamioculcas</p>  <p>In high container 30 x 30 x 56 cm (overall height approx. 80 cm) Rental price</p> <p>In high container 40 x 40 x 75 cm (overall height approx. 130 cm) Rental price</p>	<p>Quantity</p> <p>EUR 45.00 _____</p> <p>EUR 60.00 _____</p>	<p>Sansevieria</p>  <p>In high container 30 x 30 x 56 cm (overall height approx. 80 cm) Rental price</p> <p>Im Hochgefäß 40 x 40 x 75 cm (Gesamthöhe ca. 130 cm) Rental price</p>	<p>Quantity</p> <p>EUR 45.00 _____</p> <p>EUR 60.00 _____</p>
<p>Conference/standing table</p>  <p>Orchid bloom and foliage in glass cube with gravel, Rental price Desired color(s): _____</p>	<p>EUR 9.80 _____</p>	<p>Conference/standing table</p>  <p>Arrangement with seasonal blossoms, foliage and accessories Rental price Desired color(s): _____</p>	<p>EUR 26.50 _____</p>
<p>Conference/standing table</p>  <p>Gerbera with foliage and accessories in narrow vase Rental price Desired color(s): _____</p>	<p>EUR 9.90 _____</p>	<p>Conference/standing table</p>  <p>Arrangement with seasonal blossoms, foliage and accessories Rental price Desired color(s): _____</p>	<p>EUR 26.50 _____</p>
<p>Conference/standing table</p>  <p>One blossom as requested and in season with grass and decorative gravel in round glass container (approx. 10 cm D.) Rental price Desired color(s): _____</p>	<p>EUR 15.10 _____</p>	<p>Counter/sideboard</p>  <p>Orchid in glass – ceramic container simple design, Rental price Desired color(s): _____</p>	<p>EUR 39.90 _____</p>
<p>Counter/sideboard</p>  <p>Orchid panicle with accessories in glass or ceramic container (cymbidium) (height approx. 30 cm – oblong) Rental price Desired color(s): _____</p>	<p>EUR 57.90 _____</p>	<p>Counter/sideboard</p>  <p>Callas, lucky bamboo, blue orchid panicles and accessories in round glass container Rental price Desired color(s): _____</p>	<p>EUR 56.90 _____</p>
<p>Counter/sideboard</p>  <p>Gerberas and seasonal blossoms with accessories in a simple ceramic container (approx. 35 cm h) Rental price Desired color(s): _____</p>	<p>EUR 45.40 _____</p>	<p>Counter/sideboard</p>  <p>Gerberas or chrysanthemums with accessories in simple ceramic container (approx. 50 cm h) Rental price Desired color(s): _____</p>	<p>EUR 49.50 _____</p>



Selection from range

Rental plants:

Counter/sideboard	Quantity	Floor arrangement	Quantity
 <p>Anthurium and accessories in wood container (height approx. 60 cm) Rental price _____ Desired color(s): _____</p>	EUR 85.90 _____	 <p>Chrysanthemums, gerberas, and accessories in low container (overall height approx. 100 cm) Rental price _____ Desired color(s): _____</p>	EUR 149.00 _____
 <p>Callas, anthurium, lucky bamboo and accessories in ceramic container (height approx. 60 cm) Rental price _____ Desired color(s): _____</p>	EUR 49.95 _____	 <p>Callas, gerberas, chrysanthemums, and accessories in low container (overall height approx. 100 cm) Rental price _____ Desired color(s): _____</p>	EUR 149.00 _____
 <p>Callas and accessories in high container (overall height approx. 100 cm) Rental price _____ Desired color(s): _____</p>	EUR 60.00 _____	 <p>Anthurium, gerberas, and accessories in high container, for rental, overall height approx. 110 cm Rental price _____ Desired color(s): _____</p>	EUR 125.00 _____
 <p>approx. 300 cm overall height Rental price _____</p>	EUR 150.00 _____	 <p>Brown heliconia, gerberas, agave, and accessories in low container, for rental (overall height approx. 100 cm) Rental price _____ Desired color(s): _____</p>	EUR 149.00 _____
 <p>approx. 250-300 cm overall height Rental price _____</p>	EUR 150.00 _____	 <p>approx. 400 cm overall height Rental price _____</p>	EUR 250.00 _____
 <p>3-stemmed approx. 300 cm overall height approx. 350 cm h approx. 400 cm h Rental price _____</p>	EUR 180.00 _____	 <p>(approx. 50 cm overall height) Rental price _____ (approx. 150-180 cm overall height) Rental price _____</p>	EUR 35.00 _____ EUR 75.00 _____

Selection from range

Rental plants:

	Quantity
<p>Solitaire thuja topiaries</p>  <p>approx. 200 cm h Rental price</p>	EUR 80.00 _____
<p>High container in various sizes</p>  <p>30 x 30 x 56 cm white/silver Rental price</p> <p>40 x 40 x 75 cm white/silver Rental price</p>	EUR 15.00 _____ EUR 25.00 _____

	Quantity
<p>Decorative pot in various sizes</p>  <p>(shapes may vary) white/silver approx. 30 cm diameter Rental price</p> <p>approx. 45 cm diameter Rental price</p>	EUR 7.50 _____ EUR 10.00 _____

Accessories and other:

Covering stones for rental plants per plant	EUR 5.00 _____
Moss covering for rental plants per plant	EUR 3.00 _____
Sisal or bast for rental plants per plant	EUR 3.00 _____
Watering service for plants or arrangements needing plenty of water, e.g., bamboo, during the exhibition	EUR 5.20 _____
Automatic replacement service for fresh-cut flowers daily or after two days	on request
Decoration of showcases, etc., floral and non-floral	on request
Bouquets for presentation, depending on type	on request

Please let us know your special requirements!

We will be pleased to prepare other offers for individual stand arrangements or floral decoration for rented rooms. Large selection of plants, special sizes and individual containers on request. Please state the desired colors for floral arrangements and flowering plants! All prices for the rental plants include delivery and collection. The exhibitor is responsible for rental plants and containers until collection by the ServicePartner.

The ServicePartner settles accounts in advance per invoice or on delivery. The following credit cards are accepted: MasterCard, American Express, VISA. Please state the correct company name and details in the invoice address. An extra fee of EUR 25 will be charged for issuing an invoice with a new address.

All prices plus VAT at the statutory rate.

The ServicePartner is available in the service areas of the respective halls until the evening of the start of the event or can be reached by telephone for placing orders.

For invoices totaling EUR 250 or more, we grant a 2 % discount payable within ten days.

However, the order must be placed in writing 20 day before the start of the event. Stated package prices are excluded.

Mit unserer rechtsverbindlichen Unterschrift erkennen wir die Allgemeinen und Besonderen Geschäftsbedingungen der NürnbergMesse sowie die Allgemeinen Geschäftsbedingungen und Besonderen Servicebedingungen des ServicePartners voll umfassend an.

The examples shown here are mainly large solitaire plants. Smaller sizes of plants are possible at any time (see first page). Other illustrations can be found in the stand configurator gallery at www.standconfigurator.com or on the home page: www.grabinger-gartenservice.de
We will be pleased to advise you individually on your floral stand design.
All prices are the rental charges for the event and are subject to the addition of VAT at the statutory rate.
The exhibitor is responsible for rental plants and containers until collection by the ServicePartner.

Please fill in for payment by credit card:

Issuer : MasterCard VISA American Express

Card no.: : _____ / _____ / _____ / _____

Card verification no.: (The last 3 digits next to the signature on the back of the card or for AMEX 4 digits on the front)

Expiry date : _____

Holder of card: _____

We authorize Gartengestaltung & Service Ronald Grabinger to debit the invoice amount from the above-mentioned credit card.

Signature: _____

Nuremberg, Germany
14-16.3.2017



embeddedworld2017

Exhibition & Conference
... it's a smarter world

Return to
NürnbergMesse GmbH
MesseService
Messezentrum
90471 Nürnberg
Tel +49 (0) 9 11. 86 06-80 00
Fax +49 (0) 9 11. 86 06-80 01
messeservice@nuernbergmesse.de

Contractor *
Gartengestaltung & Service Ronald Grabinger
Trierer Straße 52
90469 Nürnberg
Tel +49 (0) 9 11. 86 06-52 24
Fax +49 (0) 9 11. 86 06-64 39
Mobile phone 01 51. 11 71 90 78
info@grabinger-gartenservice.de

Return deadline
13.2.2017

Hall/Stand

Company _____

Street _____

Postcode, Town, Country _____

Tel _____

Fax _____

E-mail _____

Person to contact _____

Tel _____

Mobile phone _____

Fax _____

Order

Indoor area

EUR Quantity

1. Turf

1.1 Delivery and laying of turf and removal at the end of the event without wooden fringe/without construction foil per m² 28.20 _____

1.2 Delivery and mantling of wooden fringe per m on request _____

1.3 Delivery and laying of construction foil per m² on request _____

2. Arranging flowerbeds with foliage and flowering outdoor plants and summer flowers, possibly with boulder up to max. diameter of 0.40 m. Lining with plastic sheeting and filling with soil. Without side borders. per m² on request _____

3. Natural stone and cast stone covering professionally laid including pointing (for laying natural stone coverings provided by exhibitor). per m² on request _____

Cast stone coverings, provided by exhibitor (interlocking bricks or garden slabs) per m² on request _____

Material supplied by ServicePartner on request. Please ask for prices.

Please fill in for payment by credit card:

Issuer : MasterCard VISA American Express

Card no. : _____ / _____ / _____

Card verification no. : (The last 3 digits next to the signature on the back of the card or for AMEX 4 digits on the front)

Expiry date : _____

Holder of card: _____

We authorize Gartengestaltung & Service Ronald Grabinger to debit the invoice amount from the above-mentioned credit card.

Signature: _____

* If necessary, NürnbergMesse is entitled to have the service ordered provided by another ServicePartner. In this case, the customer will be notified of the other ServicePartner in good time.

With our authorized signature below, we acknowledge acceptance of all items of the General and Special Terms of Business of NürnbergMesse and the General Terms of Business and the Special Conditions for Services of the ServicePartner.

VAT ID number of exhibitor:

Outdoor area

EUR Quantity

1. Tents for events and for protection of exhibitor's machinery and equipment. Minimum rental period 3 days Maximum size 100 m² on request

2. Delivery and erection of flag-poles, including drilling into ground and dismantling at the end of the event Aluminum flag-poles height 10 m/each 170.00 _____

3. Erection of existing flag-poles, including drilling into ground each 65.00 _____

4. Drilling holes for flag-poles each 29.50 _____

5. Delivery of bulk material and removal at the end of the event. Material, e.g. sand, grit, ballast and soil in various grain sizes per m³ 64.00 _____

6. Hourly rates, e.g. for spreading bulk material Skilled laborer per hour 41.20 _____
Wheeled loader per hour 86.60 _____

Other hourly rates on request.

7. Mobile fences: delivery, mounting and fixing – dismantling and pick-up after exhibition. Length: 3.50 m/height: 1.50-1.80 m each 47.25 _____

8. Demarcation barriers: delivery, mounting and fixing – dismantling and pick-up after exhibition. Length: 2.50 m/height: 1.10 m each 21.00 _____

Other offers for individual design and delivery of material on request. The exhibitor is responsible for the rented objects until their removal by the ServicePartner.

All prices plus VAT at the statutory rate.

Cancellations are only possible up to 10 days before the official assembly date. The services ordered will be billed if cancelled later.

Complaints concerning the extent of services charged are to be checked and reported to the ServicePartner before dismantling the stand. Complaints cannot be accepted after the event because there is no possibility of properly checking the services provided.

A last-minute surcharge of 25 % may be billed for orders received 7 days or less before the start of the event.

Place and date

Company stamp and authorized signature

Nuremberg, Germany
14–16.3.2017



embeddedworld2017

Exhibition&Conference

... it's a smarter world

Company

Street

Postcode, Town, Country

Tel

Fax

E-mail

Return to
NürnbergMesse GmbH
MesseService
Messezentrum
90471 Nürnberg
Tel +49 (0) 9 11. 86 06-80 00
Fax +49 (0) 9 11. 86 06-80 01
messeservice@nuernbergmesse.de

Contractor *
SAG GmbH
ServicePartnerCenter
Messezentrum
90471 Nürnberg
Tel +49 (0) 9 11. 81 88 18-0
Fax +49 (0) 9 11. 81 88 18-19
sag-messe@sag.eu

Return deadline
10.1.2017

Hall/Stand

Person to contact

Tel

Fax

Invoice address (only if different)

Order

Payment of the services ordered is due immediately on receipt of the invoice, which will be issued before the start of the event!

- 1. Main supply** EUR
- 1.1 up to 3 kW (230 V / 16 A), including safety socket, earth-leakage circuit-breaker (**Art. 1010010**) 126.90
- 1.2 up to 3 kW (230 V / 16 A), including 3-way safety socket, earth-leakage circuit-breaker (**Art. 1010020**) 144.90
- 1.3 up to 2 x 3 kW (2 x 230 V / 16 A), including 2 safety sockets, 2 earth-leakage circuit-breakers (**Art. 1010030**) 190.50
- 1.4 up to 9 kW (230 V / 400 V), including 1 CEE coupler 16 A (**Art. 1020020**) and distribution panel type 1 if required yes no expected load rating in kW _____ 321.90
- 1.5 up to 20 kW (230 V / 400 V), including 1 CEE coupler 32 A (**Art. 1020040**) and distribution panel type 2 if required yes no expected load rating in kW _____ 471.50
- 1.6 up to 40 kW (230 V / 400 V), including 1 CEE coupler 63 A, 1 safety socket, fuses and earth-leakage circuit-breaker (**Art. 1020060**) expected load rating in kW _____ 744.90
- 1.7 up to 83 kW (230 V / 400 V), including 1 CEE coupler 125 A, metering necessary in separate sub-distributor (**Art. 1020090**) expected load rating in kW _____ 1,735.00
- 1.8 up to 130 kW (230 V / 400 V), with unterminated cable ends, metering necessary in separate sub-distributor (**Art. 1020110**) expected load rating in kW _____ 2,855.50
- 1.9 connections rated above 130 kW and outdoor connections charged according to outlay (**Art. 1030120**) on request

- 2. Distribution panel from main supply** EUR
incl. installation, dismantling and rental fee (from Item 1.4)
- 2.1 distribution panel type 1 (1 pc. included in Item 1.4 if required) up to 9 kW with 2 earth-leakage circuit-breakers and 4 safety sockets, 1 CEE socket 16 A, 5-poles (**Art. 1120010**) 128.10
- 2.2 distribution panel type 2 (1 pc. included in Item 1.5 if required) up to 20 kW with earth-leakage circuit-breaker and trip fuses, 6 safety sockets and 2 CEE sockets 16 A, 5-poles, with 3-pole 16 A trip fuses (**Art. 1120020**) 191.70
- 2.3 distribution panel type 3 up to 40 kW with trip fuses, 14 safety sockets and 2 CEE sockets 16 A, 5-poles (**Art. 1120030**) 220.90

* If necessary, NürnbergMesse is entitled to have the service ordered provided by another ServicePartner. In this case, the customer will be notified of the other ServicePartner in good time.

With our authorized signature below, we acknowledge acceptance of all items of the General and Special Terms of Business of NürnbergMesse and the General Terms of Business and the Special Conditions for Services of the ServicePartner.

VAT ID number of exhibitor:

--	--	--	--	--	--	--	--	--	--	--	--	--	--	--	--	--	--	--	--	--	--	--

- 2.4 distribution panel type 4 up to 40 kW with 4 trip fuses and 4 CEE sockets 32 A, 5-poles (**Art. 1120040**) 220.90 EUR
- 2.5 distribution panel type 5 up to 83 kW with trip fuses, 2 CEE sockets 63 A and 6 CEE sockets 32 A (**Art. 1120050**) 296.00
- 2.6 distribution panel rated above 83 kW (**Art. 1120060**) on request
- 2.7 hourly rate for fitter including all surcharges 42.90
- 2.8 hourly rate for master craftsman/technician including all surcharges 64.80

3. Lighting

see order form for Accessories for suspension + lighting S2.17

4. Electricity fee

- 4.1** Please let us know which kind of electrical energy you require! (If information is missing we will invoice green electricity)
- 4.2 Flat-rate charge for electricity fee for green electricity** EUR/day
- 4.2.1 for main supply up to 3 kW (Item 1.1 – 1.2) 8.30
- 4.2.2 for main supply up to 6 kW (Item 1.3) 16.60
- 4.2.3 for main supply up to 9 kW (Item 1.4) 35.00
- 4.2.4 for main supply up to 20 kW (Item 1.5) 66.60
- 4.2.5 for main supply up to 40 kW (Item 1.6) 120.10
- 4.2.6 for main supply above 40 kW (Item 1.7 – 1.9) 271.00
a fixed daily fee of
The final amount based on the actual metered consumption (4.2.6) will be invoiced after the end of the event (kWh x EUR 0.51/kWh). Any overpayment/underpayment will be refunded/charged as applicable.
- 4.3 Flat-rate charge for electricity fee for non green electricity** EUR/day
- 4.3.1 for main supply up to 3 kW (Item 1.1 – 1.2) 7.50
- 4.3.2 for main supply up to 6 kW (Item 1.3) 15.00
- 4.3.3 for main supply up to 9 kW (Item 1.4) 31.60
- 4.3.4 for main supply up to 20 kW (Item 1.5) 60.10
- 4.3.5 for main supply up to 40 kW (Item 1.6) 108.30
- 4.3.6 for main supply above 40 kW (Item 1.7 – 1.9) 244.40
a fixed daily fee of
The final amount based on the actual metered consumption (4.3.6) will be invoiced after the end of the event (kWh x EUR 0.46/kWh). Any overpayment/underpayment will be refunded/charged as applicable.

All prices in EURO plus VAT at the statutory rate.

Please submit a plan of the stand overleaf showing the position of the required connection points.

The stand will be wired by our own electricians

or our stand construction company: yes no

We use a raised floor with a height of _____ mm yes no

Electrical grounding of stand is required (metal stand): yes no

by SAG see item 5.15

by our own electricians or our stand construction company

Place and date

Company stamp and authorized signature

Electricity supply

Order (continued)

5. Stand installation / rental of material

EUR

Installation, dismantling and rental fee from main supply		
<input type="checkbox"/> 5.1	cable Cat 6 with RJ45 plug at each end (Art. 1150010)	piece @ 75.40
<input type="checkbox"/> 5.2	safety socket 230 V / 16 A, in various lengths (Art. 1050020)	piece @ 34.80
<input type="checkbox"/> 5.3	safety socket 230 V / 16 A, 3-way, in various lengths (Art. 1050030)	piece @ 41.00
<input type="checkbox"/> 5.4	CEE socket up to 400 V / 16 A, 5-pole, in various lengths (Art. 1050040)	piece @ 51.90
<input type="checkbox"/> 5.5	CEE socket up to 400 V / 32 A, 5-pole, in various lengths (Art. 1050050)	piece @ 62.00
<input type="checkbox"/> 5.6	CEE socket up to 400 V / 63 A, 5-pole, in various lengths (Art. 1050060)	piece @ 72.00
<input type="checkbox"/> 5.7	CEE socket up to 400 V / 125 A, 5-pole, in various lengths (Art. 1050070)	piece @ 122.20
<input type="checkbox"/> 5.8	adapter, input CEE 16 A, 5-pole, output 3 x safety sockets, 3-pole, 230 V (Art. 1150080)	piece @ 14.50
<input type="checkbox"/> 5.9	adapter, input CEE 16 A, 5-pole, 400 V, output CEE 32 A, 5-pole, 400 V (Art. 1150090)	piece @ 21.30
<input type="checkbox"/> 5.10	adapter, input CEE 32 A, 5-pole, 400 V, output CEE 16 A, 5-pole, 400 V, with 16 A fuse (Art. 1150100)	piece @ 43.90
<input type="checkbox"/> 5.11	adapter, input CEE 32 A, 5-pole, 400 V, output CEE 63 A, 5-pole, 400 V (Art. 1150110)	piece @ 48.70
<input type="checkbox"/> 5.12	adapter, input CEE 63 A, 5-pole, 400 V, output CEE 125 A, 5-pole, 400 V (Art. 1150120)	piece @ 90.00
<input type="checkbox"/> 5.13	CEE cross coupler, input CEE 16 A, 5-pole, 400 V, output 3 x CEE 16 A, 5-pole, 400 V (Art. 1150130)	piece @ 29.90
<input type="checkbox"/> 5.14	CEE cross coupler, input CEE 32 A, 5-pole, 400 V, output 3 x CEE 32 A, 5-pole, 400 V (Art. 1150140)	piece @ 40.90
<input type="checkbox"/> 5.15	Electrical grounding / equipotential bonding (Art. XXXXXXX)	piece @ 46.50

All prices in EURO plus VAT at the statutory rate.

Orders must be received by the organizer in a complete and correct form within the deadline set for the respective event. SAG GmbH is under no obligation to provide services for orders that do not meet these requirements. Orders for mains power connections, suspensions, truss and compressed air connections – in so far as SAG GmbH can still process such orders or changes to existing orders – will be subject – from 9 weeks prior to the event – to a surcharge by SAG GmbH of 25 %. Other articles/services will be subject – from 14 days prior to the event – to a surcharge of 25 % for services according to a fixed price and/or 50 % for services according to time expenditure.

Further information and the Special Conditions for Services of SAG GmbH for electricity supply can be found on our Internet site at www.sag-servicepartner.de.

Plan of electricity supply

Plan of stand showing exact position of electricity supply **Important! This plan is not for stand construction purposes!**

Adjacent stand no.: _____												

With our authorized signature below, we acknowledge acceptance of all items of the General and Special Terms of Business of NürnbergMesse and the General Terms of Business and the Special Conditions for Services of the ServicePartner.

Place and date _____

Company stamp and authorized signature _____

Nuremberg, Germany
14–16.3.2017



embeddedworld2017

Exhibition&Conference
... it's a smarter world

Return to
NürnbergMesse GmbH
MesseService
Messezentrum
90471 Nürnberg
Tel +49 (0) 9 11. 86 06-80 00
Fax +49 (0) 9 11. 86 06-80 01
messeservice@nuernbergmesse.de

Company stamp:

Hall/Stand

Plan of stand showing exact position of electricity supply

Important! This plan is not for stand construction purposes!

Adjacent stand no.: _____															
Adjacent stand no.: _____															

Nuremberg, Germany
14–16.3.2017



embeddedworld2017

Exhibition&Conference
... it's a smarter world

Return to
NürnbergMesse GmbH
MesseService
Messezentrum
90471 Nürnberg
Tel +49 (0) 9 11. 86 06-80 00
Fax +49 (0) 9 11. 86 06-80 01
messeservice@nuernbergmesse.de

Contractor *
SAG GmbH
ServicePartnerCenter
Messezentrum
90471 Nürnberg
Tel +49 (0) 9 11. 81 88 18-0
Fax +49 (0) 9 11. 81 88 18-19
sag-messe@sag.eu

Company _____

Street _____

Postcode, Town, Country _____

Tel _____

Fax _____

E-mail _____

Return deadline
10.1.2017

Hall/Stand _____

Person to contact _____

Tel _____

Fax _____

Invoice address (only if different) _____

Order

1. Suspension from hall roof

Attention:

Please mark the suspension points and any special services required on the enclosed stand plan!

Note:

The vertical loading capacity of suspension points is maximum 25 kg per point in halls 1, 2, 3, 4, 5, 6, 7, 8, 9, 10 and 12 and maximum 250 kg from fixed point in halls 3A, 4A, 7A and 11.0.

It is essential to state the weight per suspension point!

A higher load on the ceiling construction is possible in exceptional cases subject to compliance with various criteria. The additional costs for static calculations and installing of load monitoring are to be borne by the applicant. The necessary technical plans/documents are to be submitted to SAG GmbH in digitalized dwg format at least 6 weeks before the start of assembly.

A discount as stated below will be granted on request for 7 or more suspension points without power lead (except in halls 3A, 4A, 7A and 11.0), provided the order forms for "Suspension from hall roof" are submitted in a complete order with drawing, dimensions and weight per point (the drawing must show the contact details of the company appointed for the planning work and be marked as an implementation plan by the signature of the employee responsible) and technically correct state in good time (return deadline see above). The discount is cancelled if changes (e.g. place, height, weight ...) are made later than official deadline.

7–12 points 5 %, 13–20 points 10 %, 21–40 points 15 %, 41–60 points 20 %, from 61 points 25 %.

Mounting your exhibits (flags, trusses etc.) is not included in the price of suspension points.

Height of suspension point above hall floor _____ m

(Please note the maximum construction height determined by the organizer)

Type of suspension:

(e.g. flags, banners, trusses, lighting)

We order in accordance with the General Terms of Business and

Technical Guidelines of NürnbergMesse:

Hall 1, 2, 3, 4, 5, 6, 7, 8, 9, 10, 12

(max. vertical load per suspension point: 25 kg) **EUR / piece(s)**

- 1.1 suspension point consisting of 4 mm steel rope with open end and power lead rated at 3 kW from main supply 122.40 ___ piece(s)
- 1.2 suspension point consisting of 4 mm steel rope with power lead rated at 3 kW from main supply, including wire rope clamp for rental (info overleaf) 127.75 ___ piece(s)
- 1.3 suspension point without power lead, otherwise as per Item 1.1 107.50 ___ piece(s)
- 1.4 suspension point without power lead, otherwise as per Item 1.2 113.00 ___ piece(s)

VAT ID number of exhibitor:

--	--	--	--	--	--	--	--	--	--	--	--	--	--

Halls 3A, 4A, 7A and 11

(max. vertical load per suspension point: 250 kg) **EUR / piece(s)**

- 1.5 suspension point from pre-rigg or fixed point, consisting of steel rope up to 10 mm, with open end 208.00 ___ piece(s)
- 1.6 suspension point from pre-rigg or fixed point, consisting of steel rope up to 10 mm including wire rope clamp, for rental (info overleaf) 230.00 ___ piece(s)
- 1.7 power supply to suspension point from main supply up to 3 kW up to 9 kW 89.30 ___ piece(s) (from 9 kW on request)

2. Shading, trusses, hoisting for rental

Shading for light domes

- 2.1 in halls 1, 2, 4, 5, 6, 7, 8 and 9 106.50 ___ piece(s)
- 2.2 in halls 3, 3A and 7A 158.60 ___ piece(s)
- 2.3 installation of exhibitor's own material on request

Truss-systems

fixed to suspension points – see Item 1 including necessary assembly and dismantling

- 2.4 4-point truss (300 x 300 mm) 41.90 ___ m
- 2.5 shaped parts 300 x 300 mm (corner pieces, angle pieces etc.) 49.70 ___ piece(s) other trusses and shaped parts on request

Hoisting (in halls 3A, 4A, 7A and 11)

- 2.6 electric chain hoist D8+, 250 kg, lift 17 m, at existing suspension point (Item 1.6) 219.80 ___ piece(s)
- 2.7 motor controller for chain hoist motor (Item 2.6) 31.40 ___ @ channel
- 2.8 manual chain hoist, 500 kg, lift 8 m, at existing suspension point (Item 1.6), without assembly 59.60 ___ piece(s)
- 2.9 torque motor up to 250 kg with direction reverse and speed control from 0.8–5 rpm, including motor controller, at existing suspension point/system (Item 1.6) 319.20 ___ piece(s)

3. Work according to outlay

(fitter's hourly rate including all additional charges) **EUR / hour**

- 3.1 fitter 42.90 ___ per hour
- 3.2 fitter with hydraulic work platform 77.90 ___ per hour
- 3.3 master craftsman/technician 64.80 ___ per hour

4. Lighting

see order form for Accessories for suspension + lighting S2.17

All prices in EURO plus VAT at the statutory rate. The ordered services have to be paid after receiving the invoices without delay. Issuing the invoice could take place before start of the event.

* If necessary, NürnbergMesse is entitled to have the service ordered provided by another ServicePartner. In this case, the customer will be notified of the other ServicePartner in good time.

With our authorized signature below, we acknowledge acceptance of all items of the General and Special Terms of Business of NürnbergMesse and the General Terms of Business and the Special Conditions for Services of the ServicePartner.

Place and date _____

Company stamp and authorized signature _____

Special Conditions for Services provided by SAG GmbH (Suspension from hall roof)

Safety

1. The following types of suspension are not permitted for safety reasons:
 - Suspension points used for securing stand components or exhibits (stand components or exhibits must stand securely on their own)
 - Suspended constructions with a rigid or non-positive connection to the hall floor
2. Suspension constructions/points as far as the hand-over point may only be installed or changed by the responsible ServicePartner.
3. The use of lifting equipment (chain hoists, motor-driven chain hoists etc.) is prohibited in halls 1, 2, 3, 4, 5, 6, 7, 8, 9, 10 and 12. The use of such equipment in halls 3A, 4A, 7A and 11 must be approved by NürnbergMesse or SAG GmbH.
4. Use of wire rope clamps:
 - wire rope clamps are not suitable for use outdoors
 - ropes must not be damaged
 - the rope clamp must have noticeable spring pressure before use
 - to achieve full load capacity, the wire ropes must be free of grease, oil and rust
 - the rope end to be threaded through the clamp must be closed (tinned, shrink sleeve)
 - wire rope clamps may not be used singly (at least 2 points per object)

Wire rope clamps are used only for suspending static loads and are not suitable for moving, dynamic loads. To ensure maximum possible safety, it is recommended that several rope clamps are used for each suspended object and measures taken to prevent the object moving.

Any wire rope clamps ordered or required can be collected on payment of the rental charge and deposit from SAG GmbH in the ServicePartnerCenter (in the store opposite hall 7A) during our regular working times on the official assembly and dismantling days and returned there after use.

Any wire rope clamps missing or not returned will be charged to the person collecting at the following prices plus a processing fee of EUR 50.00:

- Type 50 SV at EUR 23.63/each – plus VAT at statutory rate
- Type 80 SV at EUR 59.46/each – plus VAT at statutory rate

A rental charge of EUR 10/month will be made for wire rope clamps returned after the end of the official dismantling period.

Wire rope clamp with lifting eye nut

Type M12 (for 4 mm steel rope)
Inside diameter of eye: 30 mm
Outside diameter of eye: 55 mm

Type M20 (6-8 mm steel rope)
Inside diameter of eye: 40 mm
Outside diameter of eye: 72 mm

Further technical information on request!

Technical details – important information

1. SAG GmbH will provide the suspension point for the exhibitor in the desired position above the stand space and inside the stand limits if structural conditions permit. The construction to be suspended must be located within the stand space. SAG GmbH will check the feasibility of the desired fixing points based on the documents submitted and reserves the right to have the suspension loads and the rig used inspected by a structural engineer. This inspection is subject to a fee, which will be charged to the exhibitor.
2. For the installation of suspension points, a plan of the stand is required which clearly shows the position of the stand in the hall and the exact position of each suspension point in the stand space together with its exact point load (plan with dimensions or to scale).
3. The maximum load capacity of each planned suspension point on the ceiling construction is 25 kg for halls 1, 2, 3, 4, 5, 6, 7, 8, 9, 10 and 12 and 250 kg in halls 3A, 4A, 7A and 11. If a suspension point ordered in halls 3A, 4A, 7A and 11 is not vertically below a fixed point, the suspension point will be provided by using a pre-rig connected between two or more fixed points.
4. Fixing the objects to be suspended (lighting trusses, spotlights, banners, flags, etc.) is the responsibility of the exhibitor, but can be carried out by SAG GmbH on request.
5. The power supply for the lighting system is always provided from the main supply of the stand.
6. The electrical requirement for lighting etc. is to be included in the main supply and ordered on Form S2.10.

Further information

NürnbergMesse GmbH reserves the right to request the installation of load measurement systems. The load measurement systems are to be supplied, installed and operated exclusively by SAG GmbH. Load measurement systems are provided at extra cost, which will be charged to the exhibitor.

Orders must be received by the organizer in a complete and correct form within the deadline set for the respective event. SAG GmbH is under no obligation to provide services for orders that do not meet these requirements. Orders for mains power connections, suspensions, truss and compressed air connections – in so far as SAG GmbH can still process such orders or changes to existing orders – will be subject – from 9 weeks prior to the event – to a surcharge by SAG GmbH of 25 %. Other articles/services will be subject – from 14 days prior to the event – to a surcharge of 25 % for services according to a fixed price and/or 50 % for services according to time expenditure.

Further information and more of the Special Conditions for Services of SAG GmbH for suspension from the hall roof are available for inspection on our Internet site at www.sag-servicepartner.de.

Nuremberg, Germany
14–16.3.2017

Company stamp:

Return to
 NürnbergMesse GmbH
 MesseService
 Messezentrum
 90471 Nürnberg
 Tel +49 (0) 9 11. 86 06-80 00
Fax +49 (0) 9 11. 86 06-80 01
 messeservice@nuernbergmesse.de



Hall/Stand

Plan of stand showing exact position(s) for mounting suspension points **Important: This plan is not for stand construction purposes!**

The total weight of our suspended loads is: _____ kg.

Point 1 (P1): _____ kg / Point 2 (P2): _____ kg / Point 3 (P3): _____ kg / Point 4 (P4): _____ kg / Point 5 (P5): _____ kg / Point 6 (P6): _____ kg ...

We will use the following attachment gear: _____

The plans submitted are to show the contact details of the company appointed for planning work and be marked as implementation plan by the signature of the employee responsible. (Please submit 3 copies of detailed plans for approval.)

Adjacent stand no.: _____	Adjacent stand no.: _____												

Please mark the following details on the plan:
 stand size (m²), type of stand (corner, head or in-line stand)
 and location of any cubicle + desired equipment

Scale 1: _____
 (1 : 100 – 1 m = 1 cm)
 (1 : 50 – 1 m = 2 cm)

With our authorized signature below, we acknowledge acceptance of all items of the General and Special Terms of Business of NürnbergMesse and the General Terms of Business and the Special Conditions for Services of the ServicePartner.

Place and date

Company stamp and authorized signature

Nuremberg, Germany
14–16.3.2017



embeddedworld2017

Exhibition&Conference
... it's a smarter world

Return to
NürnbergMesse GmbH
MesseService
Messezentrum
90471 Nürnberg
Tel +49 (0) 9 11. 86 06-80 00
Fax +49 (0) 9 11. 86 06-80 01
messe-service@nuernbergmesse.de

Contractor *
SAG GmbH
ServicePartnerCenter
Messezentrum
90471 Nürnberg
Tel +49 (0) 9 11. 81 88 18-0
Fax +49 (0) 9 11. 81 88 18-19
sag-messe@sag.eu

Company _____

Street _____

Postcode, Town, Country _____

Tel _____

Fax _____

E-mail _____

Return deadline
14.12.2016

Hall/Stand

Person to contact _____

Tel _____

Fax _____

Invoice address (only if different) _____

Order

Price including delivery, installation (connection / installation in existing systems – see also order form for Suspension from hall roof S2.15), initial operation, instructions, dismantling and collection

For safety reasons, lighting systems must only be installed on suitable stand components or components provided for this purpose.

1. ARRI fresnel spotlights

with softly defined light output,
rotating barn doors for light control

	EUR / piece
<input type="checkbox"/> 1.1 650 W (3.1 kg)	69.40 _____ piece
<input type="checkbox"/> 1.2 1000 W (6.0 kg)	75.90 _____ piece
<input type="checkbox"/> 1.3 2000 W (13.5 kg)	88.70 _____ piece

2. PAR spotlights

(Item 2.1 – 2.6 suitable for mounting on stand fascia/wall)

	EUR / piece
<input type="checkbox"/> 2.1 PAR 20, 75 W (1.1 kg), single installation	53.70 _____ piece
<input type="checkbox"/> 2.2 PAR 20, 75 W (1.1 kg) / from 5 pieces	30.10 _____ piece
<input type="checkbox"/> 2.3 PAR 20, 75 W (1.1 kg) / from 10 pieces	27.30 _____ piece
<input type="checkbox"/> 2.4 PAR 30, 75 W (0.7 kg), single installation	53.70 _____ piece
<input type="checkbox"/> 2.5 PAR 30, 75 W (0.7 kg) / from 5 pieces	30.10 _____ piece
<input type="checkbox"/> 2.6 PAR 30, 75 W (0.7 kg) / from 10 pieces	27.30 _____ piece
<input type="checkbox"/> 2.7 PAR 56, 300 W (1.4 kg)	59.90 _____ piece
<input type="checkbox"/> 2.8 PAR 56, 300 W (1.4 kg) / from 5 pieces	36.50 _____ piece
<input type="checkbox"/> 2.9 PAR 56, 300 W (1.4 kg) / from 10 pieces	33.70 _____ piece
<input type="checkbox"/> 2.10 PAR 64, 1000 W (1.7 kg)	69.40 _____ piece
<input type="checkbox"/> 2.11 PAR 64, 1000 W (1.7 kg) / from 5 pieces	46.60 _____ piece
<input type="checkbox"/> 2.12 PAR 64, 1000 W (1.7 kg) / from 10 pieces	43.70 _____ piece
<input type="checkbox"/> 2.13 PAR 64 / 6-bar, 6x500 W (17 kg)	158.00 _____ piece
<input type="checkbox"/> 2.14 8-light, 8x250 W (10 kg)	158.00 _____ piece
<input type="checkbox"/> 2.15 Outdoor PAR 64, 1000 W (6 kg)	75.80 _____ piece
<input type="checkbox"/> 2.16 LED-PAR AT3 Tri-Color, 18x3 W / (1.5 kg)	93.00 _____ piece

3. Multi-lens spotlights

Light power of a conventional spotlight with low power consumption

	EUR / piece
<input type="checkbox"/> 3.1 ML56, CDM, 190 W (7 kg)	75.80 _____ piece
<input type="checkbox"/> 3.2 ML64, GKV, 600 W (3.5 kg)	75.80 _____ piece

VAT ID number of exhibitor:

4. Area floodlights

(Item 4.11 – 4.15 suitable for mounting on stand fascia/wall)

	EUR / piece
<input type="checkbox"/> 4.1 wide-angle halogen lamp HQI, 150 W (4.5 kg)	74.70 _____ piece
<input type="checkbox"/> 4.2 wide-angle halogen lamp HQI, 150 W (4.5 kg) / from 5 pieces	54.40 _____ piece
<input type="checkbox"/> 4.3 wide-angle halogen lamp HQI, 150 W (4.5 kg) / from 10 pieces	51.50 _____ piece
<input type="checkbox"/> 4.4 wide-angle halogen lamp HQI, 400 W (13.2 kg)	118.00 _____ piece
<input type="checkbox"/> 4.5 wide-angle halogen lamp 500 W (2.0 kg)	68.70 _____ piece
<input type="checkbox"/> 4.6 wide-angle halogen lamp 500 W (2.0 kg) / from 5 pieces	45.60 _____ piece
<input type="checkbox"/> 4.7 wide-angle halogen lamp 500 W (2.0 kg) / from 10 pieces	42.60 _____ piece
<input type="checkbox"/> 4.8 wide-angle halogen lamp 1000 W (2.5 kg)	76.20 _____ piece
<input type="checkbox"/> 4.9 wide-angle halogen lamp 1000 W (2.5 kg) / from 5 pieces	54.40 _____ piece
<input type="checkbox"/> 4.10 wide-angle halogen lamp 1000 W (2.5 kg) / from 10 pieces	51.50 _____ piece
<input type="checkbox"/> 4.11 spotlight up to 200 W (-1.2 kg), single installation, including bulb	68.70 _____ piece
<input type="checkbox"/> 4.12 spotlight up to 200 W (-1.2 kg), in a rail, including bulb	68.70 _____ piece
<input type="checkbox"/> 4.13 spotlight up to 200 W (-1.2 kg), in a rail, including bulb, from 5 pieces	68.70 _____ piece
<input type="checkbox"/> 4.14 spotlight up to 200 W (-1.2 kg), in a rail, including bulb, from 10 pieces	45.60 _____ piece
<input type="checkbox"/> 4.15 spotlight up to 200 W (-1.2 kg) with arm (-500 mm), including bulb	42.60 _____ piece

Other area floodlights / lighting elements are shown overleaf.

**The ordered services have to be paid without delay after receiving the invoices.
Invoices may be issued before the start of the event.**

All prices in EURO plus VAT at the statutory rate.

* If necessary, NürnbergMesse is entitled to have the service ordered provided by another ServicePartner. In this case, the customer will be notified of the other ServicePartner in good time.

With our authorized signature below, we acknowledge acceptance of all items of the General and Special Terms of Business of NürnbergMesse and the General Terms of Business and the Special Conditions for Services of the ServicePartner.

Place and date _____

Company stamp and authorized signature _____

Accessories for suspension + lighting

Order (continued)

5. Profile spotlights					
Dual-lens system for exact definition of projection and dark areas					
		EUR / piece			
<input type="checkbox"/>	5.1 19° 600/750 W (5.9/6.3 kg)	85.80	_____	piece	
<input type="checkbox"/>	5.2 26° 600/750 W (5.9/6.3 kg)	93.00	_____	piece	
<input type="checkbox"/>	5.3 36° 600/750 W (5.9/6.3 kg)	93.00	_____	piece	
6. Follow spotlights					
Powerful daylight follow spot, iris, shutter, dimmer, colored + white					
		EUR / piece			
				on request	
7. Moving lights					
Moving-head spotlight with color and gobo wheel, dimmer, shutter, without gobo					
		EUR / piece			
<input type="checkbox"/>	7.1 MAC 250 Entour (22.4 kg)	321.90	_____	piece	
<input type="checkbox"/>	7.2 MAC 700 (34.5 kg)	436.30	_____	piece	
<input type="checkbox"/>	7.3 MAC 2000 (53.5 kg)	835.20	_____	piece	
8. Light controllers / dimmers					
Controllers for all common spotlights					
		EUR / piece			
<input type="checkbox"/>	8.1 MA Lightcommander 12/2	107.30	_____	piece	
<input type="checkbox"/>	8.2 MA Lightcommander 24/6	157.40	_____	piece	
<input type="checkbox"/>	8.3 MA Lightcommander 48/6	400.50	_____	piece	
<input type="checkbox"/>	8.4 MA Scancommander	257.50	_____	piece	
<input type="checkbox"/>	8.5 Controller for RGB flood	59.70	_____	piece	
<input type="checkbox"/>	8.6 Camco 1210	174.50	_____	piece	
<input type="checkbox"/>	8.7 LLT DiDi 24/2	357.70	_____	piece	
<input type="checkbox"/>	8.8 LLT DiDi 48/2	543.60	_____	piece	
9. Other spotlights					
		EUR / piece			
<input type="checkbox"/>	9.1 RGB flood 2000 W (7.5 kg) (color mixer, mixable via DMX)	95.80	_____	piece	
<input type="checkbox"/>	9.2 High-power LED wash light RGB 63x1 W (5.8 kg)	90.10	_____	piece	
<input type="checkbox"/>	9.3 Domino spotlight 1000 W (4.4 kg) (asymmetrical backdrop flood)	69.40	_____	piece	
<input type="checkbox"/>	9.4 Architectural spotlight for illuminating large areas CC1800 W (56 kg)	357.70	_____	piece	
<input type="checkbox"/>	9.5 Architectural spotlight for illuminating large areas CC2500 W (58 kg)	543.60	_____	piece	

All prices in EURO plus VAT at the statutory rate.

Orders must be received by the organizer in a complete and correct form within the return deadline set for the respective event. SAG GmbH is under no obligation to provide services for orders or changes to existing orders that do not meet these requirements.
Orders for mains power connections, suspensions, truss and compressed air connections – in so far as SAG GmbH can still process such orders or changes to existing orders – will be subject – from 3 weeks prior to the event – to a surcharge by SAG GmbH of 25 %. Other articles/services will be subject – from 14 days prior to the event – to a surcharge of 25 % for services according to a fixed price and/or 50 % for services according to time expenditure.

Other lighting systems on request!

Further information and the **Special Conditions for Services** of SAG GmbH for lighting can be found on our Internet site at www.sag-servicepartner.de.

Plan of lighting

Plan of stand showing exact position

Important! This plan is not for stand construction purposes!

Adjacent stand no.:	Adjacent stand no.: _____														

With our authorized signature below, we acknowledge acceptance of all items of the General and Special Terms of Business of NürnbergMesse and the General Terms of Business and the Special Conditions for Services of the ServicePartner.

Place and date _____

Company stamp and authorized signature _____

Nuremberg, Germany
14–16.3.2017



embeddedworld2017
Exhibition&Conference
... it's a smarter world

Return to
NürnbergMesse GmbH
MesseService
Messezentrum
90471 Nürnberg
Tel +49 (0) 9 11. 86 06-80 00
Fax +49 (0) 9 11. 86 06-80 01
messeservice@nuernbergmesse.de

Contractor *
SAG GmbH
ServicePartnerCenter
Messezentrum
90471 Nürnberg
Tel +49 (0) 9 11. 81 88 18-0
Fax +49 (0) 9 11. 81 88 18-19
sag-messe@sag.eu

Company _____

Street _____
Postcode, Town, Country _____
Tel _____
Fax _____
E-mail _____

Return deadline **Hall/Stand**
10.1.2017

Person to contact _____
Tel _____
Fax _____
Invoice address (only if different) _____

Order

VAT ID number of exhibitor:

□□ □□□□□□□□□□□□□□□□

1. Main connection (maximum 7.5 bar) EUR

Compressed air line to the connection of the stand area including fitting stop valve and delivery costs

- 1.1 Nominal size up to 1/2" with quick coupling (max. 700 l/min.) (Art. 2010010) 417.00
- 1.2 Nominal size up to 1" with ball valve (max. 1,500 l/min.) (Art. 2010020) 619.50

The required air flow is: _____ l/min.
Please draw the required connection points into the stand plan.

The stand will be connected from main connection by our own staff or our stand builder: yes no

We use a raised floor: yes no

Clearance height of raised floor: _____ mm

2. Work at hourly rate EUR

- 2.1 Fitter including all surcharges @/h. 42.90
- 2.2 Master craftsman / technician including all surcharges @/h. 64.80

The following stand installations have to be carried out by the ServicePartner SAG GmbH:

The compressed air is available during the official assembly and dismantling. During the event the compressed air is available from 8:00 till end of the event. For safety reasons, the compressed air supply is switched off during all other times.

We require compressed air supply besides the above times (extra charges):

Date: from _____ till _____

Time: from _____ till _____

3. Stand installation/material for rental EUR

assembly/dismantling and rental fees from main connection

- 3.1 additional connection up to 1/2" (Art. 2050010) piece @ 71.40
- 3.2 adapter 1" to 1/2" (Art. 2050020) piece @ 24.30
- 3.3 pipe manifold double 1" to 1/2" (Art. 2050030) piece @ 29.70
- 3.4 pipe manifold triple 1" to 1/2" (Art. 2050040) piece @ 35.10
- 3.5 pipe manifold quadruple/six-fold 1" to 1/2" (Art. 2050050) piece @ 43.95
- 3.6 double junction up to 1/2" (Art. 2050060) piece @ 20.90
- 3.7 triple junction up to 1/2" (Art. 2050070) piece @ 27.60
- 3.8 quick coupling up to 1/2" (Art. 2050080) piece @ 11.00
- 3.9 pressure reducer adjustable variability (Art. 2050090) piece @ 36.30
- 3.10 installation of 1/2" compressed air hose at the stand (Art. 2050100) m@ 4.20
- 3.11 installation of 1" compressed air hose at the stand (Art. 2050110) m@ 7.00

4. Industrial gas and vacuum on request

All prices in EURO plus VAT at the statutory rate.

Orders must be received by the organizer in a complete and correct form within the deadline set for the respective event. SAG GmbH is under no obligation to provide services for orders that do not meet these requirements.

Orders for mains power connections, suspensions, truss and compressed air connections – in so far as SAG GmbH can still process such orders or changes to existing orders – will be subject – from 9 weeks prior to the event – to a surcharge by SAG GmbH of 25 %. Other articles/services will be subject – from 14 days prior to the event – to a surcharge of 25 % for services according to a fixed price and/or 50 % for services according to time expenditure.

The services ordered must be paid without delay after receipt of the invoice. The invoice may be issued before start of the event.

Note on safety:

Compressed air can be dangerous. It is essential to observe the safety precautions to avoid serious accidents.

Further information and the Special Conditions for Services of SAG GmbH for compressed air supply can be found on our Internet site at www.sag-servicepartner.de.

* If necessary, NürnbergMesse is entitled to have the service ordered provided by another ServicePartner. In this case, the customer will be notified of the other ServicePartner in good time.
With our authorized signature below, we acknowledge acceptance of all items of the General and Special Terms of Business of NürnbergMesse and the General Terms of Business and the Special Conditions for Services of the ServicePartner.

Place and date _____

Company stamp and authorized signature _____

Nuremberg, Germany
14–16.3.2017



embeddedworld2017

Exhibition & Conference
... it's a smarter world

Return to
NürnbergMesse GmbH
MesseService
Messezentrum
90471 Nürnberg
Tel +49 (0) 9 11. 86 06-80 00
Fax +49 (0) 9 11. 86 06-80 01
messe-service@nuernbergmesse.de

Contractor *
Halls 3–7
August & Jean HILPERT
Messe-Service GmbH
Halls 1–2, 8–12
Brochier
Gebäudemanagement GmbH

Company _____

Street _____

Postcode, Town, Country _____

Tel _____

Fax _____

E-mail _____

Return deadline
14.12.2016

Hall/Stand

Person to contact _____

Tel _____

Fax _____

Invoice address (only if different) _____

VAT ID number of exhibitor:

Order (Special Conditions for Services overleaf)

The order includes the following (Note: Materials are rental goods):

- Installation and dismantling of water and wastewater pipes and connection of one terminal appliance
- Water supply connection including tap and shutoff valve 1/2" or 3/4"
- A wastewater connection with 50 mm diameter (note: 65 mm diameter in the connecting sleeve area – i.e. height clearance of at least 65 mm is required for overbuilding with a raised floor.)

Note: A water connection is basically only possible if there is a water connection depicted inside the stand area in the hall plan. All hose and pipe connections are laid on the hall floor from the main connection (see hall plan)!

- A water supply pipe/wastewater pipe with a length of up to max. 10 m from the duct outlet. Longer distances will be charged according to item 4.10.

Regularly flushed inlet

1. All-inclusive package 1

- 1.1 Installation with equipment not supplied by us (provided by exhibitor) (Art. 50050001) EUR 371.60**
 - Stand installation of water and drainage
 - Connection of one item of equipment (e.g. sink incl. water heater ...), (equipment supplied by exhibitor/ not rented from HILPERT or Brochier)
 - plus water and drainage fee **EUR 29.90**
- 1.2 Installation with equipment supplied by HILPERT or Brochier (Art. 50050002) EUR 344.60**
 - See 1.1 but equipment must be rented from HILPERT or Brochier (see Item 4 ff.)
 - plus water and drainage fee **EUR 29.90**

- 2. Extra equipment connection only as addition to package 1.1 (Art. 50050003) EUR 52.50**

Connection fee for each additional item of equipment (equipment supplied by exhibitor/not rented from HILPERT or Brochier)

- | | |
|--|--|
| <input type="checkbox"/> Single sink | <input type="checkbox"/> Counter |
| <input type="checkbox"/> Dishwasher | <input type="checkbox"/> Coffee percolator |
| <input type="checkbox"/> Filter/safety device | <input type="checkbox"/> Steamer/terminal unit |
| <input type="checkbox"/> Other equipment _____ | |

Total items of equipment to be connected _____

- 3. Separate tap, e.g. for filling pools (Art. 50050004) EUR 123.10**
 - plus water and drainage fee **EUR 29.90**

* If necessary, NürnbergMesse is entitled to have the service ordered provided by another ServicePartner. In this case, the customer will be notified of the other ServicePartner in good time.

With our authorized signature below, we acknowledge acceptance of all items of the General and Special Terms of Business of NürnbergMesse and the General Terms of Business and the Special Conditions for Services of the ServicePartner.

Place and date _____

4. Rental equipment from ServicePartner (HILPERT/Brochier)

Rental fee including installation only as addition to package 1.2 (except item 4.5) (see back of Form S2.31 for illustration)

- 4.1 Single sink/stainless steel with base unit, 50 x 53 cm (Art. 50030070) EUR 96.00**
- 4.2 Single sink with stainless steel drainer and base unit, 80 x 53 cm (Art. 50030075) EUR 120.50**
- 4.3 Double sink, stainless steel with base unit, 80 x 53 cm (Art. 50030080) EUR 120.50**
- 4.4 Single sink/stainless steel with base unit, 80 x 53 cm drainer, with water heater mounted below (Art. 50030085) EUR 214.00**
- 4.5 Single sink with stainless steel drainer and base unit, 80 x 53 cm, (pump-operated, for stand spaces without water supply only) (Art. 50030090) EUR 236.10**
 - plus water and drainage fee **EUR 29.90**
- 4.6 Kitchen unit, 90 x 60 cm (with 2 hotplates, refrigerator, water heater) (Art. 50030100) EUR 301.00**
- 4.7 Thermofix water heater (Art. 50030105) EUR 111.00**
- 4.8 Catering glass dishwasher (for cups or glasses, program time approximately 3-5 min.) (Art. 50030110) EUR 313.00**
- 4.9 Catering dishwasher (for crockery, program time approximately 3-5 min.) (Art. 50030115) EUR 479.00**
- 4.10 For installations with exhibitor's own appliance or an appliance of the ServicePartner, a pipe length (water supply and wastewater pipe) of 10 m is included. Per each additional meter **EUR 40.10****

- 5. Fitter's flat rate per hour EUR 46.00**

The flat rate includes surcharges such as overtime hours, Sundays and public holidays. Further work will be charged according to time and material used.

The connection of a water supply is only possible if a water outlet is located within the stand (as shown on hall plan). Installations from the supply point to the equipment connection point must be laid across the hall floor.

Please submit a plan of the stand on Form S2.31, showing the accurate locations of the desired facilities.

Shut-off valves (ball valves) must be turned off every evening.

We use a raised floor: yes no
Height clearance of floor structure: _____ cm **Note: Height clearance of at least 65 mm is required for complete overbuilding of the supply and discharge pipes.**

To be fitted in the stand by the ServicePartner:

Company stamp and authorized signature _____

Special Service Terms & Conditions of NürnbergMesse GmbH for water and wastewater connection

1. Integral parts of the Agreement

Integral parts of the Agreement in the following sequence and ranking are:

- the respective order forms and online forms
- these Service Terms & Conditions for water and wastewater
- the Special Conditions for Participation in the relevant event
- the General Conditions for Participation in Fairs and Exhibitions
- the General Contractual Terms & Conditions for the Service Manual (AVB)

In case of any conflict between these terms and conditions, the terms and conditions shall take a priority ranking position in accordance with the aforementioned order of precedence.

2. Order, Execution of the Agreement

Services may be ordered only after receipt of stand space confirmation. The order must be accepted by NürnbergMesse. After the order, the Agreement is formed once the exhibitor receives an invoice with order confirmation from NürnbergMesse or one of the ServicePartners stipulated under Item 4. The automatically generated confirmation of receipt sent by e-mail directly after the online order has been placed does not represent an order confirmation. Acceptance of the order can also be made implicitly by providing the ordered services. A water and wastewater connection can only be provided if such a connection is already available at the rented stand space. The connections are indicated in the hall blueprint plan (integral part of the stand space confirmation). Even if an exhibitor has received the invoice/order confirmation from NürnbergMesse, they will receive a separate invoice/order confirmation directly from the ServicePartner in respect of special services ordered that are not included in the standard range in the (online) order form.

3. Stand layout sketch, Connections for equipment/appliances, Requirements regarding stand construction

The stand layout sketch that indicates the required connections shall be submitted by the exhibitor with the order or no later than two weeks prior to the start of the event. The exhibitor already received the hall blueprint plan, which indicates the site of the water and wastewater connection, with the stand confirmation. Connections for equipment/appliances can be situated directly adjacent to the water and wastewater connection. The ServicePartners shall endeavor to also install connections requested by the exhibitor that deviate from existing connections. The exhibitor has no claim to installation of connections at the requested site, as this depends on the stand construction. If the exhibitor wishes to have a variant connection, e.g., away from the existing water and wastewater connection, it is up to the exhibitor to plan and execute the stand construction in such a way that the water and wastewater pipes can be laid safely and are covered and protected. In the event of questions in this regard, the exhibitor is requested to contact the appropriate ServicePartner.

4. Execution by the ServicePartner

The contractual services are generally executed by one of the following Service Partners. The exhibitor's contractual partner remains NürnbergMesse. Within the scope of the transaction of the order, the ServicePartners have the right to represent NürnbergMesse.

ServicePartners:

Halls 3-7A

August & Jean HILPERT
Messe-Service GmbH
Messezentrum, 90471 Nürnberg
ServicePartnerCenter
(2. OG, Zimmer 2.40)
Tel +49 (0) 9 11. 37 66 38-0
Tel +49 (0) 1 71. 3 30 11 46 (emergency call)
Fax +49 (0) 9 11. 37 66 38-29
service@hilpert-messe.de
www.hilpert-messe.de

Halls 1, 2, 8-12
Brochier
Messezentrum Nürnberg
ServicePartnerCenter
Tel +49 (0) 9 11. 9 81 29 78
Tel +49 (0) 1 51. 12 24 24 80 (emergency call)
Fax +49 (0) 9 11. 9 81 29 79
sp-messe-nbg@a-brochier.de
www.a-brochier.de
Brochier
Gebäudemanagement GmbH
Schülerstraße 8, 90482 Nürnberg
Tel +49 (0) 9 11. 54 42-3 33
Fax +49 (0) 9 11. 54 42-2 45

5. Express surcharge, Exclusion of warranty for orders on short notice, Additional costs for modifications

For orders on short notice or for which a sketch was submitted too late (less than two weeks' notice prior to the start of the official set-up), the following express surcharge will be applied to the amount of the order:

for services at fixed prices	25 %
for cost-plus work	50 %

In the event an order is received with less than two weeks' notice prior to the official beginning of set-up, NürnbergMesse – should it accept the order – assumes no guarantee that the service(s) can be performed properly and in a timely manner. If in such cases NürnbergMesse does not perform the services, does not complete them on time, or supplies defective services, the exhibitor can rescind the Agreement relative to water/wastewater or reduce the agreed upon compensation only if the statutory prerequisites have been met. Additional claims for compensation for damages or for reimbursement of expenditures are excluded, unless the short notice of the order was not concurrently causative for non-performance or defective performance by NürnbergMesse. Liability for intentional or grossly negligent breaches of duty by NürnbergMesse or its vicarious agents and liability due to culpable harm to life, limb, or health shall remain unaffected.

Should the exhibitor request that services already performed by NürnbergMesse or the performance of which has already commenced be subsequently modified, NürnbergMesse has the right – should it agree to perform these modifications – to charge the exhibitor for the actual additional work and expense that accrue for each modification.

6. Compensation/Fees

None of the quoted prices contain the legally mandated, current value-added tax. The agreed compensation shall become due as soon as the order is accepted by NürnbergMesse.

Calculation of the quoted prices has been pegged to wages based on a 40-hour work week. For services at fixed prices that have not yet been defined at the time stipulated for the start of set-up or that cannot be commenced at this time due to incomplete or unusable order information or instructions, a surcharge of 25 % and for cost-plus work a surcharge of 50 % can be added to the prices listed overleaf. A processing fee of EUR 50 plus the legally mandated, current value-added tax shall be charged for invoices that must be reissued due to erroneous or inaccurate information provided by the applicant (exhibitor). This fee shall be shown on the reissued invoice.

7. Prohibition of work by exhibitor, Penalty

For safety reasons, the shaft connection and the connection of terminal equipment (e.g., sink, dishwasher, etc.) may be executed solely by ServicePartners of NürnbergMesse. It is prohibited to independently open connections, open supply shafts and extract water, tap existing pipes, connect neighboring stands belonging to other exhibitors, and independently connect terminal equipment or appliances. In the event of culpable breaches by the exhibitor against the aforementioned regulation, a penalty of EUR 500 per violation shall be assessed. We reserve the right to claim additional damages.

8. Security regulations to be complied with by the exhibitor

Cut-off valves (ball valves) must be shut off prior to leaving the stand. Costs for any damages that occur due to cut-off/ball valves not having been shut off shall be borne by the exhibitor. Use of rubber hoses of any kind during installation are not permitted under any circumstances.

9. Cancellation

Item 9 of the General Conditions for Participation in Fairs and Exhibitions shall apply to cancellations by the exhibitor.

10. Delivery of rental equipment/appliances to exhibitors, connection of terminal equipment/appliances/appliances

Rental equipment/appliances can only be delivered and connected during the official set-up phase; the same applies to the connection of terminal equipment/appliances belonging to the exhibitor, which may also only be executed by Service Partners. Therefore, the exhibitor must contact the appropriate ServicePartner no later than 12:00 noon on the last day of set-up and request services. Should the service request not be made in a timely manner, the timely execution of services and/or timely delivery cannot be guaranteed.

11. Acceptance, Delivery, Claims

After completion, the service must be inspected and accepted by the exhibitor. The ServicePartner who performed the service(s) and the exhibitor shall draw up and sign an acceptance and delivery report.

The exhibitor undertakes to inspect the services performed for defects and completeness at the time of acceptance. Visible defects or instances where the order is incomplete shall be recorded in the acceptance and delivery report. Should a defect be discovered at a later date, the exhibitor shall notify the ServicePartner who performed the service(s) promptly after its discovery and request subsequent performance. Warranty claims that impose a time limit for subsequent performance cannot be asserted after the end of the event, unless the right to subsequent performance did not or did no longer exist during the event.

NürnbergMesse does not assume any liability for the consequences of pressure failure or pressure changes or for damages to the site.

12. Return of the rental equipment/appliances and furnishings and fittings

Water inflow and outflow materials, stop valves, faucets, sinks, dishwashers, and other equipment shall be made available to the exhibitor solely in the form of a rental. The exhibitor is responsible for the rental equipment and furnishings and fittings until they have been returned. The rental equipment and furnishings and fittings may only be dismantled by the ServicePartner. Dismantling and pick-up shall be conducted at the end of the last day of the event or by the end of the final day of dismantling. The rental equipment and furnishings and fittings may not be left behind by the exhibitor without being returned to the ServicePartner. Should the exhibitor wish to vacate the stand early, the exhibitor shall contact the appropriate ServicePartner in a timely manner to agree on a return date and time. Wash basins and sinks must be returned in a clean condition. Should wash basins and sinks be returned without having been cleaned, the exhibitor can be charged a cleaning fee of EUR 100.

13. Exhibitor's liability

The exhibitor shall be liable in accordance with the statutory provisions in the event of damage or loss to the rental equipment or other furnishings and fittings. The exhibitor is responsible for any fault on the part of its employees or other vicarious agents.

Illustration of rental equipment

Equipment	Designation
	4.1 Single sink H x W x D 85 x 50 x 53 cm
	4.2 Single sink with drainer H x W x D 85 x 80 x 53 cm
	4.3 Double sink H x W x D 85 x 80 x 53 cm
	4.4 Single sink with drainer and water heater H x W x D 85 x 80 x 53 cm
	4.5 Single sink with drainer (pump-operated) H x W x D 85 x 80 x 53 cm
	4.6 Kitchen unit, with 2 hotplates, refrigerator, water heater H x W x D 90 x 90 x 60 cm
	4.7 Thermofix water heater
	4.8 Catering glass dishwasher for cups or glasses programe time approximately 3-5 min. H x W x D 86 x 50 x 55 cm
	4.9 Catering dishwasher for crockery programe time approximately 3-5 min. 400 V/5.7 kW H x W x D 135 x 60 x 60 cm

Example of plan

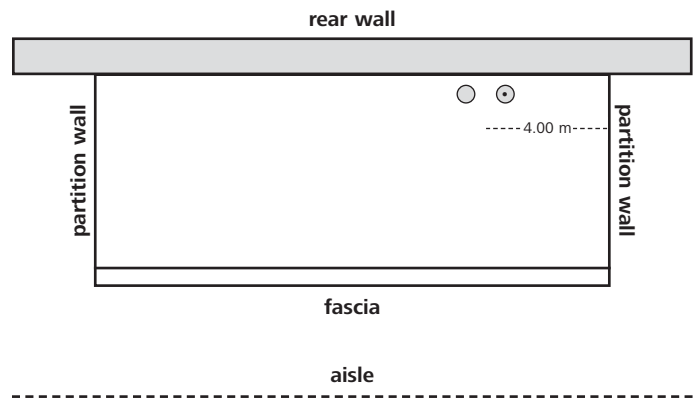

- ⊙ water supply with position of pipes
- drainage with position of pipes
(not binding, as the position of pipes generally depends on the connection possibilities.)
- X** water heater
- sink
- S** dishwasher

Nuremberg, Germany
14–16.3.2017



Return to
NürnbergMesse GmbH
MesseService
Messezentrum
90471 Nürnberg
Tel +49 (0) 9 11. 86 06-80 10
Fax +49 (0) 9 11. 86 06-80 01
communication@nuernbergmesse.de

Contractor *
Unify Deutschland GmbH & Co. KG
Dr.-Mack-Straße 91
90762 Fürth
Tel +49 (0) 9 11. 86 06-48 48

Company _____

Street _____

Postcode, Town, Country _____

Tel _____

Fax _____

E-mail _____

Return deadline	Hall/Stand
14.12.2016	
Person to contact _____	
Tel _____	
Fax _____	
Invoice address (only if different) _____	



VAT ID number of exhibitor:

1. Standard: ADSL

- 1.1 Asynchronous Internet Provision 4 Mbit/s**
- Highspeed ADSL Internet connection: up to 4 Mbit/s downstream and 512 kbit/s upstream
 - Flat rate (no volume and time limit)
 - Including technical installation and a DSL router with 1 Ethernet user port
 - Including one dynamic IP address
- (Art. 51001010) **EUR 295.00** Items _____
- One fixed public IP address optional
(Art. 51000000) **EUR 65.00**
- 1.2 Asynchronous Internet Provision 6 Mbit/s**
- Highspeed ADSL Internet connection: up to 6 Mbit/s downstream and 1 Mbit/s upstream
 - Flat rate (no volume and time limit)
 - Including technical installation and a DSL router with 1 Ethernet user port
 - Including one dynamic IP address
- (Art. 51001021) **EUR 460.00** Items _____
- One fixed public IP address optional
(Art. 51000000) **EUR 65.00**
- 1.3 Asynchronous Internet Provision 16 Mbit/s**
- Highspeed ADSL Internet connection: up to 16 Mbit/s downstream and 1 Mbit/s upstream
 - Flat rate (no volume and time limit)
 - Including technical installation and a DSL router with 1 Ethernet user port
 - Including one dynamic IP address
- (Art. 51001030) **EUR 850.00** Items _____
- One fixed public IP address optional
(Art. 51000000) **EUR 65.00**

2. Professional: SDSL/VDSL

- 2.1 Synchronous Internet Provision 4 Mbit/s**
- Highspeed SDSL Internet connection: up to 4 Mbit/s downstream and 4 Mbit/s upstream
 - Flat rate (no volume and time limit)
 - Including technical installation and a SDSL router with 1 Ethernet user port
 - Including one fixed public IP address
- (Art. 51002010) **EUR 1,050.00** Items _____
- Additional fixed public IP address on request
- 2.2 Synchronous Internet Provision 10 Mbit/s**
- Highspeed SDSL Internet connection: up to 10 Mbit/s downstream and 10 Mbit/s upstream
 - Flat rate (no volume and time limit)
 - Including technical installation and a SDSL router with 1 Ethernet user port
 - Including one fixed public IP address
- (Art. 51002020) **EUR 1,950.00** Items _____
- Additional fixed public IP address on request
- 2.3 IP Connect Ethernet Internet Provision 50/100 Mbit/s**
- Synchronous highspeed VDSL Internet connection with at least 50 Mbit/s usable
 - Flat rate (no volume and time limit)
 - Including technical installation and a VDSL router with 1 Ethernet user port
 - Including one fixed public IP address
- (Art. 51002030) **EUR 3,250.00** Items _____
- Additional fixed public IP address on request
- 2.4 Other broadband connections (up to 1 Gbits/s)**
- Please send us your enquiry, we will be pleased to prepare an individual offer for you.

For technical reasons the routers provided must be used. Each xDSL connection is provided by Cat. 3 connecting cable or LAN cable from the available supply shaft. The maximum cable length in this case is 5 meters. As final connecting cable we provide a LAN cable with a minimum length of 2 meters.
 * If necessary, NürnbergMesse is entitled to have the service ordered provided by another ServicePartner. In this case, the customer will be notified of the other ServicePartner in good time.
 With our authorized signature below, we acknowledge acceptance of all items of the General and Special Terms of Business of NürnbergMesse and the General Terms of Business and the Special Conditions for Services of the ServicePartner.

Place and date

Company stamp and authorized signature

Nuremberg, Germany
14–16.3.2017



embeddedworld2017

Exhibition&Conference
 ... it's a smarter world

Return to
 NürnbergMesse GmbH
 MesseService
 Messezentrum
 90471 Nürnberg
 Tel +49 (0) 9 11. 86 06-80 10
Fax +49 (0) 9 11. 86 06-80 01
 communication@nuernbergmesse.de

Contractor *
 Unify Deutschland GmbH & Co. KG
 Dr.-Mack-Straße 91
 90762 Fürth
 Tel +49 (0) 9 11. 86 06-48 48

Company _____

Street _____

Postcode, Town, Country _____

Tel _____

Fax _____

E-mail _____

Return deadline	Hall/Stand
14.12.2016	
Person to contact _____	
Tel _____	
Fax _____	
Invoice address (only if different) _____	



VAT ID number of exhibitor:

□□ □□□□□□□□□□□□□□

3. Phone Connections without end device

- 3.1 Analog phone connection**
 - For installation of individual phone, fax or exhibitor's multifunctional devices
 - Without end devices
 - Including technical installation and dial number

(Art. 51003010) **EUR 135.00** Items _____

- 3.2 ISDN Connection**
 - ISDN S0-Connector with DSS1 protocol for installation of small telephone systems, Cash-Terminals, ISDN fax devices
 - Without end devices
 - Including technical installation and two dial numbers

(Art. 51003020) **EUR 155.00** Items _____

Fee Package (mandatory)

- Fee Package**
 - If you order one of the following products 3.1 and 3.2 it is mandatory that you also order the fee package for each single item
 - Communication within every fixed and mobile network
 - To industrialized European countries and large parts of the world *)
 - Maximum of 120 minutes per fair day **)
 - Valid over the entire fair duration

Fair period	1-3 days	EUR 35.00
(Art. 51000010)		
Fair period	4 days and longer	EUR 49.00
(Art. 51000011)		
- *) All European countries as well as China, USA, Canada, Russia, Argentina, Australia, Brazil, Hong Kong, Japan, Korea, Malaysia, New Zealand, Singapore, Taiwan, Thailand
- ***) In case of exceeding 120 minutes on one fair day or telephoning to other countries than the ones named above, we'll charge this on a time and material basis and according to tariff but at least to the amount of EUR 10.
- Special Hotlines (e.g. 0800..., 0190...) are excluded.

* If necessary, NürnbergMesse is entitled to have the service ordered provided by another ServicePartner. In this case, the customer will be notified of the other ServicePartner in good time.
 With our authorized signature below, we acknowledge acceptance of all items of the General and Special Terms of Business of NürnbergMesse and the General Terms of Business and the Special Conditions for Services of the ServicePartner.

Place and date

Company stamp and authorized signature

Nuremberg, Germany
14–16.3.2017



Return to
NürnbergMesse GmbH
MesseService
Messezentrum
90471 Nürnberg
Tel +49 (0) 9 11. 86 06-80 10
Fax +49 (0) 9 11. 86 06-80 01
communication@nuernbergmesse.de

Contractor *
Unify Deutschland GmbH & Co. KG
Dr.-Mack-Straße 91
90762 Fürth
Tel +49 (0) 9 11. 86 06-48 88

Company
Street
Postcode, Town, Country
Tel
Fax
E-mail

Return deadline 14.12.2016
Hall/Stand
Person to contact
Tel
Fax
Invoice address (only if different)



4. Phone Connections with end device

4.1 IP Phone OpenStage 20
• Voice over IP solution
• End device including double-spaced, pivoted display
• Including connector and dial number
(Art. 51004010) EUR 115.00 Items



*) For stand-internal cabling the minimum requirement is CAT5 cable.

4.2 Conference Phone
• Remarkable voice quality
• Ten feet (3.5-meters) of 360-degree microphone pickup range
• Resistance to interference from mobile phones
• Easy to use
• Including technical installation and dial number
(Art. 51006120) incl. one microphone EUR 259.00 Items
(Art. 51006130) incl. one microphone EUR 320.00 Items



4.3 Wireless Phone System Gigaset
• Mobile telephoning within a locally limited DECT area
• Including one wireless Gigaset S685 phone device
• A maximum of 5 additional end devices (Gigaset S680) can be installed
• 30 minutes answering machine
• Including technical installation and dial number
(Art. 51004030) EUR 190.00 Items



4.4 Additional wireless Gigaset devices for Pos. 4.3
• Gigaset S680 telephone system Gigaset
(Art. 51004040) EUR 75.00 Items



4.5 Multifunction unit with fax
• Provides high quality printing, copying, scanning and fax functionality
• Laser printer (black/white)
• Easy handling
• Including technical connection and dial number (excluding driver installation)
• Including max. one replacement of the toner cartridge
(Art. 51004050) EUR 255.00 Items



Fee Package (mandatory)

Fee Package
• If you order one of the following products 4.1-4.3 and 4.5 it is mandatory that you also order the fee package for each single item
• Communication within every fixed and mobile network
• To industrialized European countries and large parts of the world *)
• Maximum of 120 minutes per fair day **)
• Valid over the entire fair duration

Table with 3 columns: Fair period, days, EUR price. Rows: 1-3 days EUR 35.00, 4 days and longer EUR 49.00

*) All European countries as well as China, USA, Canada, Russia, Argentina, Australia, Brazil, Hong Kong, Japan, Korea, Malaysia, New Zealand, Singapore, Taiwan, Thailand
**) • In case of exceeding 120 minutes on one fair day or telephoning to other countries than the ones named above, we'll charge this on a time and material basis and according to tariff but at least to the amount of EUR 10.
• Special Hotlines (e.g. 0800..., 0190...) are excluded.

* If necessary, NürnbergMesse is entitled to have the service ordered provided by another ServicePartner. In this case, the customer will be notified of the other ServicePartner in good time.
With our authorized signature below, we acknowledge acceptance of all items of the General and Special Terms of Business of NürnbergMesse and the General Terms of Business and the Special Conditions for Services of the ServicePartner.

Place and date

Company stamp and authorized signature

Nuremberg, Germany
14–16.3.2017



embeddedworld2017

Exhibition&Conference
... it's a smarter world

Return to
NürnbergMesse GmbH
MesseService
Messezentrum
90471 Nürnberg
Tel +49 (0) 9 11. 86 06-80 10
Fax +49 (0) 9 11. 86 06-80 01
communication@nuernbergmesse.de

Contractor *
Unify Deutschland GmbH & Co. KG
Dr.-Mack-Straße 91
90762 Fürth
Tel +49 (0) 9 11. 86 06-48 48

Company _____

Street _____

Postcode, Town, Country _____

Tel _____

Fax _____

E-mail _____

Return deadline	Hall/Stand
14.12.2016	
Person to contact _____	
Tel _____	
Fax _____	
Invoice address (only if different) _____	



VAT ID number of exhibitor:

5. PC-Equipment

5.1 Workstation

- Notebook with standard office applications and standard web browser
- Flat screen, keyboard and mouse
- Including technical installation



(Art. 51005010) **EUR 310.00** Items _____

5.2 Multifunction unit as printer

- Provides high quality printing, copying, and scanning functionality
- Laser printer (black/white)
- Easy handling
- Including technical connection (no dial number, excluding driver installation)
- Including max. one replacement of the toner cartridge



(Art. 51005020) **EUR 130.00** Items _____

5.3 LAN-Switch

- Switch with 8 ports, Speed: 10/100 Mbit/s
- Ports: 8 x RJ45
- Meets the common standards IEEE 802.3 and IEEE 802.3u.

(Art. 51005030) **EUR 110.00** Items _____

6. Special Services

6.1 Cable Supply to the fair stand

- Copper cable supply from the main distribution frame to the fair stand

(Art. 51006010) **EUR 255.00** Items _____

6.2 Optical Fiber Connection

- Optical Fiber Connection between exhibitor's stands

(Art. 51006020) **Price on application** Items _____

6.3 Manpower per 15 minutes

- Field working and additional activities by separate technician
- Charging according to actual effort

(Art. 51006030) **EUR 35.00**

* If necessary, NürnbergMesse is entitled to have the service ordered provided by another ServicePartner. In this case, the customer will be notified of the other ServicePartner in good time.
With our authorized signature below, we acknowledge acceptance of all items of the General and Special Terms of Business of NürnbergMesse and the General Terms of Business and the Special Conditions for Services of the ServicePartner.

Place and date

Company stamp and authorized signature

Nuremberg, Germany
14-16.3.2017



embeddedworld2017
 Exhibition&Conference
 ... it's a smarter world

Return to
 NürnbergMesse GmbH
 MesseService
 Messezentrum
 90471 Nürnberg
 Tel +49 (0) 9 11. 86 06-80 10
Fax +49 (0) 9 11. 86 06-80 01
 communication@nuernbergmesse.de

Contractor *
 Unify Deutschland GmbH & Co. KG
 Dr.-Mack-Straße 91
 90762 Fürth
 Tel +49 (0) 9 11. 86 06-40 00/-48 48

Return deadline
14.12.2016

Hall/Stand

Company _____

Street _____

Postcode, Town, Country _____

Tel _____

Fax _____

E-mail _____

Person to contact _____

Tel _____

Fax _____

Invoice address (only if different) _____

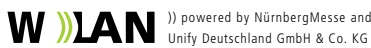

Note: To achieve optimum performance we recommend configuring your WLAN hardware to 5 GHz or the a band (802.11a).

1.1 Single User Access

- Single user access during the whole fair period
- Internet connection with speed up to 10 Mbit/s (symmetric)
- Comprehensive availability throughout the complete fair area
- Flat rate (no volume and time limit)

(Art. 52001010) **EUR 285.00** Items _____

1.2 Multi User Access

- The beneficial bonus package for mobile work:
Single user access for 2 – 5 computers
- Internet connection with speed up to 10 Mbit/s (symmetric)
- Comprehensive availability throughout the complete fair area
- Flat rate (no volume and time limit)

(Art. 52001020) **EUR 550.00** Items _____

Additional access

(Art. 52001021) **EUR 85.00** Items _____

VAT ID number of exhibitor:

□ □



* If necessary, NürnbergMesse is entitled to have the service ordered provided by another ServicePartner. In this case, the customer will be notified of the other ServicePartner in good time. With our authorized signature below, we acknowledge acceptance of all items of the General and Special Terms of Business of NürnbergMesse and the General Terms of Business and the Special Conditions for Services of the ServicePartner.

Place and date

Company stamp and authorized signature

Terms of Business for Communications

1. Parts of contract

The contract comprises the following parts in the order of precedence shown:

- the respective order forms;
- these Terms of Business for Communications;
- the General and Special Conditions for Participation in Fairs and Exhibitions;
- the General Terms of Contract for the Exhibitors Info Manual;
- the terms of business and specifications for services provided by external network operators (e.g. Unify Deutschland GmbH & Co. KG).

2. Orders

The information and communications services listed overleaf can only be ordered from NürnbergMesse. Orders are subject to acceptance by NürnbergMesse, which may be given implicitly, i.e. by providing the ordered service.

An express surcharge of 25 % of the value of the order will be charged for orders placed at short notice (< 14 days before start of event). This does not apply to orders for WLAN.

If the exhibitor requires changes to services already provided by NürnbergMesse, particularly for the exhibition stand, and NürnbergMesse undertakes to carry out the changes, NürnbergMesse may impose a charge to cover the extra cost actually incurred for work connected with each change.

If the order is received and accepted by NürnbergMesse less than five weeks before the start of the event, NürnbergMesse cannot accept responsibility for the correct and timely provision of the service.

If in such cases NürnbergMesse fails to provide its services or does not provide them correctly or in time, the exhibitor shall only be entitled to withdraw from the contract for the information and communication services listed overleaf or to appropriately reduce the agreed payment. Any further claims are excluded.

Complete or partial cancellation of the order is possible in accordance with Item 9 of the General Conditions for Participation in Fairs and Exhibitions.

3. Provision period

The information and communications services ordered will be provided for the duration of the relevant event. If exhibitors require information and communications services to be provided outside this period, these additional services must be requested separately from NürnbergMesse.

4. Provision

All services ordered will be provided by NürnbergMesse or its appointed subcontractors. Equipment will be rented to the exhibitor. The exhibitor shall treat the equipment provided with care and only use it for the purposes specified in the contract. Where the exhibitor's own terminal equipment is used, it must conform to the applicable legal provisions, including current EU Directives on terminal equipment and the CCITT recommendations, particularly recommendation I430. If the exhibitor does not adhere to the technical standards and faults arise as a result, NürnbergMesse may demand reimbursement by the exhibitor of the costs of fault analysis and clearance. NürnbergMesse may also demand that the exhibitor removes the terminal equipment causing the faults from the network immediately. For Internet accesses, the network cards used in the exhibitor's PCs must conform to the Ethernet specifications (IEEE 802.3). The requested optional fixed IP addresses and access data will be supplied to the exhibitor with the invoice and activated on settlement of the invoice. The exhibitor must not use any IP addresses other than those provided by NürnbergMesse or change the specified subnet masks. If the exhibitor does not comply with this obligation and faults arise as a result, NürnbergMesse is entitled to demand reimbursement by the exhibitor of the costs of fault analysis and clearance. NürnbergMesse expressly reserves the right to enforce further damage claims. NürnbergMesse may also exclude from the LAN any exhibitors who, despite prior warning, use IP addresses other than those allocated to them or use other subnet masks than those specified and demand compensation for the associated costs.

If faults occur in the PC of an exhibitor, who is using other IP addresses than those allocated or who has changed the subnet masks, NürnbergMesse will, at the request and risk of the exhibitor, attempt to rectify the fault subject to the NürnbergMesse charges applicable for the period of the event. No guarantee of fault rectification can be given.

At the request of the exhibitor, the ServicePartner of NürnbergMesse will configure the PC, where this is technically and operationally feasible, at the exhibitor's own risk and at the prices applicable at the time of the event.

5. Service points/user help desk

A user help desk has been set up to deal with faults. The service points can be reached on the following numbers:

- Communication products (xDSL, phones, ...): +49 (0) 9 11. 86 06-48 48
- Wireless LAN products: +49 (0) 9 11. 86 06-40 00/-48 48

The user help desk can be reached as follows:

3 days before and during the event:

Mon – Sun and holidays, 8:00 to 19:00 or until end of event

Outside event hours and during the dismantling period:

Mon – Fri, 9:00 to 17:00

6. Loss/liability

If technical terminal equipment is lost or damaged by the fixed stand dismantling deadline (see Item 10, return), NürnbergMesse reserves the right to claim damages from the exhibitor according to the value category and to issue an according invoice.

Our value categories for loss and damage are:

- Category A → EUR 300.00 (e.g. ADSL modem, telephones, printers, fax units and other communication terminal equipment)
- Category B → EUR 1,000.00 (e.g. SDSL and VDSL modem, Wireless LAN router)
- Category C → EUR 1,500.00 (e.g. PC, Tablet-PC and other computer products)

The exhibitor retains the right to prove that no damage or considerably less damage than the fixed value has been caused.

The exhibitor will be liable for any loss, damage or destruction of all communications equipment provided to him. Where liability is dependent on blame, it is the responsibility of the exhibitor to demonstrate that he is not to blame.

7. Liability of organizer

The liability of the organizer is governed by Item 19 of the General Conditions for Participation in Fairs and Exhibitions.

8. Terms and conditions for lines

All lines and equipment will be provided exclusively by NürnbergMesse or its ServicePartner. The fee is payable for the provision of the information and communication service, irrespective of whether it is actually used by the exhibitor. NürnbergMesse ensures that the information and communication access is provided and that any faults and failures during the service times are cleared quickly. Faults and failures are to be reported to NürnbergMesse without undue delay, otherwise rapid processing of the fault and restoration of the information and communication access cannot be assured.

The exhibitor is obliged to keep the user IDs and passwords assigned to him secret and to ensure that these cannot be accessed by third parties. Unless otherwise expressly agreed, the disclosure of user IDs and passwords to third parties to enable them to use the information and communication services is prohibited. The exhibitor is obliged to use the information and communication access only in the correct manner using the login facilities provided (user ID, password etc.) and not to bypass any access restrictions. Any hardware and technical equipment provided by the exhibitor himself must be prepared in accordance with current state-of-the-art technology in order to guarantee operation when used with the NürnbergMesse TC lines. No guarantee can be given for perfect and/or full functionality of the hardware provided by the exhibitor. The exhibitor himself is solely responsible for the security and functionality of data traffic involving his own hardware and technical equipment.

The exhibitor is aware that unencrypted data exchange over wireless media may be intercepted by third parties.

The use of the Internet is at the exhibitor's own risk.

Unless otherwise indicated, all contents constitute third-party content for the purposes of § 8 German Telemedia Act (TMG) and the exhibitor himself is responsible for accessing this information. This particularly applies to possible damage to his hardware or software, data loss or other adverse effects attributable to the use of the Internet over the information and communication infrastructure, provided the incident causing such damage has not been caused by NürnbergMesse in accordance with Item 19 of the General Conditions for Participation in Fairs and Exhibitions.

The exhibitor is responsible for the correct use of the information and communication connections using the user ID assigned to him. The exhibitor ensures that no prohibited or illegal contents are accessed or published and that no other actions contravening applicable regulations or third party rights are taken or tolerated. In the event of NürnbergMesse incurring costs or damages due to inquiries by investigating bodies and authorities, requests for information or other official or private measures or claims in connection with the rented access/IP address, the exhibitor shall be obliged to compensate for the damage already incurred and any that follows, unless he proves that he is not responsible for the use of the information and communication access by third parties.

NürnbergMesse reserves the right to deactivate the information and communication access without prior notice if the exhibitor or third parties using the user IDs and passwords assigned to the exhibitor contravene provisions of this contract or legal provisions. Such deactivation shall not affect the entitlement of NürnbergMesse to receive payment of the fee.

The prices quoted apply to provision in single-story stands. For WLAN solutions for multi-story stands, the provision price will apply only to installation on the upper floor.

Reception-impairing stand components and other radio/signal sources in the halls can lead to a considerable deterioration in WLAN signal quality. In the event of this occurring, the exhibitor is not entitled to request a reduction or full reimbursement of the charges.

NürnbergMesse will handle coordination of the complete provision. The connection points are defined by NürnbergMesse. Additional cable laying work on the stand will be charged separately.

9. Customer's own Wireless LAN

Exhibitors are only permitted to set up a WLAN (Wireless Local Area Network) once this has already been expressly registered at NürnbergMesse. A WLAN may cause technical problems. Registration must be applied by using the "Registration for operation of a customer's own WLAN" form provided by NürnbergMesse.

The exhibitor is liable for damage caused by the operation of a WLAN without registration.

The exhibitor agrees to comply with the following conditions.

Non-compliance may result in claims for damages by the organizer or the neighboring exhibitors affected.

The WLAN hardware to be installed must comply with the applicable regulations for radio networks in Europe. Whether the hardware used complies with the above-mentioned regulations can be determined from the documentation supplied by the equipment manufacturer. It is essential that the SSID is named after the exhibitor to enable identification of the WLAN networks. In the event of non-compliance, NürnbergMesse shall be entitled to shut down the network until this requirement is fulfilled.

Should NürnbergMesse discover that interference is caused to its existing networks, it is entitled to request the exhibitor to shut down his radio network. Compliance with this request is obligatory.

Unify Deutschland GmbH & Co. KG is the sole supplier of a WLAN infrastructure for commercial use on the NürnbergMesse site.

NürnbergMesse grants Unify Deutschland GmbH & Co. KG exclusive frequency control over WLAN standards IEEE 802.11b/g in the 2.4 GHz band and IEEE 802.11a/h in the 5 GHz band for the full-coverage WLAN service on the NürnbergMesse site. Only the channel assigned to you by NürnbergMesse is available for you to use throughout the entire trade fair site, for use for all other applications/WLAN networks for operation by ServicePartners of NürnbergMesse and operation of exhibitors' own radio/WLAN networks.

NürnbergMesse reserves the right to refuse registrations or not to approve applications for exhibitors' own WLAN networks, depending on the number and physical assignment per hall. As part of quality assurance measures, unregistered WLAN networks and WLAN networks with excessive transmit power levels will be identified and the operators notified. These networks may possibly be registered after checking or are to be shut down if requested by NürnbergMesse – there is no legal entitlement to registration.

If an amicable solution is not possible, technical measures will be implemented to prevent the illegal operation of such WLAN networks.

10. Return of terminal equipment

Terminal equipment will be collected by NürnbergMesse or its ServicePartner by not later than the last day of dismantling. The dismantling times are defined for each event. If in exceptional cases no collection has been made, the terminal equipment still on the stand is to be returned by the exhibitor to the ServicePartner and confirmation of receipt obtained. In case of doubt, the return of the equipment is to be proved by presenting confirmation of receipt. In exceptional cases, appointments can be arranged by phoning the telephone numbers listed under paragraph 5.

Kitchen appliances, refrigerated, freezing and catering equipment

S2.50

Nuremberg, Germany
14-16.3.2017



embeddedworld2017

Exhibition&Conference
... it's a smarter world

Return to
NürnbergMesse GmbH
MesseService
Messezentrum
90471 Nürnberg
Tel +49 (0) 9 11. 86 06-80 00
Fax +49 (0) 9 11. 86 06-80 01
messe-service@nuernbergmesse.de

Contractor *
Valentin Internationaler Messeservice
GmbH & Co. KG
Industriestraße 39
40822 Mettmann
Tel +49 (0) 21 04. 91 03-0
Fax +49 (0) 21 04. 91 03-91
info@valentin-messeservice.com

Company

Street

Postcode, Town, Country

Tel

Fax

E-mail

Return deadline
14.12.2016

Hall/Stand

Person to contact

Tel

Fax

Invoice address (only if different)

Order (See back of next page for Special Conditions for Services)

VAT ID number of exhibitor:

Refrigerators

Equipment	Description (W x H x D)	Qty.	EUR	Total EUR
Refrigerator with freezer compartment	1. Art. <input type="checkbox"/> 102 , 140 l, 55 x 85 x 60 cm		69.00	
Bottle refrigerator	2. Art. <input type="checkbox"/> 109 , 200 l, 60 x 85 x 60 cm <input type="checkbox"/> 112 , 330 l, 70 x 125 x 70 cm <input type="checkbox"/> 114 , 500 l, 70 x 155 x 70 cm <input type="checkbox"/> 116 , 200 l commercial-(bottle) refrigerator with glazed door <input type="checkbox"/> 120 , 400 l-bottle refrigerator curved-type door, fan-assisted cooling		95.00 133.00 175.00 105.00 158.00	
Refrigerator with freezer compartment "special versions"	3. Art. <input type="checkbox"/> 117 , 100 l "small" refrigerator, 48 x 85 x 50 cm (W x H x D) <input type="checkbox"/> 101 , mini-refrigerator, 44 x 50 x 46 cm (W x H x D)		73.00 73.00	

Equipment	Description (W x H x D)	Qty.	EUR	Total EUR
 *	<input type="checkbox"/> 324 , Coffee-/Cappuccino-/Espresso machine "Bremer Flair" <input type="checkbox"/> * 325 , Coffee-/Cappuccino machine „SAECO Royal One Touch“ with auto-cappuccino function, water tank <input type="checkbox"/> 322 , Coffee-/Cappuccino machine "SAECO Royal Professional" with auto-cappuccino function		540.00 355.00 335.00	

Freezer chests and cabinets

	4. Art. <input type="checkbox"/> 201 , 60 l freezer box (-18°C) <input type="checkbox"/> 202 , 150 l freezer cabinet (-18°C) <input type="checkbox"/> 204 , 300 l freezer cabinet (-18°C) <input type="checkbox"/> 111 , 300 l refrigerator/freezer combination 150 l/150 l <input type="checkbox"/> 206 , 250 l freezer chest (-18°C) with lid <input type="checkbox"/> 209 , 400 l freezer chest (-18°C) with lid <input type="checkbox"/> 213 , 500 l freezer chest (-18°C) with lid		84.00 84.00 147.00 150.00 121.00 157.00 183.00	
--	--	--	--	--

Electrical appliances

	5. Art. <input type="checkbox"/> 302 , 2-plate tabletop cooker <input type="checkbox"/> 310 , kitchenette (2 burners, oven)		33.00 50.00	
Coffee percolator	6. Art. <input type="checkbox"/> * 300 , Coffee machine ECO, glass can: 2 x 1.8l, max. 24 cups <input type="checkbox"/> 303 , 1 x 10 cups		85.00 28.00	

Kitchen appliances

Special exhibition kitchen unit	7. Art. <input type="checkbox"/> 514 , SKJ/U, width 90 cm <input type="checkbox"/> 515 , SKJ/U, width 100 cm		230.00 220.00	
Sink unit	8. Art. <input type="checkbox"/> 505 , sink on right, width 100 cm <input type="checkbox"/> 507 , double sink, width 100 cm <input type="checkbox"/> 508 , double sink, width 120 cm		105.00 110.00 115.00	
Kitchen cupboard	9. Art. <input type="checkbox"/> 509 , worktop unit, width 50 cm <input type="checkbox"/> 510 , worktop unit, width 100 cm <input type="checkbox"/> 512 , kitchen wall cupboard, width 100 cm <input type="checkbox"/> 513 , crockery cupboard, 50 x 187 x 47 cm		55.00 60.00 59.00 55.00	

Kitchen appliances

Dishwasher, 230 V	10. Art. <input type="checkbox"/> 410 , 70-minute program <input type="checkbox"/> 471 , professional, exchangeable basket version (including second basket), 3.2 kW, 9-minute program, 60 x 85 x 60 cm		240.00 475.00	
Dishwasher, professional, 400 V	11. Art. <input type="checkbox"/> 414 , 2-basket version, 7.5 kW, 6-minute program, 60 x 85 x 60 cm <input type="checkbox"/> 416 , exchangeable basket version (including second basket), 7.5 kW, 2-4-minute program, 60 x 85 x 60 cm <input type="checkbox"/> 407 , dishwasher for glasses, professional, 400 V, 7.5 kW, 1-2-minute program, 60 x 69 x 60 cm		570.00 525.00	

* If necessary, NürnbergMesse is entitled to have the service ordered provided by another ServicePartner. In this case, the customer will be notified of the other ServicePartner in good time.

With our authorized signature below, we acknowledge acceptance of all items of the General and Special Terms of Business of NürnbergMesse and the General Terms of Business and the Special Conditions for Services of the ServicePartner.

Place and date

Company stamp and authorized signature

Order: Kitchen appliances (continued)

Equipment	Description (W x H x D)	Qty.	EUR	Total EUR
Dishwasher, professional, 400 V 	11. Art. <input type="checkbox"/> 415 , flow-through basket system with drip tray, rinsing basin, sprinkler, capacity: 40 baskets of 20 plates or 1440 glasses/hour, 7.5 kW, 90/180/240-second program, 205 x 176 x 65 cm <input type="checkbox"/> 413 , extra basket for Art. no.: 415/416 <input type="checkbox"/> 481 , dishwasher, exchangeable basket version, with drying support, 230 / 400 V, 3,6 / 7,5 kW, W x H x D: 60 x 85 x 60 cm <input type="checkbox"/> 485 , professional dishwasher, exchangeable basket version, 230/400 V, 3.6/7.5 kW, 2-9 minute program, W x H x D: 60 x 82.5 x 60 cm		1,150.00	
			22.00	
			590.00	
			525.00	
Electrical appliances	12. Art. <input type="checkbox"/> 426 , sausage warmer, 2 x 10 l, 230 V, 2 x 0.6 kW <input type="checkbox"/> 421 , slicing machine, professional, 230 V, 0.3 kW		130.00	
			150.00	
4-plate cooker	13. Art. <input type="checkbox"/> 403 , with Ceran hob, 4 hotplates and oven (hot air), 400 V, 8 kW		136.00	
Microwave cooker	14. Art. <input type="checkbox"/> 308 , 230 V, 0.7 kW <input type="checkbox"/> 309 , professional, 230 V, 1.5 kW/20 A		69.00	
			215.00	

Refrigeration display equipment, +5°C

	15. Art. Refrigerated cupola "Showmaster" (Refrigeration only at bottom) 230 V, 1.5 kW <input type="checkbox"/> 1050 , stainless steel, Ø 111 cm <input type="checkbox"/> 1053 , stainless steel, Ø 147 cm		1,730.00	
			1,990.00	
	16. Art. Refrigerated cupola "Showmaster" (Refrigeration only at bottom) 230 V, 1.5 kW <input type="checkbox"/> 1051 , white, Ø 111 cm <input type="checkbox"/> 1052 , white, Ø 147 cm		1,640.00	
			1,850.00	
	17. Art. Refrigerated display on trolley, round glass, 230 V, 1 kW <input type="checkbox"/> 1014 , 127 x 111 x 97 cm <input type="checkbox"/> 1015 , 160 x 111 x 97 cm <input type="checkbox"/> 1013 , 193 x 111 x 97 cm		465.00	
			565.00	
			650.00	
	18. Art. Refrigerated display for fish , round glass, on trolley (+/- 0°C), 230 V / 1 kW <input type="checkbox"/> 1016 , 127 x 111 x 97 cm		565.00	

Equipment	Description (W x H x D)	Qty.	EUR	Total EUR
	19. Art. Tapas-Cooling display , GN 8 1/3, (+5°C), 230 V / 0.7 kW <input type="checkbox"/> 1018 , 179 x 25 x 40 cm (GN – bowls)		405.00	
	20. Art. Refrigerated display counter with extra storage compartment, round glass type, 230 V, 1.5 kW <input type="checkbox"/> 1034 , 135 x 128 x 116 cm <input type="checkbox"/> 1033 , 198 x 128 x 116 cm <input type="checkbox"/> 1035 , 261 x 128 x 116 cm		750.00	
			900.00	
			1,100.00	
	21. Art. Display counter with refrigeration storage, curved type, fan cooled, 230 V, 1.5 kW <input type="checkbox"/> 1037 , 120 x 130 x 115 cm <input type="checkbox"/> 1038 , 150 x 130 x 115 cm <input type="checkbox"/> 1039 , 170 x 130 x 115 cm <input type="checkbox"/> 1040 , 200 x 130 x 115 cm		735.00	
			800.00	
			870.00	
			970.00	
	22. Art. Refrigerated island unit , glazed on 4 sides, (+/- 0°C), 230 V, 1.5 kW <input type="checkbox"/> 1102 , 200 x 100 x 105 cm		810.00	
	23. Art. Refrigerated Island , 4-sided glazed, (+5°C), 230 V / 1.5 kW <input type="checkbox"/> 1107 , 151 x 89.5 x 93.5 cm		680.00	
	24. Art. Refrigerated island unit , with sliding glass lid (+/- 0°C), 230 V / 1.5 kW <input type="checkbox"/> 1104 , 185 x 83 x 85 cm <input type="checkbox"/> 1105 , 210 x 83 x 85 cm		770.00	
			820.00	
	25. Art. Refrigeration wall cabinet 230 V, 1.5 kW <input type="checkbox"/> 1056 , 70 x 198 x 71,5 cm ① with illuminated shelves <input type="checkbox"/> 1058 , 135 x 205 x 89 cm ② with illuminated shelves <input type="checkbox"/> 1059 , 102 x 210 x 94 cm ③ <input type="checkbox"/> 1078 , Refrigeration wall cabinet, 133 x 210 x 90 cm ④ <input type="checkbox"/> 1073 , Refrigeration wall cabinet, 190 x 212 x 74 cm ⑤ <input type="checkbox"/> 1055 , Refrigeration wall cabinet with illuminated shelves, 133 x 198 x 71.5 cm ⑥ <input type="checkbox"/> 1071 , Refrigeration wall cabinet with illuminated shelves, ⑦ 195.5 x 198 x 71.5 cm <input type="checkbox"/> 1057 , Mini dairy case with ⑧ light, 65 x 152 x 75 cm, 1 kW		540.00	
			760.00	
			600.00	
			740.00	
			895.00	
			760.00	
			970.00	
			450.00	

With our authorized signature below, we acknowledge acceptance of all items of the General and Special Terms of Business of NürnbergMesse and the General Terms of Business and the Special Conditions for Services of the ServicePartner.

Place and date _____

Company stamp and authorized signature _____

Order: Refrigeration display equipment, +5°C (continued)

Equipment	Description (W x H x D)	Qty.	EUR	Total EUR
	26. Art. <input type="checkbox"/> 1108 , 60 x 175 x 62 cm, o 230 V, 1.5 kW 400 l refrigerator with glass door <input type="checkbox"/> 1081 , 60 x 85 x 60 cm, 1 kW 200 l fan cooled, glass door <input type="checkbox"/> 1088 , 60 x 143 x 60 cm, 1 kW * 275 l fan cooled, glass door <input type="checkbox"/> 1087 , 67 x 192 x 65 cm * Refrigerator with glass door, curved design, 230 V, 1.5 kW, 400 l		380.00 105.00 260.00 420.00	
	27. Art. Refrigerated display case, glazed on 4 sides, rotating display, 230 V, 1.5 kW <input type="checkbox"/> 1080 , 70 x 183 x 70 cm		790.00	
	28. Art. Refrigerated display case, glazed on 6 sides, rotating display, 230 V, 1.5 kW <input type="checkbox"/> 1086 , 101 x 190 x 90 cm		990.00	

Equipment	Description (W x H x D)	Qty.	EUR	Total EUR
	35. Art. Cabinet freezer with glass door, <input type="checkbox"/> o 1276 , 65 x 186.5 x 62 cm, 1 kW, (-18°C) <input type="checkbox"/> * 1275 , 67 x 192 x 65 cm, 230 V, 1 kW, (-18°C), curved design		420.00 450.00	
	36. Art. Freezer display case, glazed on 4 sides, 230 V, 1.5 kW <input type="checkbox"/> 1264 , 70 x 183 x 70 cm		790.00	
	37. Art. Freezer display case, glazed on 6 sides, rotating display, 230 V, 1.5 kW <input type="checkbox"/> 1263 , 101 x 190 x 90 cm		990.00	
	38. Art. Ice-cream freezer (-12°C), 230 V, 1.5 kW <input type="checkbox"/> o 1282 , white, 133 x 117 x 76 cm <input type="checkbox"/> * 1285 , 121 x 126 x 78 cm		595.00 595.00	

Freezing display equipment, -18°C

	29. Art. Island freezer with hinged glass lid, 230 V, 1.5 kW <input type="checkbox"/> 1213 , 123 x 93 x 77 cm		385.00	
	30. Art. Island freezer with sliding glass lid, 230 V, 1.5 kW <input type="checkbox"/> * 1211 , 180 x 103 x 93 cm <input type="checkbox"/> • 1202 , 185 x 90 x 85 cm <input type="checkbox"/> ■ 1210 , 210 x 83 x 85 cm <input type="checkbox"/> * 1212 , 220 x 93 x 93 cm		420.00 770.00 820.00 550.00	
	31. Art. <input type="checkbox"/> 1245 , 102 x 95 x 85 cm Island freezer, glazed 3 sides, 230 V, 1.5 kW <input type="checkbox"/> 1240 , 152 x 113 x 102 cm * Island freezer, glazed 4 sides, with illuminated top unit 230 V, 1.5 kW		505.00 520.00	
	32. Art. Island freezer, glazed on 4 sides, 230 V, 1.5 kW <input type="checkbox"/> 1207 , 200 x 100 x 105 cm		810.00	
	33. Art. Island freezer, 4-sided glazed, (-23°C), 230 V / 1.5 kW <input type="checkbox"/> 1248 , 151 x 89.5 x 93.5 cm		680.00	
	34. Art. Display freezer-showcase, with glazed slide-lid, 230 V, 1.5 kW <input type="checkbox"/> 1216 , 150 x 101 x 90 cm <input type="checkbox"/> 1215 , 170 x 101 x 90 cm <input type="checkbox"/> 1214 , 220 x 101 x 90 cm		775.00 850.00 950.00	

Catering equipment

	39. Art. Hot food display unit, 230 V, 1.5 kW <input type="checkbox"/> 1045 , 84 x 68 x 78 cm <input type="checkbox"/> 1046 , 120 x 68 x 78 cm		240.00 340.00	
	40. Art. Convection steamer (water supply required), 400 V <input type="checkbox"/> 429 , 5 drawers (2/3 catering standard, 4.2 kW), 71 x 60 x 65 cm <input type="checkbox"/> * 442 , 6 drawers (1/1 catering standard, 7.5 kW) with rack, fat filter and hand sprinkler, 90 x 158 x 85 cm		460.00 990.00	
	41. Art. Hot-air steamer, small, 4 2/3, 230 V / 2.2 kW, (GN – bowls), 3/4" inch water supply or 3/4" inch water, ALSO READY WITHOUT WATER SUPPLY <input type="checkbox"/> 468 , 60 x 56 x 57 cm		395.00	
	42. Art. Induction hob, 230 V, 2 kW, Ø 21 cm, including special frying pan and soup pot <input type="checkbox"/> 404 , 38 x 07 x 44 cm		240.00	
	43. Art. Electric deep fryer, 230 V <input type="checkbox"/> 445 , oil capacity 7.5 l, 3 kW, 27 x 26 x 42 cm <input type="checkbox"/> 446 , oil capacity 10 l, 3.4 kW, 31 x 29 x 48 cm		130.00 160.00	

Total (net)

Insurance 3 %

VAT

Total (gross)

With our authorized signature below, we acknowledge acceptance of all items of the General and Special Terms of Business of NürnbergMesse and the General Terms of Business and the Special Conditions for Services of the ServicePartner.

Place and date

Company stamp and authorized signature

**Special Conditions for Services provided
by Valentin Internationaler Messeservice
GmbH & Co. KG**

1. The order and stand plan must be submitted by not later than 14 days before the start of the event. The following surcharges are made for late submission:
Services at fixed prices 25 %
Work at hourly rate 50 %
2. All prices are net prices excluded state and local taxes. Prices include delivery to and pickup from the exhibit stand. This applies to our general trade show area. Special deliveries outside of our normal delivery zone requiring customs are subject to special terms on a case by case basis.
3. **The rent for the general stand equipment will be charged for the entire duration of the fair.** For longer rental periods, special conditions can be arranged. Rental cancellations can be made only up to 14 days prior to the beginning of the fair. The whole rental price will be charged for late cancellations. The rental equipment is available only for the duration of the trade show.
4. The exhibitor's liability for rental equipment will begin upon delivery to the stand and will end with the rental equipment pickup. These terms apply even if the stand is unmanned. The complete rental equipment should be prepared for pickup (including shelves, ice cube trays, glass platters, etc.) and under no circumstances locked up on the pickup date. In the event the rental equipment is not available on the pickup day, contrary to rental agreement, the exhibitor's liability is continued. In this case, it is the exhibitor's obligation to return the merchandise at his own expense. **The rental equipment is not insured. It is the responsibility of the renter to provide insurance.**
5. Claims of incomplete delivery and/or delivery of equipment not in compliance with the contract terms must be submitted within 24 hours of receipt of rental equipment. Later claims will not be accepted. The renter is obligated to report any damage to the equipment caused by the renter or a third party. This also applies in the case of theft. The rental company reserves the right to substitute equivalent merchandise in exceptional cases. This also applies to late orders.
6. The rental equipment remains the property of the rental company and is not subject to seizure. It can be used only for the intended purpose. Any different or extended use is not allowed. The rental company must be notified of any transfer of rental equipment to other locations. Failure to do so will result in the renter accepting all liability. This applies to any damages caused by moving or construction companies contracted by the exhibitors. If any other companies transport the appliances, they will assume all responsibilities for any damages and losses of rental equipment.
7. It is the obligation of the renter to provide adequate ventilation space when setting up refrigeration equipment. Blocking or covering the cooling vent slits of the equipment must be avoided. **For refrigerated and deep-freeze display equipment night tariff electric connection is essential. The defrosting tanks must be emptied regularly. The lessor is not liable for any water damages.** Any contents of cooling equipment must be removed and become the responsibility of the renter. There will be no liability for leftover merchandise. **The rental company Valentin Internationaler Messeservice GmbH & Co. KG is not liable for any damages to the renter's refrigerated merchandise, failures of the equipment or loss of profit.**
8. General Rental Conditions apply to all orders whether verbal, telephoned, faxed, e-mailed or written.
9. The venue of judicial action will be Mettmann, Germany. German laws apply to all foreign orders regardless of any differences between laws.

The total amount was transferred on: _____
to Valentin Internationaler Messeservice GmbH & Co. KG

- Acct. no. 064 16 79 200, sort code 300 800 00 at Commerzbank**
(SWIFT-BIC: DRES DE FF 300,
IBAN: DE 523 008 00000 641679200)
- Acct. no. 000 17 12 934, sort code 301 502 00 at Kreissparkasse**
(SWIFT-BIC: WELADED1KSD,
IBAN: DE44 3015 0200 0001 7129 34)
- Acct. no. 742 18-434, sort code 360 100 43 at Postbank AG**
(SWIFT-BIC: PBNKDEFF, **Essen**)
IBAN DE48 3601 0043 0074 2184 34)

VAT ID no. DE 812 566 888

- We do not require insurance against theft (3 % of rental price)**
- We wish to pay by credit card.**

Issuer: MasterCard American Express
 VISA

Card no.: _____ / _____ / _____

Card verification no.: (The last 3 digits next to the signature on the back of the card or for AMEX 4 digits on the front)

--	--	--	--

Valid until: _____

Holder of card: _____

Terms of payment: Payable in advance by not later than 4 weeks before start of event.



ServicePartner:

Valentin Internationaler Messeservice GmbH & Co. KG
Industriestraße 39, 40822 Mettmann
Postfach 100 445, 40804 Mettmann
Tel +49 (0) 21 04. 91 03-0
Fax +49 (0) 21 04. 91 03-91
info@valentin-messeservice.com
www.valentin-messeservice.com

With our authorized signature below, we acknowledge acceptance of all items of the General and Special Terms of Business of NürnbergMesse and the General Terms of Business and the Special Conditions for Services of the ServicePartner.

Place and date

Company stamp and authorized signature

Nuremberg, Germany
14-16.3.2017



embeddedworld2017

Exhibition&Conference
... it's a smarter world

Return to
NürnbergMesse GmbH
MesseService
Messezentrum
90471 Nürnberg
Tel +49 (0) 9 11. 86 06-80 00
Fax +49 (0) 9 11. 86 06-80 01
messe-service@nuernbergmesse.de

Contractor *
MAS MEDIEN AKTIV SERVICE GmbH
Illesheimer Straße 9
90431 Nürnberg
Tel +49 (0) 9 11. 60 00 93-0
Fax +49 (0) 9 11. 60 00 93-20
info@medien-aktiv-service.de
www.medien-aktiv-service.de

Company

Street

Postcode, Town, Country

Tel

Fax

E-mail

Return deadline
14.12.2016

Hall/Stand

Person to contact

Tel





Fax

Invoice address (only if different)



Order



LED / LCD video walls / LCD displays

Equipment	Designation	Unit	EUR
	LED video wall, indoor Perfect picture without a frame and spaces black face SMD, LEDs superior contrast high color and detail, homogeneous areas of color. Panel size 50 x 50 cm, weight 9 kg		
	1.1 <input type="checkbox"/> Screen size 350 x 200 cm, 28 panels pixel size 2.6 mm , brightness 1200 cd/m ²		on request
	1.2 <input type="checkbox"/> Screen size 450 x 250 cm, 45 panels pixel size 2.6 mm , brightness 1200 cd/m ²		on request
	LCD displays		
	1.3 <input type="checkbox"/> LCD displaywall 165", Full HD, screen size 415 cm, modular system consisting of 3x3 single seamless 55" screens, overall size 365 x 206 cm brightness 700 cd/m ² , overall depth including wall holder 20 cm Of course the displays can be installed single or in totally different configuration.		7,490.00
	1.4 <input type="checkbox"/> LCD displaywall 110", Full HD, screen size 277 cm, modular system consisting of 2x2 single seamless 55" displays, overall size 243 x 137 cm brightness 700 cd/m ² , overall depth including wall holder 20 cm Of course the displays can be installed single or in totally different configuration.		3,510.00
	1.5 <input type="checkbox"/> LCD screen 65" - 105", 4K/UHD resolution 3,840 x 2,160 pixels, including wall holder		on request

LCD displays / accessories

Equipment	Designation	Unit	EUR
	LCD display 90", 70" Full HD resolution 1920 x 1080 pixels, 16:9 LED backlighting 700 cd/m ² no external speakers built-in loudspeakers including wall mount		
	1.6 <input type="checkbox"/> Picture diagonal 228 cm / 90"		2,404.00
	1.7 <input type="checkbox"/> Picture diagonal 176 cm / 70"		1,100.00
	LCD display 55" - 22" Full HD resolution 1920 x 1080 pixels, 16:9 brightness 700 (450) cd/m ² built-in loudspeakers, incl. USB player including wall holder, no table stand		
	1.8 <input type="checkbox"/> Screen size 138 cm / 55"		610.00
	1.9 <input type="checkbox"/> Screen size 121 cm / 48"		495.00
	1.10 <input type="checkbox"/> Screen size 102 cm / 40"		357.00
	1.11 <input type="checkbox"/> Screen size 82 cm / 32"		215.00
	1.12 <input type="checkbox"/> Screen size 55 cm / 22"		149.00
	1.13 <input type="checkbox"/> LCD display 10" HD screen size 25 cm / 10" resolution 1280 x 800 pixels wall mounting on request		130.00
	Touchscreen LCD display 55", 48", 40" Full HD, resolution 1920 x 1080 pixels multitouch up to 6 points, protective glass including wall holder, no table stand control system for Windows 7/8		
	1.14 <input type="checkbox"/> Screen size 138 cm / 55"		863.00
	1.15 <input type="checkbox"/> Screen size 121 cm / 48"		725.00
	1.16 <input type="checkbox"/> Screen size 102 cm / 40"		582.00

If wall mounting is appreciated a special installation wall from the standbuilder will be required for the installation off ALL wall brackets!

Decide on our know-how and the service on the spot with the conception of your exhibition stand, with the choice of the optimal media technology. By purchase of several devices or higher numbers of items, we give you gladly an individual offer.

More information and data sheets are available on our website: www.medien-aktiv-service.de.

We may not be responsible for the client's equipment - particularly computers - that is installed or handed by our employees. No liability for fulfilling problems or damages on hardware or software can be accepted.

ner Si

good time.

With our authorized signature below, we acknowledge acceptance of all items of the General Business and the Special Conditions for Services of the ServicePartner.

Place and date

Company stamp and authorized signature





Order: LCD displays (continued)

Equipment	Designation	Unit	EUR
	InfoStele LCD display 40P/L elegant design with LED strips back-lit color, integrated LCD display 40" screen size 102 cm / 40" resolution 1920 x 1080 pixels brightness 700 cd/m ²		
	1.17 <input type="checkbox"/> InfoStele portrait, 200 x 60 cm		564.00
	1.18 <input type="checkbox"/> InfoStele landscape, 180 x 90 cm		564.00

PC monitors

	2. PC monitors PC monitor 24", 22" Full HD resolution 1920 x 1080 pixels built-in loudspeakers including wall holder or table stand		
	2.1 Screen size 60 cm / 24"		118.00
	2.2 Screen size 55 cm / 22"		112.00

LCD displays / accessoires stand only in conjunction with renting our displays

	3. LCD displays / accessoires		
	3.1 <input type="checkbox"/> Design display stand, integrated cable channel for displays 32" – 70" height up to image centre 170 cm		145.00
	3.2 <input type="checkbox"/> Design stand with angle tray for touchscreen displays 40" – 55" height up to image centre 110 cm		145.00
	3.3 <input type="checkbox"/> Display desk for displays 22" - 32" height up to image centre 120 cm		76.00
	3.4 <input type="checkbox"/> Table stand for displays 32" – 55" height up to image centre 50 cm		55.00

LCD projectors

	4. LCD projector		
	4.1 <input type="checkbox"/> LCD projector , incl. interchangeable lens, horizontal and vertical lens shifting, HD-SDI / HDMI / DVI / VGA / Video, resolution 2K - Full HD 2048 x 1080 pixels contrast 3000:1, brightness 15000 ANSI lumens		3,516.00
	4.2 <input type="checkbox"/> LCD projector , incl. interchangeable lens, horizontal and vertical lens shifting, DVI / HDMI / VGA / component input, resolution, 1920 x 1080 pixels, brightness 7000 ANSI lumens		1,554.00
	4.3 <input type="checkbox"/> LCD projector , incl. interchangeable lens, horizontal and vertical lens shifting, DVI / HDMI / VGA / component input, resolution 1920 x 1200 pixels brightness 5000 ANSI lumens		864.00
	4.4 <input type="checkbox"/> LCD table projector lens 1.2 - 1.9:1, HDMI / DVI / VGA / Video resolution HD 1280 x 800 pixels brightness 3800 ANSI lumens		304.00
	Auxiliary equipment only suitable for the offered projectors Truss ceiling mounting for		
	4.5 <input type="checkbox"/> Up to 5000 ANSI lumens projectors		75.00
	4.6 <input type="checkbox"/> > 7000 ANSI lumens projectors		135.00

Projection screens

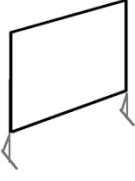
Equipment	Designation	Unit	EUR
	5. Tensioned screens 16:9		
	5.1 <input type="checkbox"/> Front projection 280 x 160 cm		135.00
	5.2 <input type="checkbox"/> Rear projection 280 x 160 cm		175.00
	5.3 <input type="checkbox"/> Front projection 310 x 180 cm		155.00
	5.4 <input type="checkbox"/> Rear projection 310 x 180 cm		215.00
	5.5 <input type="checkbox"/> Front projection 365 x 210 cm		185.00
	5.6 <input type="checkbox"/> Rear projection 365 x 210 cm		267.00
	5.7 <input type="checkbox"/> Front projection 420 x 240 cm		205.00
5.8 <input type="checkbox"/> Rear projection 420 x 240 cm		285.00	
	Further sizes, also in aspect ratio 4:3		on request

Multi media player

	6. <input type="checkbox"/> USB multi media player Full HD, HDMI output MPEG4, H.264, AVI, FLV, WMV, MOV		60.00
---	---	--	-------

Acoustic irradiation / accessories

	7. Acoustic irradiation / accessories		
	7.1 <input type="checkbox"/> Sound system 1 Mixer, equalizer amplifier 2 x 300 watts 2 loudspeakers with stand		410.00
	7.2 <input type="checkbox"/> Sound system 2 Power mixer 2 x 250 watts USB connection 2 loudspeakers with stand (loudspeakers in white available on request)		346.00
	7.3 <input type="checkbox"/> Sound system 3 Mixing amplifier 200 watts 2 small loudspeakers (not suitable for microphone)		186.00
	Accessories:		
	7.4 <input type="checkbox"/> Radio microphone set UHF 1 channel Mixing amplifier 200 watts 2 small loudspeakers (not suitable for microphone)		173.00

Decide on our know-how and on-site service for designing your exhibition stand, with a choice of optimum media equipment.

We will be pleased to make you an individual offer for orders for several devices or larger quantities.

More information and data sheets are available on our website: www.medien-aktiv-service.de.

We assume no guarantee for smooth and high-quality operation of presentations, videos, animations etc. Please send us your test version in advance. We will be happy to advise.

For the customer's own equipment – particularly computers – that is installed or operated by our employees, we do not accept liability for any problems or damage to hardware and software that may occur.

With our authorized signature below, we acknowledge acceptance of all items of the General and Special Terms of Business of NürnbergMesse and the General Terms of Business and the Special Conditions for Services of the ServicePartner.

Place and date

Company stamp and authorized signature

Computer / Tablet PC / Internet terminals

Equipment	Designation	Unit	EUR
 Quoting the favoured software is very appreciated!	8.1 <input type="checkbox"/> Notebook, various types, HDMI, Bluray drive, 15-16" display, WXGA 16:9 / 16:10, Windows 7/8, Office 2010 including Restore, no installation of customer owned software. Variations in configuration and software are subject to changes. Network installation		248.00
	8.2 <input type="checkbox"/> Tablet-PC, different types, with foot or wall holder incl. Restore Network installation		on request on request
	8.3 <input type="checkbox"/> Internet terminal, ALU design, silver gray, metal keyboard, trackball, 17" touch screen, speaker, internal PC, Windows 7, manipulation-proof Internet software Please order suitable Internet access from Unify Deutschland GmbH & Co. KG, the ServicePartner of NürnbergMesse using Form S2.40.		669.00

ServicePartner:

MAS MEDIEN AKTIV SERVICE GmbH
Illesheimer Straße 9, 90431 Nürnberg
Tel +49 (0) 9 11. 60 00 93-0
Fax +49 (0) 9 11. 60 00 93-20
info@medien-aktiv-service.de, www.medien-aktiv-service.de

OUR COMPETENCE FOR YOUR SUCCESS

Prices refer to the total duration of the fair (plus VAT at the statutory rate).
 The prices quoted include delivery, assembly, connection of equipment ready for operation and collection of the equipment. If the customer's own equipment is to be installed, this must be available during assembly.
 Instructions for use and handing over the equipment to a person appointed by the customer take place immediately after assembly.
 Services provided during the event that are not covered by the guarantee (e.g. incorrect operation of equipment) will be charged separately.
 Additional services (e.g. delivery of cable in advance, laying special cables) are charged according to outlay.
 Technician for additional services @ EUR 48 per hour.
 Please ask for additional equipment or services desired. We'll be pleased to make you an individual offer.

Orders with invoice addresses abroad can only be processed after receipt of payment. You will receive our confirmation of order and bank details for the advance remittance promptly.

Cash remittance after receipt of acknowledgment/invoice (total amount plus VAT at the statutory rate)

Charge to following credit card:

Issuer: MasterCard VISA

Card holder: _____

Card no.: _____ / _____ / _____

Card verification no.: (The last 3 digits on back of card)

--	--	--

Valid until: _____

If necessary payment will be carried out by the service bureau during the fair.





Our general terms and conditions shall apply. Jurisdiction shall be at the place of performance. i.e. Nuremberg.

Terms of conditions see last page.

We assume no guarantee for smooth and high-quality operation of presentations, videos, animations etc. Please send us your test version in advance. We will be happy to advise.

For the customer's own equipment – particularly computers – that is installed or operated by our employees, we do not accept liability for any problems or damage to hardware and software that may occur.

Cameras, other

	9.1 <input type="checkbox"/> Full HD camera professional Full HD-camcorder AVCHD on SDHC memory card HDMI-output, tripod, rechargeable battery		465.00
	9.2 <input type="checkbox"/> Full HD dome camera PANASONIC integrated camera in pan/tilt head, size only 18 x 17 cm 18-fold lens, remote control		on request
	9.3 <input type="checkbox"/> Video documentation of the stand Camera man with professional equipment in Full HD quality Shooting of the stand and samples (up to 6 hours) Production of an image film including logo and text overlays (up to 8 hours) Extra time upon consultation		1,600.00
	9.4 <input type="checkbox"/> Internet Live-Stream TV-live coverage via Internet from the stand, more than 1000 users at the same time, camera, encoder, etc. at least. 2Mbit/s Uplink required		on request

Camera security system

	10.1 <input type="checkbox"/> Video security monitoring at the booth. According to the Technical Guidelines NürnbergMesse. No data storage. Security camera 10" monitor, UPS battery in case of power failure		686.00
	10.2 <input type="checkbox"/> Video security surveillance with multiple cameras and monitors as Split Screen		on request

With our authorized signature below, we acknowledge acceptance of all items of the General and Special Terms of Business of NürnbergMesse and the General Terms of Business and the Special Conditions for Services of the ServicePartner.

Place and date _____

Company stamp and authorized signature _____

Special Conditions for Services provided by MAS MEDIEN AKTIV SERVICE GmbH (Media and event equipment)

1. Subject of contract

The rental of equipment is governed by the rental conditions stated below, which are acknowledged on placing the order. Orders take effect by not later than the time of delivery of the equipment and the actual provision of the services.

2. Rental period

The rental period is restricted to the duration of the respective exhibition including the installation and dismantling time, commences on handover of the equipment to the renter and ends on return of the equipment to the ServicePartner.

3. Transport, delivery, installation and dismantling

The ServicePartner is entitled to withdraw from the rental contract in case of unforeseen events beyond its control such as strikes, lock-outs, damage due to accidents, traffic conditions, operational disturbances, etc., regardless of whether such events occur at the ServicePartner or at one of its suppliers. Claims for damages by the renter are excluded in case of such withdrawal from the contract.

The equipment is usually installed on the day before the dismantling after the close of the exhibition.

4. Use of rented goods

The rented goods remain the sole property of the ServicePartner. The renter is to use them carefully, fulfill all obligations connected with the transfer for use and the use and maintenance of the rented goods and follow the instructions for use issued by the ServicePartner.

5. Damages and liability

Claims for damages by the customer, renter or a third party due to failure/partial failure of the rented goods, force majeure or direct or indirect damages to assets, property or persons are not admissible. Such claims are also not admissible against the ServicePartner's employees or representatives.

The renter assumes unlimited liability for the rented goods and all accessories during the rental period. This liability also covers accidental damage and incorrect handling and operation.

The return of the equipment does not constitute confirmation by the ServicePartner that the equipment has been returned in a serviceable condition. The ServicePartner expressly reserves the right to carry out a detailed check of the equipment after its return.

We may not be responsible for the client's equipment – particularly computers – that is installed or handed by our employees.

No liability for fulminating problems or damages on hardware or software can be accepted.

6. Withdrawal of renter from contract

In case of the renter withdrawing from the rental contract for any reason whatsoever, the declaration of withdrawal must be received by the ServicePartner not less than 14 days prior to the agreed date of commencement of the rental contract. The renter is to bear the cost of any loss of rental charges caused by withdrawal from the contract less than 14 days prior to its commencement.

7. Insurance

The equipment is not insured. The renter is liable for the cost of new equipment in case of damage.

Additionally, we advise to include liability in the exhibitors insurance.

8. Payment

All prices for rental goods and services are subject to the current rate of value added tax. The invoice is due for payment immediately without deductions.

The costs for money transfer from abroad will be charged. The invoice can be settled before the start of the exhibition or payment will be collected during the exhibition at the stand. Cheques or credit cards (MasterCard, VISA) are accepted.

9. Final provision

Amendments to this contract must be made in writing. The effectiveness of the remaining provisions is not effected in case of a provision of this contract becoming null and void. The place of jurisdiction and fulfillment is Nürnberg.

Nuremberg, Germany
14–16.3.2017



embeddedworld2017

Exhibition&Conference
 ... it's a smarter world

Return to
 NürnbergMesse GmbH
 MesseService
 Messezentrum
 90471 Nürnberg
 Tel +49 (0) 9 11. 86 06-80 00
Fax +49 (0) 9 11. 86 06-80 01
 messeservice@nuernbergmesse.de

Contractor *
 pave GmbH
 Büro Messezentrum, SPC 1.55
 Tel +49 (0) 9 11. 86 06-60 11
 Fax +49 (0) 9 11. 86 06-60 12
 messe@pave.de

Company _____

Street _____

Postcode, Town, Country _____

Tel _____

Fax _____

E-mail _____

Return deadline	Hall/Stand
14.12.2016	
Person to contact _____	
Tel _____	
Fax _____	
Invoice address (only if different) _____	

Order

VAT ID number of exhibitor:

Would you like to put the spotlight on your stand with the right **sound** and **lighting** or **multimedia** and plan background music, speakers, suitable lighting or a visual display on your stand? **Then simply book the right full-service package.**
 Do you need help or ideas on choosing the right package? Just contact us, we'll be pleased to help!

Media packages

- Display package**
 Contains a full HD display with source computer and display stands for playing presentations, videos etc. Please select the desired display size. The package naturally includes cabling, assembly and dismantling.
 - 40"-display package EUR 620.00
 - 46"-display package EUR 750.00
 - 55"-display package EUR 870.00
- Security package** EUR 1,900.00
 This security package contains camera surveillance and – following approval – recording. The live camera picture is shown permanently on a display, so you have a full view of your stand at any time, which is useful for aspects such as fire prevention or for information in case of theft.
- Presentation package** EUR 2,390.00
 This contains a 7,000 ANSI lumens projector including source computer. Please note that this projector can only be used in a darkened area. You can use it to show PowerPoint presentations, videos, pictures, etc. on the screen supplied with the package. The package naturally includes suitable cabling and assembly and dismantling by an experienced media technician.
- Individual media equipment concept**
 You tell us your wishes and ideas – and we contact you without delay to discuss the optimum concept and design a successful multimedia show for your product presentation: messe@pave.de.

Lighting packages

- Speaker lighting package** EUR 692.00
 Contains spotlights on tripods, which are ideal for illuminating a speaker. The service includes delivery, assembly and dismantling of the equipment.
- Stand lighting package**
 Contains spotlights for wide-area illumination of your stand. The ambience lighting also included in the package gives your stand a high-quality and attractive visual appeal.
 - up to 21 m² EUR 2,000.00
 - up to 40 m² EUR 3,400.00
- Stage lighting package**
 Contains spotlights for wide-area illumination of your stage. You also get colored lighting and effect lighting to ideally highlight the stage and stage activity.
 - up to 24 m² EUR 3,046.00
- Individual lighting concept**
 You tell us your wishes and ideas – and we contact you without delay to discuss the optimum concept that is guaranteed to make your presence at the exhibition a visual success: messe@pave.de.

* If necessary, NürnbergMesse is entitled to have the service ordered provided by another ServicePartner. In this case, the customer will be notified of the other ServicePartner in good time.
 With our authorized signature below, we acknowledge acceptance of all items of the General and Special Terms of Business of NürnbergMesse and the General Terms of Business and the Special Conditions for Services of the ServicePartner.

Place and date

Company stamp and authorized signature

Order: (continued)

Public address system packages

- Sound Package I (up to 50 m²)** EUR 830.00
The "Sound Package I" gives you a set comprising one of our high-quality event racks with sound mixer console, amplifier, matching speakers and a radio microphone. You can play background music from your laptop, mp3 player or CD player. A radio microphone amplifies any presentations or speeches. The package includes assembly and dismantling. The system is set up by a sound technician ready for use.
- Sound Package II (up to 100 m²)** EUR 1,800.00
This package is the perfect public address system for your stand. The event rack with digital mixer console, amplifier, speakers and a dual-channel radio microphone path caters for every wish. The package includes assembly and dismantling. The system is set up by a sound technician ready for use.

- Individual sound concept**
Tell us your wishes and ideas – we'll contact you without delay to get your message across to the visitors with the right sound: messe@pave.de.
- Stand Party Package I (up to 150 m²) 1 evening** EUR 2,900.00
This package, comprising a premium event rack with digital mixer console, amplifier and dual-channel wireless microphone system and speakers, provides the ideal sounds for your stand party. The package also includes LED lights that dramatically illuminate and highlight your stand for the event. The package includes assembly and disassembly and support from an event technician throughout the entire party, leaving you free to focus completely on your customers. We will of course consult with you and if necessary other service providers to ensure the assembly and dismantling work causes minimal interference with trade fair operations.

If you wish to place the public address system in experienced hands, why not book one of our sound technicians for looking after the system during the exhibition from **EUR 300/day**:

- Sound technician for support throughout the exhibition **EUR 900.00**



With our authorized signature below, we acknowledge acceptance of all items of the General and Special Terms of Business of NürnbergMesse and the General Terms of Business and the Special Conditions for Services of the ServicePartner.

Place and date

Company stamp and authorized signature

Technical equipment – just-in-time delivery to your stand.

(Price each for duration of exhibition, incl. delivery/collection, without installation)

Forgotten/lost/faulty? You've forgotten or lost something or have a fault on site? Whether a small adapter, distributor, cable or large display, just contact us! We'll help you as quickly as possible: Tel +49 (0) 9 11. 86 06-60 11.

Media equipment

(Price each for duration of exhibition, incl. delivery/collection, without installation)

Displays

Do you need a display for presenting contents to your visitors?

Select the size of display, including wall mount, which you require here. If the size you need is not listed or you need a touch version of the required display, just contact us!

- | | | | |
|--------------------------------|----------------------------|-----|----------|
| <input type="checkbox"/> _____ | 24" LCD Display 16:10 | EUR | 180.00 |
| <input type="checkbox"/> _____ | 40" LCD Display 16:9 | EUR | 340.00 |
| <input type="checkbox"/> _____ | 46" LCD Display 16:9 | EUR | 520.00 |
| <input type="checkbox"/> _____ | 55" LCD Display 16:9 | EUR | 850.00 |
| <input type="checkbox"/> _____ | 70" LCD Display 16:9 | EUR | 1,350.00 |
| <input type="checkbox"/> _____ | 108" LCD Display 16:9 | EUR | 6,590.00 |
| <input type="checkbox"/> _____ | Display stands up to 70" * | EUR | 100.00 |

* can only be booked together with a display

Source equipment

Do you need a source computer for your presentations, videos etc.? Choose the right source device here. We'll be pleased to answer any questions.

- | | | | |
|--------------------------------|--------------------------|-----|----------|
| <input type="checkbox"/> _____ | Laptop | EUR | 345.00 |
| <input type="checkbox"/> _____ | Ultra-compact PC | EUR | 180.00 |
| <input type="checkbox"/> _____ | Workstation PC | EUR | 1,385.00 |
| <input type="checkbox"/> _____ | Blu-ray Player | EUR | 56.00 |
| <input type="checkbox"/> _____ | SD Card Player | EUR | 118.00 |
| <input type="checkbox"/> _____ | Apple MacBook Pro | EUR | 450.00 |
| <input type="checkbox"/> _____ | AppleTV (including iPad) | EUR | 180.00 |

Projection

Would you like to give a presentation for your visitors and are looking for the right presentation equipment? Choose the required projector here. For selecting the right lens, please tell us the distance from the projector to the screen/projection surface.

Distance from projector to screen: _____ m

- | | | | |
|--------------------------------|-------------------------------------|-----|----------|
| <input type="checkbox"/> _____ | 2,500 ANSI lumens/LCD/XGA | EUR | 228.00 |
| <input type="checkbox"/> _____ | 7,000 ANSI lumens/1-chip DLP/WUXGA | EUR | 1,938.00 |
| <input type="checkbox"/> _____ | 12,000 ANSI lumens/3-chip DLP/WUXGA | EUR | 4,150.00 |

Incidentally, we stock projectors of all kinds and sizes. Do you need another brightness category or a certain resolution? We'll be pleased to answer any questions!

Screens

Do you need another projection screen for your event? Select the right size here. We stock all common screen sizes and formats. Please contact us if the size you need is not listed here! (Price each)

- | | | | |
|--------------------------------|-------------------------|-------------------------|--------|
| <input type="checkbox"/> _____ | Screen 310x180 cm, 16:9 | EUR | 195.00 |
| <input type="checkbox"/> _____ | Screen 447x260 cm, 16:9 | EUR | 298.00 |
| <input type="checkbox"/> _____ | Screen 280x210 cm, 4:3 | EUR | 228.00 |
| <input type="checkbox"/> _____ | Screen 400x300 cm, 4:3 | EUR | 228.00 |
| <input type="checkbox"/> _____ | Screen 600x450 cm, 4:3 | EUR | 580.00 |
| <input type="checkbox"/> _____ | Other size: _____ | Price on request | |

Public address equipment

Please see our sound packages.

Do you need single public address components or individual advice? Just contact us! messe@pave.de.

Can't find the right equipment? Write to us. We can get (almost) everything for you in our partner network: messe@pave.de.

Lighting

(Price each for duration of exhibition, incl. delivery/collection, without installation)

Do you need spotlights for lighting your stand or would you like to highlight your company logo?

With our authorized signature below, we acknowledge acceptance of all items of the General and Special Terms of Business of NürnbergMesse and the General Terms of Business and the Special Conditions for Services of the ServicePartner.

Conventional spotlights

For direct orders please enter the desired number of spotlights on the lines.

- | | | | |
|--------------------------------|---------------------|-----|-------|
| <input type="checkbox"/> _____ | Fresnel lens 650 W | EUR | 35.00 |
| <input type="checkbox"/> _____ | Fresnel lens 1000 W | EUR | 45.00 |
| <input type="checkbox"/> _____ | Fresnel lens 2000 W | EUR | 68.00 |

We offer all the common conventional spotlights – from Par spotlight and Fresnel lens to profile spotlight. Just ask, we'll be pleased to advise and prepare an individual lighting concept for you: messe@pave.de.

LED lighting

Planning energy-efficient exhibitions is becoming more and more important. We successfully use high-quality LED lighting for this. This not only saves you electricity costs – the color mix is also completely flexible and can be adjusted to your individual requirements at short notice.

Please select the articles and state the quantity ordered:

- | | | | |
|--------------------------------|----------------------------|-----|--------|
| <input type="checkbox"/> _____ | Mini LED Par RGB | EUR | 13.00 |
| <input type="checkbox"/> _____ | LED Washlight (floodlight) | EUR | 170.00 |

An LED floodlight is ideal for illuminating large areas.

_____ Battery LED Floor Lamp (package of 8) EUR 390.00
These lamps give you absolute flexibility – no cable, no power connection! The clever thing about them: the lamps are also controlled from the central lighting console.

_____ LED Par RGB EUR 45.00
These LED Pars are perfect as power-saving and versatile alternatives to conventional Par lamps. Desired color, color gradients, ambience lighting – for flexible use.

_____ LED Studio Par White EUR 59.00
We recommend the LED-based version instead of the conventional Studio Pars as they can be used to produce both artificial and daylight temperatures. Highlight your products with the optimum color temperature and save electricity costs at the same time.

Please contact us if you need help in choosing the right products. We'll be pleased to advise and prepare the optimum lighting concept to make your exhibition presence something special.

Rigging

(Price each for duration of exhibition, incl. delivery/collection, without installation)

Four-point truss e.g. Eurotruss FD34

- | | | | |
|--------------------------------|--------|---|--|
| <input type="checkbox"/> _____ | 3.00 m | <input type="checkbox"/> Silver EUR 35.00 | <input type="checkbox"/> Black EUR 35.00 |
| <input type="checkbox"/> _____ | 2.00 m | <input type="checkbox"/> EUR 23.00 | <input type="checkbox"/> EUR 33.00 |
| <input type="checkbox"/> _____ | 1.00 m | <input type="checkbox"/> EUR 12.00 | <input type="checkbox"/> EUR 20.00 |
| <input type="checkbox"/> _____ | 0.50 m | <input type="checkbox"/> EUR 12.00 | <input type="checkbox"/> EUR 20.00 |
| <input type="checkbox"/> _____ | 0.29 m | <input type="checkbox"/> EUR 12.00 | <input type="checkbox"/> EUR 12.00 |

Three-point truss e.g. Eurotruss FD33

- | | | | |
|--------------------------------|--------|---|--|
| <input type="checkbox"/> _____ | 3.00 m | <input type="checkbox"/> Silver EUR 20.50 | <input type="checkbox"/> Black EUR 20.50 |
| <input type="checkbox"/> _____ | 2.00 m | <input type="checkbox"/> EUR 13.50 | <input type="checkbox"/> EUR 13.50 |
| <input type="checkbox"/> _____ | 1.00 m | <input type="checkbox"/> EUR 7.00 | <input type="checkbox"/> EUR 7.00 |
| <input type="checkbox"/> _____ | 0.50 m | <input type="checkbox"/> EUR 7.00 | <input type="checkbox"/> EUR 7.00 |
| <input type="checkbox"/> _____ | 0.29 m | <input type="checkbox"/> EUR 7.00 | |

Two-point truss e.g. Eurotruss FD32

- | | | | |
|--------------------------------|--------|---|--|
| <input type="checkbox"/> _____ | 3.00 m | <input type="checkbox"/> Silver EUR 12.00 | <input type="checkbox"/> Black EUR 12.00 |
| <input type="checkbox"/> _____ | 2.00 m | <input type="checkbox"/> EUR 9.00 | <input type="checkbox"/> EUR 9.00 |
| <input type="checkbox"/> _____ | 1.00 m | <input type="checkbox"/> EUR 5.00 | <input type="checkbox"/> EUR 5.00 |

Motors

- | | | | |
|--------------------------------|---------------------------|-----|--------|
| <input type="checkbox"/> _____ | Chain hoist D8+0.50t 18 m | EUR | 135.00 |
| <input type="checkbox"/> _____ | Chain hoist D8+0.25t 18 m | EUR | 135.00 |

We also hold sufficient quantities of suitable truss corners, special sizes or truss circles. Please ask!

Specials

You have an idea? You're looking for an idea? pave's specials always offer the right solution.

I am interested in the following specials – please send detailed information to the following e-mail address: _____

LED walls – innovative advertising!

Whether for image films, product presentations or live pictures, LED walls are both an eye-catcher on your stand and an information medium for your customers. The high light intensity means the display is not even affected by light shining in from outside – for use in exhibition halls this is a quality advantage over the use of projectors that should not be underestimated. Many applications for our customers speak for our experience; just call us, we'll be pleased to advise.

Frameless display walls

Frameless LCD monitors can be stacked to make large pictures possible in a better quality than ever before and at a low price. Display walls are an excellent and professional solution for all kinds of presentations. We also offer you display walls with touch screens for interaction with exhibition visitors. You haven't got any suitable touch applications for your own products yet? We can also help you here with our own software department pave.media.

Streaming

Show the whole world what you're doing on your stand at the moment or present your keynote speaker live. We offer you a technically and legally perfect live stream on the Internet. A wide variety of applications are possible. For example, what about a virtual press conference?

Touch applications

Product and company information in various file formats integrated into a digital interface and available offline combined with multi-touch and zoom effects is an eye-catching and professional possibility for a presentation that visualizes your product down to the smallest detail – ideal for your presentation during the exhibition and afterwards too, e.g. for use by your sales staff for visits to customers. Our in-house software department pave.media will be pleased to advise.

Individual content creation

You have a lot of data material but don't know how to put it together to create an attractive exhibition presentation? Your message and our creativity produce the right mix for a professional presentation. In combination with our live media servers we'll top your expectations!

Photo tool

Stand photos as mementoes – with a facility for direct upload to your home page or facebook page. Show yourself and your stand visitors for everyone to see that it pays to be there. Photos can also be printed with your advertising message on the stand – a very personal give-away that doesn't land in the waste paper basket so quickly.

Film production

Production of an image film? Lively product presentation? Documentation of your exhibition presence? Contact us – we have excellent equipment coupled with artistic film creativity.

iPad – trendy, versatile and more than a gimmick

Go with the spirit of the times and give the visitor the useful data and features of your product clearly and precisely in a short space of time. You can also provide picture or video elements for detailed views or transfer your catalog or other information to the visitor's smartphone via a QR code. We'll be pleased to supply the iPads already pre-installed on your stand on request.

Special Conditions for Services provided by pave GmbH (Media and event equipment)

1 Prices, invoicing and payment terms

(1) The stated net prices are subject to VAT at the statutory rate applicable at the time of providing the service and apply for the whole duration of the event. They include delivery, assembly and connection of the equipment and its collection after the end of the exhibition.

The equipment provided is handed over to a person nominated by the customer immediately after assembly and instructions for use are given at the same time. This does not apply to individual offers that include support during the exhibition. The customer must comply with the instructions for use issued by pave GmbH.

(2) Please note: The following surcharges will be made for orders and orders with incomplete information received less than 14 days before the start of the event:

Rental equipment/ material:	25 %
Personnel (assembly, support etc.):	50 %

(3) Extra transfer charges are payable for exhibitors based outside Germany who pay invoices by bank transfer. An additional fee of EUR 16.50 will be charged for international transfers outside the EUR (€) zone. This amount is not payable if the transfer charges are paid by the customer.

(4) A processing fee of EUR 50 plus VAT at the statutory rate will be charged for issuing a new invoice due to incorrect information provided by the applicant (e.g. lack of a valid VAT ID, company name etc. for customers outside Germany). This fee will be included in the new invoice to be issued.

(5) The usual rate of bank interest on arrears will be payable in the event of late payment of the amount invoiced.

2 Services & hourly rates

(1) Services provided during the exhibition that are not connected with a complaint (operation fault for which pave GmbH is responsible) will be charged extra. Services or additional services (e.g. advance deliveries specifically for assembly etc.) will be charged at EUR 45/hour.

(2) The customer will receive an invoice on receipt of the order form. This invoice acts as confirmation of the order. The contract is then concluded with pave GmbH. The full amount of the invoice is payable before the start of assembly. For orders placed at short notice, provided these can be executed, the contract is also concluded by not later than the time of delivery of the equipment and the actual provision of the services. This order form is not an enquiry form, but constitutes an order if not canceled by pave GmbH.

(3) If the full amount of the invoice is not paid in advance or at the stated time, we reserve the right to collect any outstanding amount on the stand during the exhibition, when only cash payment is possible.

(4) Assembly usually takes place the day before the event and dismantling directly after the end of the event. Earlier assembly/ later dismantling must be agreed separately and may be subject to extra cost.

(5) Unless otherwise indicated, all the stated items are only provided on a rental basis. The rental goods are not suitable for use in the outdoor area.

(6) The package offers are standard as stated, can be combined with each other and supplemented with individual items. Package services not required by the exhibitor cannot be deducted from the package price. Should we decide on the basis of the customer's requirement that the material contained in the packages is not suitable for the desired application purpose, we reserve the right not to provide our equipment.

(7) If equipment is to be wall-mounted, a sufficiently strong wall panel must be provided by the customer.

3 Damage & liability

(1) Our equipment conforms to the latest state of the art. Nevertheless, we cannot guarantee completely fault-free operation of the systems used. We therefore do not accept any liability for possible damage caused by failure of the systems. Claims for damages cannot be asserted. We recommend the use of back-up or redundant systems if required.

Special clause for plasma displays: To avoid burn-in effects with plasma displays, mainly moving picture sequences should be shown. Logos or graphics must not be used as still pictures for longer than five minutes. Slight burn-in effects can be cleared by permanent operation with a white image. For displays with such a slight burn-in effect, a fee of EUR 150 per day will be charged for repairing the damage (time required: usually 5 – 7 days)

(2) The renter (customer) is liable for all damage caused to the rented equipment. The rental charge does not normally include insurance. We'll be pleased to insure material for you, for which we charge you 5 % of the net material sales. Please send an e-mail to messe@pave.de if you would like to use this service.

(3) If the rented equipment is returned late, the full daily rate will be payable for each day or part day.

(4) Any missing or damaged rental goods will be charged at the cost of replacement. The renter's liability for the rental goods commences on delivery and ends on collection by pave GmbH (even if the renter has already left the stand), but not later than up to 24 hours after the end of the exhibition.

(5) We cannot guarantee the proper functioning of the customer's own feeder systems. We also accept no guarantee for the smooth running and high-quality of presentations, videos, animations, etc. if these are not provided by us. Please send us a test version in advance. We'll be pleased to advise.

(6) Unforeseen occurrences (e.g. strike, lockout, accident damage, traffic conditions, operational disturbances, etc.) beyond the control of pave GmbH, regardless of whether at pave GmbH or at one of our suppliers, entitle pave GmbH to withdraw from the rental contract under exclusion of claims for damages by the renter.

(7) Claims for damages by the customer, renter or third parties due to failure/partial failure of the rental goods, force majeure or direct or indirect damage to financial assets, property or persons are excluded, also against our staff or persons appointed by us. The renter accepts unlimited liability for the rented equipment and all accessories during the rental period, including for accidental damage and for incorrect handling and operation. pave GmbH does not confirm that equipment returned is free of faults and expressly reserves the right to subsequently inspect the equipment in detail.

4 Cancellation of order

pave GmbH must be notified in writing if the event or individual parts of the event is/are canceled. The following cancellation fees will be payable: no fee if notification is made up to 8 days before the event, 50 % of the net amount of the order for cancellation 7 days before the start of the event, and the total net amount for cancellation 2 days before the start of the event.

5 Safety regulations

The customer is expressly responsible for compliance with the applicable safety regulations (Venue Regulations VstättV, Fire Prevention Regulations, Technical Regulations, etc.), unless pave GmbH is explicitly appointed as responsible for compliance with the safety regulations and the preparation of a safety concept.

6 Final provisions

(1) Amendments to this contract shall be made in writing. If a provision of this contract becomes void, this shall not affect the effectiveness of the remaining provisions.

(2) The place of jurisdiction and fulfillment, including for debt recovery proceedings, is Nürnberg for both parties.

As of: 21.05.2014

Nuremberg, Germany
14–16.3.2017



embeddedworld2017

Exhibition & Conference
... it's a smarter world

Company _____

Street _____

Postcode, Town, Country _____

Tel _____

Fax _____

E-mail _____

Return to
NürnbergMesse GmbH
MesseService
Messezentrum
90471 Nürnberg
Tel +49 (0) 9 11. 86 06-80 00
Fax +49 (0) 9 11. 86 06-80 01
messeservice@nuernbergmesse.de

Contractor
R+F oHG
Agentur für Messe- &
Gastronomiedienstleistungen
Erlenstegenstraße 5, 90491 Nürnberg
Tel +49 (0) 9 11. 95 64 87 84
Fax +49 (0) 9 11. 95 64 87 89
info@rf-ohg.de

Return deadline
immediately

Hall/Stand

Person to contact _____

Tel _____

Fax _____

Invoice address (only if different) _____

Order

The quick and easy way to collect all your leads!

We herewith order the following VisitorScan packages

- | | | | | | |
|--------------------------|----------------------------|------------|-----|----------|------------|
| <input type="checkbox"/> | MS VisitorScan Basic | Price/each | EUR | 350.00 | Qty. _____ |
| <input type="checkbox"/> | MS VisitorScan ReadyForUse | Price/each | EUR | 590.00 | Qty. _____ |
| <input type="checkbox"/> | MS VisitorScan Extra | Price/each | EUR | 1,700.00 | Qty. _____ |
| <input type="checkbox"/> | Additional scanner | Price/each | EUR | 150.00 | Qty. _____ |

MS VisitorScan Basic

- 1 bar code scanner
- Questionnaire with up to 20 user-definable attributes
- As soon as scanner data has been read at the service station you will be sent the scanned addresses and other data once a day by e-mail
- The equipment has to be **collected from and returned to a service station**

MS VisitorScan ReadyForUse

- 1 bar code scanner
- 1 Laptop including pre-installed software
- Questionnaire with up to 20 user-definable attributes
- 1 Internet connection (LAN – single user access)
- As soon as the data has been read using the laptop the scanned addresses and other data will be sent by e-mail
- Captured data sent in a format of your choice (XLS, VCard, CSV, and PDF) after the last day of the exhibition
- Delivery of hardware including system training and support
- Equipment will be collected after the exhibition

MS VisitorScan Extra

- 1 bar code scanner
- 1 Laptop including pre-installed software
- 1 A4 scanner for capturing the questionnaires
- 1 Internet connection (LAN – single user access)
- 1 laser printer
- User-defined reports (max. 2 x A4 sheets)
- As soon as the data has been read using the laptop, you will be sent the scanned addresses and other data by e-mail
- Captured data sent in a format of your choice (XLS, VCard, CSV, and PDF) after the last day of the exhibition
- Delivery of hardware including system training and support
- Equipment will be collected after the exhibition

VAT ID number of exhibitor:

--	--	--	--	--	--	--	--	--	--	--	--	--	--	--	--	--	--	--	--

Please note:

- The undersigned confirms possession of the appropriate authorization for placing the order. The recipient of this service is always the exhibitor, who receives a copy of this order from the undersigned.
- The invoice can be sent to a different invoice address. Please note that the final invoice is issued by NürnbergMesse GmbH. A processing fee of EUR 35 per invoice will be charged for changing the address after receipt of the invoice.
- Orders can be cancelled free of charge prior to invoicing. A processing fee of EUR 50 per invoice will be charged for cancellation after invoicing. The full rental charge will be payable if the package is not cancelled until the date of delivery.
- You are liable for loss of or damage to devices until their return, which must be confirmed by a signed receipt. Any costs incurred plus an administrative fee of EUR 35 shall be borne by the person placing the order.
- The undersigned agrees that any visitor/exhibitor data transferred to him may only be scanned with the consent of the visitor/exhibitor and for the previously agreed purpose of personal data exchange.
- As part of the registration process, the exhibitor agrees to observe the individual's right to informational self-determination, i.e. to determine the disclosure and use of his personal data, and is governed by the data protection directives of the respective German state/country.
- NürnbergMesse GmbH accepts no liability for any damage during the rental period. An exhibition insurance policy is certainly recommended, or better still, a stand security guard.

Please fill in for payment by credit card:

Issuer : MasterCard VISA American Express

Card no.: : _____ / _____ / _____

Card verification no.: (The last 3 digits next to the signature on the back of the card or for AMEX 4 digits on the front)

--	--	--	--

Expiry date : _____

Holder of card: _____

We authorize NürnbergMesse GmbH to debit the invoice amount from the above-mentioned credit card.

Signature: _____

All the stated prices are subject to the addition of VAT at the statutory rate. Our authorized signature below confirms our acceptance of all the stated terms and conditions.

Place and date

Company stamp and authorized signature

Nuremberg, Germany
14–16.3.2017



embeddedworld2017

Exhibition&Conference
... it's a smarter world

Return to
NürnbergMesse GmbH
MesseService
Messezentrum
90471 Nürnberg
Tel +49 (0) 9 11. 86 06-80 00
Fax +49 (0) 9 11. 86 06-80 01
messe-service@nuernbergmesse.de

Contractor *
Messebau Wörnlein GmbH
Messezentrum
90471 Nürnberg
Tel +49 (0) 9 11. 81 74 49-0
Fax +49 (0) 9 11. 81 74 49-25
info@woernlein.de
www.woernlein.de

Company _____

Street _____

Postcode, Town, Country _____

Tel _____

Fax _____

E-mail _____

Return deadline _____
immediately

Hall/Stand _____

Person to contact _____

Tel _____

Fax _____

Invoice address (only if different) _____

Order

Fire extinguishers for rental stands, **for rental**, price for the duration of the event, including delivery and collection, price each

	Piece	EUR
<input type="checkbox"/> 1. Foam extinguisher capacity 6 l, designed to EN 3, rating 21 A, 233 B 6 units of extinguishing agent	_____	43.90
<input type="checkbox"/> 2. Cooking oil & fat fire extinguisher designed to EN 3 rating A13, B113, F75 4 units of extinguishing agent Suitable for extinguishing burning cooking oil or fat.	_____	76.50
<input type="checkbox"/> 3. CO₂ extinguishers 5 kg capacity, designed to EN 3, rating 89 B are essential for machine distributors with more than 6 kW rating and electrical canteen equipment (e.g. cooker, grill, extractor hood..).	_____	46.10
<input type="checkbox"/> 4. Powder extinguishers 6 kg capacity, designed to EN 3, rating 34 A, 183 B and C are essential if combustible gases are used (e.g. propane, butane..).	_____	46.10

More information about fire extinguishers can be found in Section 4.4.1.12 of the Technical Regulations.

Orders must be received by not later than 14 days before the event, otherwise the price is subject to a 40 % express surcharge.

Extinguishers are delivered from 8:30 onwards on the first day of the event and must be signed for. They are collected at the end of the event on the last opening day.

VAT ID number of exhibitor:

□ □

An extra charge of EUR 10 is made if repeat delivery is necessary. EUR 150 is charged for replacement/filling. Further injury to persons and damage to stands, exhibits, etc. are not covered by this charge and must be settled with the party suffering the damage. The proper use of the extinguisher in the event of a fire is included in the price.

The exhibitor is responsible for rented fire extinguishers from the time of handover on the stand until collection by the ServicePartner (up to maximum 1 hour after the official end of the event on the last opening day).

Payment must be made before the event; if this is no longer possible due to a late order, the ServicePartner will collect payment during the exhibition. The following credit cards are accepted: MasterCard, American Express, Visa.

Special Conditions for Services provided by Messebau Wörnlein GmbH

1. This order form also acts as the contract to supply goods, unless cancelled by us.
2. Unless otherwise stated, the rental charge is calculated for the duration of the event.
3. Unless otherwise stated, all items listed are available for rental only.
4. Exhibitors wishing to cancel orders must notify the ServicePartner in writing at least 10 days before the start of event, otherwise the full rental charge will be invoiced.
5. Payment is due in full immediately on receipt of the invoice. Foreign exhibitors not settling invoices in cash will be debited with any bank transfer charges incurred.
6. **All prices are subject to the addition of VAT at the statutory rate.**
7. The place of fulfillment and jurisdiction for both parties, including debt collection proceedings, is Nürnberg.

* If necessary, NürnbergMesse is entitled to have the service ordered provided by another ServicePartner. In this case, the customer will be notified of the other ServicePartner in good time.

With our authorized signature below, we acknowledge acceptance of all items of the General and Special Terms of Business of NürnbergMesse and the General Terms of Business and the Special Conditions for Services of the ServicePartner.

Place and date

Company stamp and authorized signature

Nuremberg, Germany
14-16.3.2017



embeddedworld2017

Exhibition & Conference
... it's a smarter world

Return to
NürnbergMesse GmbH
MesseService
Messezentrum
90471 Nürnberg
Tel +49 (0) 9 11. 86 06-80 00
Fax +49 (0) 9 11. 86 06-80 01
messe-service@nuernbergmesse.de

Contractor *
Lehrieder Catering-Party-Service
GmbH & Co. KG
Messezentrum 1, 90471 Nürnberg
Tel +49 (0) 9 11. 86 06-61 14
Fax +49 (0) 9 11. 86 06-61 15
info@lehrieder.de
www.lehrieder.de

Return deadline
14.12.2016

Hall/Stand

Company

Street

Postcode, Town, Country

Tel

Fax

E-mail

Person to contact

Tel

Fax

Invoice address (only if different)

Dear Fair Client,

we would like to help you make your fair presentation a success from the culinary aspect, too. As a NürnbergMesse ServicePartner, we offer you a constantly high standard of quality and service. Give your guests nothing but the best specialties – prepared absolutely fresh by us on the spot.

The following offers (stand catering) represent only an extract from our extensive culinary program. Visit our homepage on the Internet at www.lehrieder.de for more information about our complete range.

We are naturally pleased to prepare an individual catering concept for your fair presentation and make you a personal offer for planning and organizing other events at the fair.

For a personal consultation we are always available under the following service number: Tel +49 (0) 9 11. 86 06-61 14 or -61 17.

We would like to thank you for choosing us for your catering services and wish you and your business partners a pleasant and successful time at NürnbergMesse.

Your Lehrieder Exhibition Team

Orders should be made in writing at least 1 week before the start of the exhibition.

Orders after the deadline of 2 weeks before start of the fair will be charged with EUR 25!

Order (see last page for delivery and service conditions)

Article	EUR/Qty.
---------	----------



½ topped round rolls or grain rolls

Minimum order: 10 items per sort

Round rolls or grain rolls classic garnished with egg, cucumber, tomato	Round	Grain
● Cooked ham	_____	_____
● Selected sausage specialties	_____	_____

* If necessary, NürnbergMesse is entitled to have the service ordered provided by another ServicePartner. In this case, the customer will be notified of the other ServicePartner in good time.
With our authorized signature below, we acknowledge acceptance of all items of the General and Special Terms of Business of NürnbergMesse and the General Terms of Business and the Special Conditions for Services of the ServicePartner.

Place and date

VAT ID number of exhibitor:

<input type="text"/>	<input type="text"/>	<input type="text"/>	<input type="text"/>	<input type="text"/>	<input type="text"/>	<input type="text"/>	<input type="text"/>	<input type="text"/>	<input type="text"/>	<input type="text"/>	<input type="text"/>	<input type="text"/>	<input type="text"/>	<input type="text"/>	<input type="text"/>	<input type="text"/>	<input type="text"/>	<input type="text"/>	<input type="text"/>
----------------------	----------------------	----------------------	----------------------	----------------------	----------------------	----------------------	----------------------	----------------------	----------------------	----------------------	----------------------	----------------------	----------------------	----------------------	----------------------	----------------------	----------------------	----------------------	----------------------

Article	EUR/Qty.	
	Round	Grain
● Emmental cheese	2.60	2.90
● Salami	_____	_____
● Smoked ham	_____	_____
Round rolls or grain rolls exclusive garnished with egg, cucumber, tomato	Round 2.70	Grain 3.10
● Smoked salmon	_____	_____
● Brie cheese	_____	_____
● Roast beef	_____	_____

Mini bread sticks

Minimum order: 10 items per sort

● Mini bread stick with Emmental cheese	3.10	_____
● Mini bread stick with uncooked ham	_____	_____
● Mini bread stick with salami	_____	_____
● Mini bread stick with Brie	_____	_____

Delicious ciabatta rolls (whole roll)

Minimum order: 10 items per sort

Ciabatta rolls mixed garnished with egg, cucumber, tomato	3.70	_____
● Italian country ham	_____	_____
● Salami – milano	_____	_____
● Tomato & Mozzarella	_____	_____

Sandwiches

Minimum order: 10 items per sort

American sandwiches	4.50	_____
● Cooked ham, cucumber, tomato, sliced egg and iceberg lettuce	_____	_____
● Cheese, cucumber, tomato, mayonnaise sliced egg and iceberg lettuce	_____	_____



Delicatessen canapés

Minimum order: 10 items per sort

Franconian canapés	2.70	_____
● Cold sausage & onions	_____	_____
● Smoked neck of pork with prune	_____	_____
● Hand-made cheese & radishes	_____	_____
● Roast neck of pork	_____	_____

Company stamp and authorized signature

Order/Lehrieder (continued; see last page for delivery and service conditions)

All prices plus VAT at the statutory rate.

Article	EUR	Qty.
Minimum order: 10 items per sort		
Classic canapés	2.30	
● Spread cheese "Bresso" with herbs		_____
● Pepper curd cheese		_____
● Cream cheese		_____
International canapés	3.10	
● Smoked salmon with lemon		_____
● Parma ham with honeydew melon		_____
● Rare roast beef and pickles		_____
● Salami Milano with dried tomatoes		_____
● Brie cheese & grapes		_____



Fingerfood

Order as package containing 10 pieces per sort
Articles delivered cold, on a platter

Italian specialties	3.00	
● Honeydew melon with Parma ham		_____
● Tomato & Mozzarella skewers		_____
● Diced veal with tuna fish sauce		_____
● Antipasti with stuffed olives		_____
● Antipasti with stuffed mushrooms		_____
Asian specialties	3.10	
● Shrimps in batter with mango dip		_____
● Saté spears with peanut sauce		_____
● Samosa with sweet & sour sauce		_____
Vegetarian specialties	2.70	
● Spring rolls with vegetable filling		_____
● Artichoke hearts with herbal curd cheese filling		_____
International specialties		
Minimum order: 10 pieces per sort		
Mini puff pastries (cold, handmade), with savoury filling	3.00	
● Tomato & cheese		_____
● Cooked ham & mushroom		_____
● Salmon & spinach		_____
Fingerfood	Price per piece	
Mini sandwich on a skewer	1.60	
● Ham/cheese		_____
● Salami/cheese		_____
● Cheese/cheese		_____
● Mini-panizza		_____

Soups, delivered in insulated soup pot with ladle

Hot Snacks	Price per person with bread	
Minimum order 10 portions	5.35	_____
● Fruity tomato soup with basil and croutons		_____
● Hearty goulash soup		_____
● "Knoblauchsland" potato soup with sliced fried sausage and croutons		_____

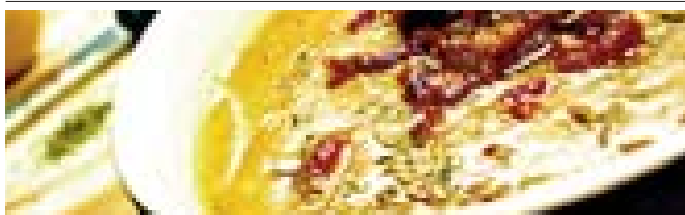

With our authorized signature below, we acknowledge acceptance of all items of the General and Special Terms of Business of NürnbergMesse and the General Terms of Business and the Special Conditions for Services of the ServicePartner.

Place and date

Article	EUR	Qty.
Snacks		
Hot snacks		
Minimum order 10 portions per item		
● 3 Nuremberg fried sausages with sauerkraut, bread and mustard	3.90	_____
● Two Viennese boiled sausages (turkey) with mustard and bread roll	3.50	_____
● 1 Meat rissole with potato & cucumber salad	3.80	_____
● Two Munich boiled sausages with sweet mustard and pretzel	3.80	_____
● Fresh-baked meat loaf	200 g 3.10	_____
● Chili con carne with baguette	5.50	_____
We can also supply the necessary kitchen utensils for keeping food hot etc.	price on request	

Fresh-baked products

Minimum order 10 pieces per item		
● Crispy roll	0.80	_____
● Bread stick with salt	1.10	_____
● Pretzel with salt	1.15	_____
● Pretzel buttered	1.60	_____
● French baguette	3.60	_____
● Ciabatta	3.80	_____
● Stone-baked baguette	3.80	_____
● Stone-baked baguette with olives	4.40	_____

Single items

● Franconian farm bread, sliced 1 kg	5.00	_____
● Mixed bread basket with 3 sorts of rolls and bread specialties (for 10 persons)	18.90	_____

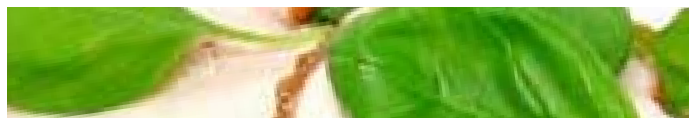

Delicatessen & salads for 10 persons

Delicatessen platters of fresh gourmet food

Each deliciously garnished on a platter

Spanish platters: Olives, Manchego, Serano ham, grilled pepper, Parma ham and Parmesan cheese	44.00	_____
---	-------	-------

Franconian snack: smoked Nuremberg fried sausage, home-made liver sausage, smoked pork, cold sausage, uncooked ham, horseradish, mustard, gherkins and farm bread	41.50	_____
---	-------	-------

Delicatessen platters to special order can be provided on request.

Salads

in salad bowl for approx. 10 persons

Franconian potato salad with cucumbers and onions	12.00	_____
Homemade pasta salad	12.00	_____
Tomatoes with Mozzarella and fresh basil	21.85	_____
Mixed Mediterranean antipasti	24.50	_____

Salat to Go (minimum order 10 pieces per item) Price per portion

Green salad with ham, cheese, egg & tuna and...	4.50	_____
● Oil & vinegar dressing		_____
● Yogurt & herb dressing		_____

Cheese treats

Selection of Bavarian cheeses	1 kg 23.55	_____
Cheese "hedgehog": Emmental and Gouda cheese on sticks with olives, grapes and cherry tomatoes	piece 45.80	_____
Selection of French cheeses made from untreated milk, with grapes, fig mustard, nut bread and butter	20 persons 78.60	_____

Fitness package

Fair fitness package

Minimum order: 10 pieces

Vegetable sticks		
"4 colors - 4 flavors": aioli, curry, herbs and cocktail dip with vegetables of the season	portion 3.70	_____
Fruit salad with fruits of the season	portion 4.00	_____

Company stamp and authorized signature

Order/Lehrieder (continued; see last page for delivery and service conditions)

All prices plus VAT at the statutory rate.

Article	Unit	EUR	Qty.
Fruits			
Basket of fruits 3 kg (fruit of the season)	portion	40.55	_____

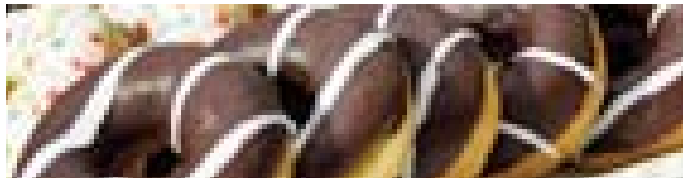

Cakes and nibbles

Sweet things from our patisserie

Minimum order 10 pieces per item

Fruit cake, cheese cake			
Apple cake, according to season	piece	2.70	_____

Mini cakes and pastry

Minimum order 10 pieces per item

Mini muffin mixed	piece	0.90	_____
Mini donut mixed	piece	0.90	_____
Mini chocolate croissant	piece	1.35	_____
Butter croissant	piece	1.65	_____
Brownie cakes premium	piece	1.70	_____
Mini pastries mixed	piece	1.35	_____
Mixed pastries	piece	2.30	_____

Cookies, nibbles, and sweet things

CELEBRATIONS® box of chocolate bars & chocolates		7.80	_____
Selection of salted biscuits	1 kg	10.70	_____
Tea time biscuits	1 kg	20.70	_____
Chips	25 gr	2.00	_____
Peanuts	1 kg	11.50	_____
Nic Nacs	1 kg	19.50	_____

Minis/mixed, from Mars, Balisto, Bounty, Snickers or Twix	150 pieces	50.00	_____
---	------------	-------	-------

Dessert

Minimum order 10 pieces per item	piece	4.10	_____
Panna cotta			_____
Red berry pudding with vanilla sauce			_____



Soft drinks, coffee & tea

Soft drinks

Minimum order 1 container

Bottle opener	piece	2.50	_____
Orange juice	6 x 1 l	18.10	_____
Apple juice	6 x 1 l	18.10	_____
Multivitamin juice	6 x 1 l	24.50	_____
Apollinaris sparkling water	12 x 0.75 l	24.80	_____
Vio natural water	12 x 0.75 l	24.80	_____

Article	Unit	EUR	Qty.
Coca Cola	12 x 1 l 24 x 0.25 l	22.40 24.00	_____
Fanta	12 x 1 l 24 x 0.25 l	22.40 24.00	_____
Sprite	12 x 1 l 24 x 0.25 l	22.40 24.00	_____
Vio apple juice & mineral water	12 x 1 l 24 x 0.25 l	22.40 24.00	_____

Coffee & tea

Ronnefeldt tea, different varieties	25 bags	4.15	_____
Tea in a thermos pot	pot	9.90	_____
Coffee in a thermos pot including milk & sugar (Lavazza)	pot	10.90	_____
Ground coffee (Lavazza)	500 g	12.25	_____
Coffee beans (Lavazza)	1 kg	22.55	_____
Espresso beans (Lavazza)	1 kg	25.00	_____



Beer, wine & sparkling wine

Beer

Tucher Pils 30 l	1 keg	110.80	_____
Tucher Yeast Wheat 30 l	1 keg	125.20	_____
Jever Pils 30 l keg	1 keg	125.20	_____
Tucher Pils "Cool Keg" 20 l (self-cooling beer keg, not an inline cooler and no carbonation necessary)	1 keg	98.00	_____
Tucher Yeast Wheat "Cool Keg" 20 l (self-cooling beer keg, not an inline cooler and no carbonation necessary)	1 keg	104.30	_____
Tucher Pils	24 x 0.33 l	29.30	_____
Jever Pils	24 x 0.33 l	29.30	_____
Jever Fun alcohol-free	24 x 0.33 l	29.80	_____
Tucher Yeast Wheat	20 x 0.5 l	29.30	_____

Wine & sparkling on request!

Minimum order 1 carton/6 bottles

International wines on request			
Prosecco Frizzante "Maschio dei Cavalieri" DOC Treviso Spumante Extra Dry, grape variety 100 % Glera. Fine perlage – fresh and fruity	6 x 0.75 l	90.80	_____
Castell-Castell QbA Bordeaux bottle. Own label (white wine) CC Silvaner QbA. Exciting Silvaner with refreshing balance of sweetness and acidity	6 x 0.75 l	88.80	_____
Castell-Castell 1224 QbA (red wine) Full-bodied, fruity red wine cuvée from Domina, Dornfelder, Acolon and Regent grape varieties with soft tannin structure	6 x 0.75 l	95.30	_____

With our authorized signature below, we acknowledge acceptance of all items of the General and Special Terms of Business of NürnbergMesse and the General Terms of Business and the Special Conditions for Services of the ServicePartner.

Place and date

Company stamp and authorized signature

Order/Lehrieder (continued)
All prices plus VAT at the statutory rate.

Article	Unit	EUR	Qty.
Catering equipment			
● Please note that container sizes cannot be changed			
● Minimum order 10 pieces per item for glasses			
Uniglass		36 pieces	
Sparkling wine glass		49 pieces	
Beer glass in carton	24 pieces or	40 pieces	
Wheat beer/latte macchiato/wine glass		25 pieces	
Champagne glass		36 pieces	
● Minimum order 10 pieces per item for crockery and cutlery			

Cutlery & crockery			
Stirrers for cups	piece	0.20	_____
Cutlery (knife, fork, spoon etc.)	day/piece	0.35	_____
Plates, 20 cm or 25 cm	day/piece	0.35	_____
Uniglass, sparkling wine glass, beer glass or wheat beer glass	day/piece	0.35	_____
"To go" beaker for coffee	piece	0.40	_____
"To go" beaker for soft drinks	piece	0.40	_____
Coffee cup, saucer and spoon	day/piece	1.05	_____
Espresso cup incl. saucer and spoon	day/piece	1.05	_____
Latte macchiato glass with accessories	day/piece	1.05	_____

Accessories			
Waste bags 120 l (roll of 25 bags) without disposal	1 roll	6.80	_____
Waste bags 32 l (roll of 50 bags) without disposal	1 roll	7.60	_____
Paper serviettes, pack of 250	pack	21.60	_____
Milk portions, pack of 240	pack	23.90	_____
Sugar portions, pack of 2,000	pack	45.85	_____
"All you need" stand package: 2 sponge cloths, 2 kitchen towels, 2 paper rolls, 1 washing up brush, 1 washing up liquid, 10 small waste bags, 1 small garbage bin	piece	27.40	_____

Tables, stools			
Standing table with stretch cover	per day/piece	32.60	_____
Table cloth, various colors	per day/piece	7.60	_____
Bar stool, Z-shape, chrome, black upholstery	per day/piece	17.90	_____

Equipment & accessories			
Coffee box, comprising: 1 Bonamat coffee machine incl. filters, 2 thermos pots	single charge	38.50	_____
Coffee box, comprising: 1 Bonamat coffee machine incl. filters, 2 thermos pots, 10 cups/saucers, coffee spoons, 500 g of coffee, 100 portions of sugar & milk	single charge	66.70	_____
Coffeemaker for coffee/espresso/hot water	day/piece	185.00	_____
Electric water kettle	piece	16.50	_____
Inline cooling system for beer 2-line	for 3 days	500.00	_____
Carbonic acid bottle	piece	41.00	_____
Sausage boiler with tongs	piece	33.00	_____
Insulated soup pot with ladle	piece	33.00	_____

Services			
● Please note that we assume and charge for a minimum working time of four hours a day in each case. Setup and dismantling times count as working times and are invoiced as such.			
Service staff	per hour	32.50	_____
Cook	per hour	39.00	_____
Barkeeper/bar manager	per hour	41.50	_____
Technician for assembly/dismantling	per hour	33.40	_____

With our authorized signature below, we acknowledge acceptance of all items of the General and Special Terms of Business of NürnbergMesse and the General Terms of Business and the Special Conditions for Services of the ServicePartner.



All-inclusive stand parties

for a pleasant get-together with your customers on the evening of the exhibition

All our offers include:

- Our friendly service staff for looking after your guests
- Standing tables, crockery, glasses, small plates and serviettes
- Please note that we have to charge extra for a technician for setup and dismantling.

The exact number of guests is arranged with you in advance. We allow 3 hours for the duration of each event. For events planned for longer than 3 hours we charge EUR 25 per guest for each additional hour.

For more information please contact our service number Tel +49 (0) 9 11. 86 06-61 14 at any time.

A variety of other suggestions can be found at www.lehrieder.de

Bavarian stand party (warm snacks)	50 or more persons each	40.70	_____
set up as buffet	100 or more persons each	37.80	_____
● Home-made meat balls with potato fritters and fresh vegetables	150 or more persons each	35.70	_____
● Fried Nuremberg sausages with sauerkraut			
● Fresh-baked meat loaf with mixed home-made potato salad			
● Roast pork with mini potato dumpling			
● Available on the standing tables: Dripping, pots of herb quark, crusty bread and pretzels			
● Plus "all you can drink": draught beer, wheat beer, mineral water, orange juice and apple juice			

Fingerfood stand party (cold snacks)	50 or more persons each	36.60	_____
Fine delicacies, arranged on serving etageres on the standing tables	100 or more persons each	33.50	_____
(5 pieces per person):	150 or more persons each	32.50	_____
● Honeydew melon with parma ham			
● Mozzarella & cherry tomatoes on skewers with basil			
● Grilled vegetables on skewers with garlic mayonnaise			
● Mild smoked salmon on a lettuce leaf, with horseradish cream and dill bouquet			
● Marinated shrimps with cocktail sauce and sliced toast			
● Chicken breast roulade & mango in a sesame crust			
● Sliced saddle of veal with choice of dips			
● Artichoke hearts with herb quark filling			
● Plus "all you can drink": Italian white wine, draught beer, mineral water, orange juice, apple juice and sparkling wine			

TAPAS stand party (cold snacks)	50 or more persons each	36.00	_____
set up as buffet	100 or more persons each	35.00	_____
● Stuffed olives with chorizo	150 or more persons each	34.00	_____
● Stuffed eggplant with dried tomatoes			
● Chili-saffron shrimp on polenta mousse			
● Marinated artichokes with feta			
● Diced pork tenderloin with garlic-almond dip			
● Iberico ham with melon juice			
● Small meat skewers with herbs & tomato marmalade			
● Mango-orange chutney with grilled sea bass fillet			
● Grilled octopus in garlic, lemon & herbs			
● Machego with apricot mustard & herbs			
● "All you can drink": Spanish white wine, draft beer, mineral water, orange juice, apple juice, sparkling wine			

Place and date _____

Company stamp and authorized signature _____

Delivery and service conditions of Lehrieder Catering-Party-Service GmbH & Co. KG (Catering, stand catering)

- **Important: Your order is not deemed to have been received until you have an order confirmation from us.**
 - For logistics reasons, the delivery of the first order for drinks is made during the afternoon of the day before the exhibition starts. A fixed transport charge of EUR 10 net per delivery is agreed.
 - Follow-up deliveries are possible.
 - Drinks are delivered on a sale or return basis.
 - The minimum order is 10 of each item for food and 1 crate for drinks.
 - Only full crates can be taken back. Incomplete crates, single bottles or kegs are not taken back. We charge a return fee of EUR 5 for original crates.
 - Returning packaged food items like coffee, sugar and milk is not possible.
 - A charge will be made for empties not returned.
 - Breakages and losses are charged at cost price.
 - Food made with certified organic ingredients must be ordered 2 weeks in advance.
 - Stand catering is restricted to the NürnbergMesse exhibition site. Deliveries cannot be made to the restaurants or congress rooms in the exhibition center. We will be pleased to make you a separate offer for catering services in the conference rooms of the exhibition.
 - Food is charged according to the quantity ordered and can only be cancelled up to 1 week before the exhibition starts.
 - Complaints, especially about food, must be notified to the person responsible for stand catering on the same day. Later complaints cannot be accepted as these can no longer be checked.
 - Rental equipment must be sorted and made ready for collection at the end of the exhibition by the customer, otherwise we must charge the cost of personnel for sorting.
 - Please notify us of your correct invoice address before the start of the exhibition. We charge a processing fee of EUR 25 for issuing new invoices due to incorrect invoice data.
 - A cancellation charge of EUR 20 is payable for late cancellations.
 - Payment is made for each delivery.
 - All prices are subject to VAT at the statutory rate.
 - After the trade fair is over we deduct the invoice amount from your credit card and send you the invoices by post.
 - For companies with registered offices outside Germany, orders must be paid by credit card in advance on receipt of order confirmation/invoice. If it is not possible to deduct the invoice amount from the specified credit card a week before the start of the trade fair at the latest, the order will be cancelled.
- Please state your credit card details below:
- Issuer: MasterCard VISA
- Card no.: _____ / _____ / _____
- Card verification no.: (The last 3 digits on the back)
- Valid until: _____
- Card holder: _____
- We authorize Lehrieder Catering-Party-Service GmbH & Co. KG to charge the invoice amount to the above-mentioned credit card.
 - The place of jurisdiction and fulfillment for both parties, including debt collection proceedings, is Nürnberg.

Delivery times

Your order or cancellation instructions must be received by phone or fax up to 14:00 the day before. Any changes after 14:00 cannot be accepted.

Tel +49 (0) 9 11. 86 06-61 14, Fax +49 (0) 9 11. 86 06-61 15

- **First order for drinks:**
For logistics reasons at large exhibitions, the delivery of the first order for drinks is made during the afternoon of the day before the exhibition starts. Continuous food order

Delivery time: _____

- **Food order for daily delivery for the duration of the exhibition.**
Food order for the first day of the exhibition:

Delivery time: _____

First delivery	Time
Delivery date	Time
Delivery date	Time
Delivery date	Time

ServicePartner:

Lehrieder Catering-Party-Service GmbH & Co. KG
Messezentrum 1
90471 Nürnberg
Tel +49 (0) 9 11. 86 06-61 14
Fax +49 (0) 9 11. 86 06-61 15
info@lehrieder.de
www.lehrieder.de

With our authorized signature below, we acknowledge acceptance of all items of the General and Special Terms of Business of NürnbergMesse and the General Terms of Business and the Special Conditions for Services of the ServicePartner.

Place and date

Company stamp and authorized signature

Nuremberg, Germany
14–16.3.2017



embeddedworld2017

Exhibition & Conference
... it's a smarter world

Return to
NürnbergMesse GmbH
MesseService
Messezentrum
90471 Nürnberg
Tel +49 (0) 9 11. 86 06-80 00
Fax +49 (0) 9 11. 86 06-80 01
messeservice@nuernbergmesse.de

Company _____

Street _____

Postcode, Town, Country _____

Tel _____

Fax _____

E-mail _____

Return deadline	Hall/Stand
14.12.2016	
Person to contact _____	
Tel _____	
Fax _____	
Invoice address (only if different) _____	

Order

E-Max hot/cold

The E-Max hot/cold is sturdy, easy to clean and easy to use thanks to the large buttons.



- Provides **hot** or **cold** water on demand
- Integrated cup dispenser and removable drip tray
- Flexible – can be installed anywhere with a power point in the vicinity
- Dimensions (H including bottle/W/D): 139/33/32.5 cm
- Capacity: 1.8 litre tank for cold water (temperature adjustable)
- 1.2 litre tank for hot water
- Suitable for 18.9 litre bottles
- Weight: 17.2 kg
- Power consumption: 230 V, 1150 Watt

F-Max cold

With its elegant, timeless design, the F-Max is a stylish enhancement to any ambience.



- Provides **cold** or **ambient temperature** water on demand
- Integrated cup dispenser and removable drip tray
- Flexible – can be installed anywhere with a power point in the vicinity
- Dimensions (H including bottle/W/D): 146/36/37.5 cm
- Capacity: 2.5 litre tank for cold water
- Suitable for 18.9 litre bottles
- Weight: 20 kg
- Power consumption: 230 V, 1150 Watt

F-Max hot/cold

With its elegant, timeless design, the F-Max is a stylish enhancement to any ambience.



- Choice of **hot**, **cold**, or **ambient temperature** water
- Integrated cup dispenser and removable drip tray
- Flexible – can be installed anywhere with a power point in the vicinity
- Dimensions (H incl. bottle/W/D): 146/36/37.5 cm
- Capacity: 2.5 litre tank for cold water
- 1.2 litre tank for hot water
- Suitable for 18.9 litre bottles
- Weight: 20 kg
- Power consumption: 230 V, 1150 Watt

VAT ID number of exhibitor:

<input type="text"/>	<input type="text"/>	<input type="text"/>	<input type="text"/>	<input type="text"/>	<input type="text"/>	<input type="text"/>	<input type="text"/>	<input type="text"/>	<input type="text"/>	<input type="text"/>	<input type="text"/>	<input type="text"/>	<input type="text"/>	<input type="text"/>	<input type="text"/>	<input type="text"/>	<input type="text"/>	<input type="text"/>	<input type="text"/>
----------------------	----------------------	----------------------	----------------------	----------------------	----------------------	----------------------	----------------------	----------------------	----------------------	----------------------	----------------------	----------------------	----------------------	----------------------	----------------------	----------------------	----------------------	----------------------	----------------------

Binding order

- | | |
|--|----------------|
| <input type="checkbox"/> Water cooler E-Max hot/cold
Price each EUR 249 for the duration of the event | Quantity _____ |
| <input type="checkbox"/> Water cooler F-Max cold
Price each EUR 299 for the duration of the event | Quantity _____ |
| <input type="checkbox"/> Water cooler F-Max Design hot/cold
Price each EUR 341 for the duration of the event | Quantity _____ |

The specified prices include the following:

- **Fixed installation charge** (installation and removal of water cooler)
- **Rental charge** water cooler
- **3 water bottles** (Aquatrade drinking water – 18.9 litres each)
- **200 cups**

Please note:

NürnbergMesse accepts no liability for any damage during the rental period. In the event of theft of the equipment during the rental period, the listed selling price will be charged. We recommend that you take out exhibition insurance, or better still, engage a stand security guard. Any bottles not returned will be charged at EUR 10 per bottle. The cooler will be installed by no later than 8:30 on the first day of the exhibition and will be removed on the last day immediately after the event closes.

All prices are quoted exclusive of statutory sales tax/VAT. By signing below you accept all stated terms and conditions.

Please fill in for payment by credit card:

Issuer : MasterCard VISA American Express

Card no.: : _____ / _____ / _____

Card verification no.: (The last 3 digits next to the signature on the back of the card or for AMEX 4 digits on the front)

Expiry date : _____

Holder of card: _____

We authorize NürnbergMesse GmbH to charge the invoice amount to the above-mentioned credit card.

Signature: _____

Place and date

Company stamp and authorized signature

Rental crockery, dishwashing service

S3.18

Nuremberg, Germany
14-16.3.2017



embeddedworld2017

Exhibition&Conference
... it's a smarter world

Return to
NürnbergMesse GmbH
MesseService
Messezentrum
90471 Nürnberg
Tel +49 (0) 9 11. 86 06-80 00
Fax +49 (0) 9 11. 86 06-80 01
messe-service@nuernbergmesse.de

Contractor *
Bilfinger ProfiMiet München GmbH · NL Fürth
Dieselstraße 22
90765 Fürth
Tel +49 (0) 9 11. 99 94 42-0
Fax +49 (0) 9 11. 99 94 42-1 11
fuerth.profimiet@bilfinger.com
www.profimiet.bilfinger.com

Return deadline
14.12.2016

Hall/Stand

Company _____
Street _____
Postcode, Town, Country _____
Tel _____
Fax _____
E-mail _____

Person to contact at the exhibition _____

Mobile phone no. _____

Invoice address (only if different) _____

Order (Special Conditions for Services overleaf)

Delivery date: _____ **Delivery time:** from _____ to _____

Note
Bilfinger ProfiMiet is pleased to deliver the equipment a day before the exhibition starts **without** a surcharge (rental).

- Please complete form in block capitals -

Rental and washing of glasses and crockery

Articles are delivered to the stand at the collected at the end on payment of a charge of EUR 20.

We wish to use the daily exchange service (delivery/collection EUR 20).

The rental of articles is subject to payment of a fixed deposit of EUR 50.

Please fill in for payment by credit card:

Issuer : MasterCard VISA EC

Card no.: _____ / _____ / _____

Card verification no.: _____ (The last 3 digits next to the signature on the back of the card or for AMEX 4 digits on the front)

Expiry date : _____

Holder of card: _____

We authorize Bilfinger ProfiMiet München GmbH · NL Fürth to debit the invoice amount from the above-mentioned credit card.

Signature: _____

VAT ID number of exhibitor:

1. Rental crockery

Illustration	Designation		EUR	Quantity
	Set 1 30 dinner plates, 30 knives, 30 forks	per day	22.50	
	Set 2 30 cake/dessert plates, 30 cake forks	per day	15.00	
	Set 3 30 coffee cups, 30 saucers, 30 coffee spoons	per day	17.50	
	Set 4 30 demitasse cups, 30 saucers, 30 demitasse spoons	per day	15.00	
	Dinner plate 30 pieces	per day	7.50	
	Soup plate 30 pieces	per day	7.50	
	Soup cup and saucer 30 pieces	per day	10.00	
	Cake/dessert plate 30 pieces	per day	7.50	
	Coffee cup and saucer 30 pieces	per day	13.50	
	Demitasse cup and saucer 30 pieces	per day	13.50	

Orders received later than 14 days before the start of the event will be billed an express surcharge of 25 %, subject to a minimum surcharge of EUR 10 per order.

* If necessary, NürnbergMesse is entitled to have the service ordered provided by another ServicePartner. In this case, the customer will be notified of the other ServicePartner in good time.



With our authorized signature below, we acknowledge acceptance of all items of the General and Special Terms of Business of NürnbergMesse and the General Terms of Business and the Special Conditions for Services of the ServicePartner.

Place and date

Company stamp and authorized signature

Order (continued)



2. Rental cutlery

Illustration	Designation		EUR	Quantity
	Knives 30 pieces	per day	8.00	
	Forks 30 pieces	per day	8.00	
	Soup spoon 30 pieces	per day	8.00	
	Coffee spoon 30 pieces	per day	8.00	
	Cake fork 30 pieces	per day	8.00	
	Demitasse spoon 30 pieces	per day	8.00	
	Latte macchiato spoon 30 pieces	per day	8.00	

3. Rental glasses

	Sparkling wine glasses 0.17 l, 24 pieces	per day	8.00	
	White wine glasses 0.225 l, 24 pieces	per day	8.00	
	Red wine glasses 0.3 l, 24 pieces	per day	8.00	
	Water glasses 0.25 l, 36 pieces	per day	11.00	
	Beer glasses 0.25 l, 24 pieces	per day	8.00	
	Wheat beer glasses 0.3 l, plain, 24 pieces	per day	8.00	
	Wheat beer glasses 0.5 l, plain, 24 pieces	per day	8.00	
	Martini glasses 12 pieces	per day	3.70	
	Caipirinha glasses/ latte macchiato glasses 35 cl, 24 pieces	per day	7.50	
	Tasting glasses 0.215 l, 40 pieces	per day	12.00	

4. My Drap disposable serviettes

Illustration	Designation	PU	EUR	Quantity
	Disposable cotton serviette 11 cm x 11 cm various colors	50 pieces	0.15*)	
	Disposable cotton serviette 20 cm x 20 cm various colors	25 pieces	0.30*)	
	Disposable cotton serviette 40 cm x 40 cm various colors	12 pieces	0.50*)	

*) The prices stated are per piece and **not** per packing unit (PU).

5. Miscellaneous

Illustration	Designation		EUR	Quantity
	Ice cubes, 2 kg bag		4.00	
	Crushed ice, 2 kg bag		4.00	
	Sparkling wine cooler, Chrome	per day	1.50	
	Champagner Bowl	per day	2.50	
	Thermos flask stainless steel, 1.5 l	per day	1.50	
	Cuspidor, offer for sale		11.00	
	1 x fully automatic coffee machine Jura XS 95 or X9, 30 coffee & demitasse cups, 30 latte macchiato glasses, 90 saucers, 30 coffee-demitasse and latte macchiato spoons	per day	150.00	

Other articles on request.

Example photos. The rented material may differ from the products shown here.

**Special Conditions for Services provided
by Bilfinger ProfiMiet München GmbH · NL Fürth**

- All prices plus VAT at the statutory rate.
- The rented goods are not insured.
- The cost of missing or defective parts and damage due to force majeure is charged to the exhibitor.
- Breakages and losses are charged as follows:
 - per glass per piece EUR 2.50
 - for crockery per piece EUR 5.50
 - for cutlery per piece EUR 3.50
 - per carrier box per piece EUR 50.00
- The price for losses may vary for exclusive china and glass.
- The place of jurisdiction and fulfillment for both parties, including debt recovery proceedings, is Nürnberg.
- The goods are due for payment in full in cash immediately on handover or in advance by bank transfer.
- The rented goods are collected on the last day after the end of the exhibition.

NürnbergMesse ServicePartner:

Bilfinger ProfiMiet München GmbH · NL Fürth
Dieselstraße 22, 90765 Fürth

Tel +49 (0) 9 11. 99 94 42-0

Fax +49 (0) 9 11. 99 94 42-1 11

fuerth.profimiet@bilfinger.com, www.profimiet.bilfinger.com



Orders received later than 14 days before the start of the event will be billed an express surcharge of 25 %, subject to a minimum surcharge of EUR 10 per order.

With our authorized signature below, we acknowledge acceptance of all items of the General and Special Terms of Business of NürnbergMesse and the General Terms of Business and the Special Conditions for Services of the ServicePartner.

Place and date _____

Company stamp and authorized signature _____

Nuremberg, Germany
14–16.3.2017



embeddedworld2017

Exhibition&Conference
... it's a smarter world

Return to
NürnbergMesse GmbH
MesseService
Messezentrum
90471 Nürnberg
Tel +49 (0) 9 11. 86 06-80 00
Fax +49 (0) 9 11. 86 06-80 01
messeservice@nuernbergmesse.de

Contractor *
Halls 3–7A
Kiefer GmbH

Halls 1, 2, 8–12
dias
Gebäudemanagement GmbH

Company _____

Street _____

Postcode, Town, Country _____

Tel _____

Fax _____

E-mail _____

Return deadline
14.12.2016

Hall/Stand

Person to contact _____

Tel _____

Fax _____

Invoice address (only if different) _____

Order

Order no.: (only if required by your company) _____

General cleaning of exhibition halls is arranged by the organizers. Exhibitors are responsible for arranging cleaning of their own stands.

Floor covering: (please indicate) carpet hard covering

Please state stand area: _____ m² (based on registered gross stand space)
We order as follows:

Basic stand cleaning starts after 19:00

Only for last day of assembly!

– **Once-only cleaning** of tables and chairs, emptying waste paper baskets, damp wiping floor coverings, vacuum cleaning carpets, including removal and disposal of carpet sheet.

(Please order glass and wall cleaning separately!)

Charged per m² of stand area

@ **EUR 2.10** plus VAT at the statutory rate.

Glass, special and wall cleaning starts after 19:00

– Cleaning other furniture, e.g. leaflet stands, glass showcases, doors, partition walls, other horizontal surfaces.

Height up to: _____ meters

per hour **EUR 28.50** plus VAT at the statutory rate.

on last day of assembly only daily

Daily cleaning of stand starts after 19:00

Only bookable from the 1st day of exhibition!

per m² and day **EUR 0.65** plus VAT at the statutory rate

The daily cleaning includes the following services: **damp wiping tables, emptying waste paper baskets, damp wiping hard floor coverings, vacuum cleaning carpets.**

See Info 4, 6.1 – “Waste Management”.

Cleaning of stand after stand party

per m² and day **EUR 1.30** plus VAT at the statutory rate

Date: _____ Time: _____

Date: _____ Time: _____

Date: _____ Time: _____

VAT ID number of invoice addressee:

□□ □□□□□□□□□□□□□□

Important information:

- The exhibitor must ensure that a power supply is available at his stand.
- If the complete stand (not cubicles) can be locked, the key must be deposited with the ServicePartner.
- 75 % surcharge on hourly rate for Sundays and public holidays.
- Complaints: Complaints must be reported to the responsible ServicePartner by 10:00. They are only cleared by remedial action.
- The undersigned confirms possession of the appropriate authorization for placing the order. The recipient of this service is always the exhibitor, who receives a copy of this order from the undersigned.
- The invoice can be sent to a different invoice address. Please note that the final invoice is issued by NürnbergMesse GmbH. A processing fee of EUR 35 per invoice will be charged for changing the address after receipt of the invoice.
- Minimum invoice amount for cleaning stand is **EUR 50** plus VAT at the statutory rate.
- The following credit cards are accepted: MasterCard, American Express, VISA, Diners Club.
- Orders, which are received later than 14 days before the start of the event, will be offset with an express surcharge of 25 %. A 100 % express surcharge is due when the order is received later than 2 days before the start of the event. The minimum surcharge is EUR 50 per order.
- **Please comply with the deadlines for placing orders, as the execution of last-minute orders cannot be guaranteed.**
- **All prices plus VAT at the statutory rate.** Place of fulfillment and jurisdiction including reminder proceedings is Nürnberg for both parties.

ServicePartners:

Halls 3–7A
Kiefer GmbH
Messezentrum Nürnberg
ServicePartnerCenter, 2nd floor
Tel +49 (0) 9 11. 86 06-61 37
Fax +49 (0) 9 11. 9 81 72-30
info@kiefer-cleaning.de
www.kiefer-cleaning.de

Halls 1, 2, 8–12
dias Gebäudemanagement GmbH
Messezentrum Nürnberg
Hall 12, ground floor/NCC West,
1st floor
Tel +49 (0) 9 11. 9 80 80 80
Fax +49 (0) 9 11. 9 80 80 81
nuernberg.messe@dias-service.de
www.dias-service.de

* If necessary, NürnbergMesse is entitled to have the service ordered provided by another ServicePartner. In this case, the customer will be notified of the other ServicePartner in good time.

With our authorized signature below, we acknowledge acceptance of all items of the General and Special Terms of Business of NürnbergMesse and the General Terms of Business and the Special Conditions for Services of the ServicePartner.

Place and date

Company stamp and authorized signature

Nuremberg, Germany
14–16.3.2017



embeddedworld2017

Exhibition & Conference

... it's a smarter world

Return to
NürnbergMesse GmbH
MesseService
Messezentrum
90471 Nürnberg
Tel +49 (0) 9 11. 86 06-80 00
Fax +49 (0) 9 11. 86 06-80 01
messeservice@nuernbergmesse.de

Contractor *
Friedrich Hofmann Betriebsgesellschaft mbH
Messezentrum
90471 Nürnberg
Tel +49 (0) 9 11. 8 12 82 96
Fax +49 (0) 9 11. 8 12 82 97
hofmann-denkt-messe@t-online.de
www.hofmann-denkt.de

Company _____

Street _____

Postcode, Town, Country _____

Tel _____

Fax _____

E-mail _____

Return deadline
14.12.2016

Hall/Stand

Person to contact _____

Tel _____

Fax _____

Invoice address (only if different) _____

Order

Waste disposal service during assembly/dismantling

Every exhibitor is responsible for the disposal of waste produced on his own exhibition stand. Our waste disposal service offers you a variety of services for environment-friendly disposal of waste during the assembly and dismantling phases. The following types of waste disposal always comply with the standards for environmental protection and waste management (c.f. Info 4 – Item 6). If you have appointed an exhibition construction company for your stand, please inform this company of our guidelines.

The invoice addressee is always the official contractual partner (exhibitor) of NürnbergMesse GmbH. Issuing invoices to third parties is only possible after prior approval by the ServicePartner.

Attention! Only persons appointed by NürnbergMesse GmbH are allowed to fill waste containers in the loading yards!

Designation	Unit	EUR	Qty.
Roller container 1 m ³ ** for mixed waste incl. disposal	each	88.95	_____
Disposal of carpets	m ²	1.00	_____
Disposal of plastic sheet	m ²	0.80	_____
Disposal of paper	m ³	23.00	_____
Plastic bags 1.5 m ³	each	27.00	_____
Bulk container 28 m ³ ** excl. disposal	each	105.00	_____
Disposal of wood plus container	t	95.00	_____
Disposal of carpets plus container	t	100.00	_____
Disposal of rubble plus container	t	20.00	_____
Disposal of small amounts of wood:			
Chipboard	m ³	105.00	_____
Stand parts	m ³	30.00	_____
Filling containers	per hour	58.00	_____
Other waste		Price on request	

The invoice can be sent to a different invoice address. A processing fee of EUR 35 per invoice will be charged for changing the address after receipt of the invoice.

Orders can be cancelled free of charge prior to invoicing. A processing fee of EUR 50 per invoice will be charged for cancellation after invoicing. The full rental charge will be payable if the package is not cancelled until the date of delivery.

The minimum invoice amount for the waste disposal service is **EUR 50** plus VAT at the statutory rate.

Assembly delivery date: _____

Dismantling delivery date: _____

** The order for a container includes delivery and collection of the container. Please note when filling the container that it must still be possible to close the container lid completely. If this is not possible, an administrative fee of EUR 50 will be charged for each overfilled container.

* If necessary, NürnbergMesse is entitled to have the service ordered provided by another ServicePartner. In this case, the customer will be notified of the other ServicePartner in good time.

With our authorized signature below, we acknowledge acceptance of all items of the General and Special Terms of Business of NürnbergMesse and the General Terms of Business and the Special Conditions for Services of the ServicePartner.

Place and date

VAT ID number of exhibitor:

□□ □□□□□□□□□□□□□□□□

Waste disposal service during event

Waste bags for the usual kind of waste produced on the stand are distributed to the stands during the event. The full waste bags are to be placed at the edge of the stand by 20:00 in the evening. Information regarding the cost of the waste disposal service can be obtained from the Conditions for Participation in the event. For production waste please order disposal as for assembly/dismantling.

Attention! If waste produced by the exhibitor, his customers and other representatives is still on the site of NürnbergMesse GmbH after the specified assembly/dismantling time without an order having been placed for its disposal, it will be disposed of as mixed waste at a cost of EUR 81.50/m³ plus statutory VAT and a special administrative fee of EUR 50 will also be charged. Waste produced by the exhibitor also includes waste still on his stand after the specified assembly time. The same applies to adhesive tapes or adhesive tape residues not removed from the hall floors by the end of the specified dismantling time.

The ServicePartner guarantees that all waste is disposed of or recycled in accordance with the German Recycling and Waste Management Act. All types of waste will be charged in accordance with the applicable waste regulations and tariffs. All prices plus VAT at the statutory rate. The place of jurisdiction and fulfillment, including for debt recovery proceedings, is Nuremberg for both parties.

Please note that we do not send confirmation of your order.

Please fill in for payment by credit card:

Issuer : MasterCard VISA American Express

Card no. : _____ / _____ / _____

Card verification no.: _____
(The last 3 digits next to the signature on the back of the card or for AMEX 4 digits on the front)

Expiry date : _____

Holder of card: _____

We authorize Friedrich Hofmann Betriebsgesellschaft mbH to debit the invoice amount from the above-mentioned credit card.

Signature: _____

Company stamp and authorized signature

Nuremberg, Germany
14–16.3.2017



embeddedworld2017
Exhibition&Conference
... it's a smarter world

Return to
NürnbergMesse GmbH
MesseService
Messezentrum
90471 Nürnberg
Tel +49 (0) 9 11. 86 06-80 00
Fax +49 (0) 9 11. 86 06-80 01
messeservice@nuernbergmesse.de

Contractor *
Halls 3–7A **
Schenker Deutschland AG
Geschäftsstelle Nürnberg

Halls 1, 2, 8–12 **
Kühne + Nagel
(AG & Co.) KG

Return deadline
14.12.2016

Hall/Stand

Company _____

Street _____

Postcode, Town, Country _____

Tel _____

Fax _____

E-mail _____

Person to contact _____

Tel _____

Fax _____

Invoice address (only if different) _____

Order (Special Conditions for Services overleaf)

1. Delivery to the exhibition stand

Storage of goods in the warehouse: yes no

Delivery to warehouse managed by: _____

Date of delivery to the stand: _____

2. Collection from exhibition stand

Storage of goods in the warehouse: yes no

Collection date: _____ time: _____

Pickup from warehouse managed by: _____

Contact person on stand: _____

3. Personnel and equipment

Please note: Minimum charging unit 1.0 hour.

Assembly: **Forklift truck with driver** **Crane** up to ____ t capacity

binding on request date: _____ time: _____

hours of operation: _____

Unloading: dimensions: _____ l _____ w _____ h
weight: _____ kg

Dismantling: **Forklift truck with driver** **Crane** up to ____ t capacity

binding on request date: _____ time: _____

hours of operation: _____

Collection/loading: dimensions: _____ l _____ w _____ h
weight: _____ kg

Please make copies of this form, if you require more forklift trucks and cranes for assembling or dismantling your stand.
Subject to the general traffic situation on the access roads, in the loading yards or in the exhibition halls, which is beyond the control of the ServicePartner.
The ServicePartner may charge ½ hour for delivery/removal if the exhibitor fails to cancel a binding order at least 24 hours in advance.

4. Empty containers

Storage including collection from and returning to stand: yes no

VAT ID number of exhibitor:

The stickers for marking your empty containers are available for collection from the forwarding agent's office in the Exhibition Center Nuremberg (see below). Please collect these stickers and mark your empty containers before they are collected. The packaging material/empty packaging must be ready for collection on the stand in a form suitable for transport and bundled if necessary. Packaging costs are charged by the forwarding agent according to time and outlay.

5. Packed goods

Storage including collection/delivery: yes no

The storage of packed goods (= packaging material with contents) and objects of value, e.g. pallet trucks, lifting equipment, ladders, etc., must be registered separately. For insurance reasons, these goods are stored separately in a closed warehouse. The goods are only returned in exchange for a signed receipt.

6. Forwarding insurance

We do not require insurance.

Please note:

The organization of transport aids (lift trucks, cranes etc.) requires detailed planning in advance. Handling can only take place at the times required by you if the order is placed on this form in time (see above for return deadline). **Orders placed at short notice may be subject to considerable waiting times.**
All services will be charged according to the current tariffs for exhibition transport services.
The ServicePartner settles accounts with exhibitors during the event. The invoice may also be paid in the forwarding agent's office. The following credit cards are accepted: MasterCard, American Express, VISA. Unless otherwise agreed, the invoice will only be made out to the exhibitor listed in the index and/or the stand construction company.

ServicePartners:

Halls 3–7A **, NCC Ost **
Schenker Deutschland AG
Messezentrum Nürnberg
ServicePartnerCenter
90471 Nürnberg
Tel +49 (0) 9 11. 8 17 48-0
Fax +49 (0) 9 11. 8 17 48-25
fairs.nuernberg@dbschenker.com
www.schenkerfairs.com

Halls 1, 2, 8–12 **, NCC West **, NCC Mitte**
Kühne + Nagel (AG & Co.) KG
Messezentrum Nürnberg
ServicePartnerCenter
90471 Nürnberg
Tel +49 (0) 9 11. 98 18 56-0
Fax +49 (0) 9 11. 98 18 56-29
exposevice.nuernberg@kuehne-nagel.com
www.kuehne-nagel.com

** If your exhibition goods are transported to Nuremberg by Schenker, Kühne + Nagel or their approved partners, all other services at the exhibition will also be provided by these partners and the hall allocation is not binding.

* If necessary, NürnbergMesse is entitled to have the service ordered provided by another ServicePartner. In this case, the customer will be notified of the other ServicePartner in good time.
With our authorized signature below, we acknowledge acceptance of all items of the General and Special Terms of Business of NürnbergMesse and the General Terms of Business and the Special Conditions for Services of the ServicePartner.

Place and date

Company stamp and authorized signature

Special Conditions for Services provided by ServicePartners (Forwarding agent, empty containers storage)

- These exhibition transport tariffs are applicable for all services provided by the exhibition forwarding agent for delivery and collection of exhibition goods for exhibitors in the Exhibition Center Nuremberg. These charges are based on current regulations, wages and tariffs for a 5-day week. The rates shown are net.
- All orders placed in accordance with exhibition transport tariffs are governed by the latest edition of the German Freight Forwarders' Standard Terms and Conditions (ADSp).
- The forwarding agent's liability ends when the exhibition goods are delivered to the exhibitor's stand, regardless of whether the exhibitor or his representative is in attendance. The earliest possible delivery of your goods to the marked exhibition stand is on the first official day of assembly. Delivery is made to the designated stand from the first official assembly day onwards. It is essential for reliable and timely delivery that each package is clearly marked with the receiver's name and the exact designation of event and exhibition stand. For return transport, liability first commences on collection from the exhibition stand, whether or not dispatch notes have already been handed into the forwarding agent's office. Special requirements must be notified in writing in advance.
- Building and fire regulations prohibit the storage of empty containers in the exhibition halls during the event. The forwarding agent will arrange collection and storage on receipt of an order. The organizer has decreed that empty containers still in the exhibition halls and/or in the loading yards after expiry of the official assembly and dismantling periods may be removed by the forwarding agent, even if no order is received from the exhibitor. The costs incurred will be charged to the exhibitor. The storage of packages with their contents should be specially notified when placing orders.
- Complaints must be made immediately following receipt of the goods and are to be registered in writing at the forwarding agent's office; verbal claims are not admissible.
- All charges shown are net and are subject to VAT at the statutory rate.
- Please address direct deliveries to the exhibition stand as follows:
Name of exhibitor
c/o event, hall/stand
Messezentrum, 90471 Nürnberg
- Please contact the responsible forwarding agent if your goods are to be stored temporarily and delivered to the stand by the forwarding agent.



Fairground handling tariff for trade fairs and exhibitions in Nuremberg

- Part-load**
 - Up to 2,500 kg freight weight**
 - Unloading/loading** the truck at/from exhibition site or warehouse, warehousing during assembly and dismantling phase max. 3 days, weighing, delivery/ collection to/from exhibition stand, per 100 kg or part thereof

per direction	EUR 27.00
minimum 200 kg	EUR 54.00
 - Warehousing** from 4th day of storage during assembly and dismantling per day per 100 kg or part thereof EUR 1.35
 - Surcharge for bulky goods 1 m³ (= 200 kg) Surcharge for heavy items over 200 kg 50 %
 - Over 2,501 kg freight weight**
 - Unloading/loading/delivery to stand/collection from exhibition stand** as per outlay
 - Personnel and equipment** (see Item 3.)
 - Storage charge** per m³ or part thereof and month EUR 11.00
- Customs goods**
 - Transit handling** at post, airport and main customs offices for transport to the Exhibition Center EUR 65.00
 - Rolling charges**
 - From airport to Exhibition Center per 100 kg or part thereof

minimum 200 kg	EUR 17.00
	EUR 34.00
 - Unloading/loading** the truck at/from exhibition site or warehouse, warehousing during assembly and dismantling phase max. 3 days, weighing, delivery/ collection to/from exhibition stand, per 100 kg or part thereof per direction

minimum 200 kg	EUR 27.00
	EUR 54.00
 - Warehousing** from 4th day of storage during assembly and dismantling per day per 100 kg or part thereof EUR 1.35
 - Surcharge for bulky goods 1 m³ (= 200 kg) Surcharge for heavy items over 200 kg 50 %
 - Customs handling** at exhibition site
 - Temporary importation, Carnet ATA, re-exportation each EUR 105.00
 - Final importation (see Item 2.6.1)
 - Additional charge per tariff item EUR 12.00
 - Final importation of sample and promotional materials (see Item 2.6.1)
 - Dispatch note/security deposit for declaration of intended use (0.2 % of CIF value) minimum EUR 15.00
 - Charges** for customs inspection officials etc. as per outlay
 - Translation of trade invoices per page EUR 20.00
 - Personnel and equipment**
 - Personnel** Team leader/slinger per hour EUR 43.10
Transport workman per hour EUR 39.50
 - Cranes**

up to 30 t	per hour EUR 150.00
up to 45 t	per hour EUR 165.50
larger than 45 tons by arrangement	

Half an hour is charged for travel in each direction.
 - Forklift truck with driver**

up to 3 t	per hour EUR 107.60
up to 5 t	per hour EUR 116.70
up to 8 t	per hour EUR 132.50
larger than 8 tons by arrangement	
 - Additional equipment**

Maffi (special flat-bed trailer)	per hour EUR 34.00
Pallet truck	per hour EUR 11.00
Truck	per hour EUR 8.50
Jib type crane	per hour EUR 20.00
 - The minimum **charging unit for personnel** and equipment is 1.0 hour; parts of hours will be rounded up to units of 0.5 hours.
 - Incidental material** on request
 - Containers and platforms available for rental** on request
 - Turn-round of swap bodies** per unit EUR 205.00
Pick-up and taking to truck park; retrieval and positioning after event
 - Storage of empty containers** The storage of empty containers in the exhibition halls or in or near the exhibition stands is prohibited by the building and fire regulations. Collection from exhibition stand, measurement, storage and returning to exhibition stand (including all surcharges) per m³ or part thereof EUR 45.00
 - Packed goods**
 - Short-term** up to 3 months Collection from exhibition stand, measurement, storage in closed warehouse and return after the end of the exhibition per m³ or part thereof and month EUR 65.80
 - Long-term** over 3 months
 - Collection from exhibition stand, delivery to store, storage per m³ or part thereof minimum

up to 10 m ³	EUR 48.00
up to 20 m ³	EUR 30.50
up to 30 m ³	EUR 27.50
more than 30 m ³	EUR 24.50
	EUR 21.50
 - Removal from storage and returning to exhibition stand (see Item 5.2.1)
 - Storage charge per month

minimum	EUR 11.50
up to 10 m ³	EUR 6.25
up to 20 m ³	EUR 5.75
up to 30 m ³	EUR 5.40
more than 30 m ³	EUR 5.25
 - Incidental charges per order** Commission (2 %) for freight delivery, C.O.D etc. minimum EUR 5.00
 - Air freight** Atlas fee EUR 18.00
Assignment charge according to outlay
 - Surcharges**
 - Surcharges for personnel and equipment

Overtime 17:00 – 20:00	25 %
Nights 20:00 – 6:00	50 %
Saturdays	25 %
Sundays	50 %
Public holidays	100 %

(The surcharge is based on the day and time of performance of work.)
 - Forwarding insurance SpV by value of goods

Nuremberg, Germany
14-16.3.2017



embeddedworld2017

Exhibition&Conference
... it's a smarter world

Return to
NürnbergMesse GmbH
MesseService
Messezentrum
90471 Nürnberg
Tel +49 (0) 9 11. 86 06-80 00
Fax +49 (0) 9 11. 86 06-80 01
messe-service@nuernbergmesse.de

Contractor *
Gartengestaltung & Service Ronald Grabinger
Trierer Straße 52
90469 Nürnberg
Tel +49 (0) 9 11. 86 06-52 14
Fax +49 (0) 9 11. 86 06-64 39
Mobile phone 0171. 3 08 72 05
info@grabinger-gartenservice.de

Company _____

Street _____

Postcode, Town, Country _____

Tel _____

Fax _____

E-mail _____

Return deadline **Hall/Stand**
14.12.2016

Person to contact _____

Tel _____

Mobile phone _____

Fax _____

Order

Equipment	Designation	Qty.	Rental period
	<p>1. Flat truck loading area 1000 x 600 mm max. load 300 kg</p> <p>per hour EUR 6.00 per day EUR 51.70</p> <p>delivery/ collection EUR 18.50</p>	_____	<p>Date: from ___ to ___</p> <p>Time: from ___ to ___</p>
	<p>2. Optiliner loading area 900 x 600 mm max. load 400 kg</p> <p>per hour EUR 6.00 per day EUR 51.70</p> <p>delivery/ collection EUR 18.50</p>	_____	<p>Date: from ___ to ___</p> <p>Time: from ___ to ___</p>
	<p>3. C + truck loading area 1000 x 700 mm max. load 500 kg</p> <p>per hour EUR 7.70 per day EUR 51.70</p> <p>delivery/ collection EUR 18.50</p>	_____	<p>Date: from ___ to ___</p> <p>Time: from ___ to ___</p>
	<p>4. Pallet lift truck loading area 1150 x 510 mm max. load 2000 kg</p> <p>per hour EUR 12.50 per day EUR 119.00</p> <p>delivery/ collection EUR 18.50</p>	_____	<p>Date: from ___ to ___</p> <p>Time: from ___ to ___</p>

VAT ID number of exhibitor:

IMPORTANT

All prices including VAT at the statutory rate. Prices for several days possible by arrangement.

Direct delivery/collection to/from the exhibition stand takes place by prior telephone appointment and is subject to an additional one-off charge of EUR 18.50.

Trucks are rented on payment of a deposit of EUR 100 which is refunded if the truck is returned in good condition.

If the delivery of the hand truck is not accepted, the person placing the order will be charged for the rental plus delivery.

Cancellations are only possible up to 10 days before the official assembly date. The services ordered will be billed if cancelled later.

Complaints concerning the extent of services charged are to be checked and reported to the ServicePartner before dismantling the stand. Complaints cannot be accepted after the event because there is no possibility of properly checking the services provided.

Please fill in for payment by credit card:

Issuer : MasterCard VISA American Express

Card no.: _____ / _____ / _____

Card verification no.: (The last 3 digits next to the signature on the back of the card or for AMEX 4 digits on the front)

Expiry date : _____

Holder of card: _____

We authorize Gartengestaltung & Service Ronald Grabinger to debit the invoice amount from the above-mentioned credit card.

Signature: _____

* If necessary, NürnbergMesse is entitled to have the service ordered provided by another ServicePartner. In this case, the customer will be notified of the other ServicePartner in good time.

With our authorized signature below, we acknowledge acceptance of all items of the General and Special Terms of Business of NürnbergMesse and the General Terms of Business and the Special Conditions for Services of the ServicePartner.

Place and date

Company stamp and authorized signature

Nuremberg, Germany
14–16.3.2017



embeddedworld2017
Exhibition&Conference
... it's a smarter world

Return to
NürnbergMesse GmbH
MesseService
Messezentrum
90471 Nürnberg
Tel +49 (0) 9 11. 86 06-80 00
Fax +49 (0) 9 11. 86 06-80 01
messeservice@nuernbergmesse.de

Contractor *
SAG GmbH
ServicePartnerCenter
Messezentrum
90471 Nürnberg
Tel +49 (0) 9 11. 81 88 18-0
Fax +49 (0) 9 11. 81 88 18-19
sag-messe@sag.eu

Company _____

Street _____

Postcode, Town, Country _____

Tel _____

Fax _____

E-mail _____

Return deadline
14.12.2016

Hall/Stand

Person to contact _____

Tel _____

Fax _____

Invoice address (only if different) _____

Order

1. Working platforms (charged by calendar day) Daily rental charges without operating staff

- 1.1 Articulated work platform (cherry picker) up to 10 m, lateral working radius approx. 5 m EUR 213.80 / day
assembly from _____ till _____ piece(s) ____ day(s)
assembly from _____ till _____ piece(s) ____ day(s)
dismantling from _____ till _____ piece(s) ____ day(s)
dismantling from _____ till _____ piece(s) ____ day(s)

- 1.2 Scissor work platform up to 7 m EUR 125.60 / day
assembly from _____ till _____ piece(s) ____ day(s)
assembly from _____ till _____ piece(s) ____ day(s)
dismantling from _____ till _____ piece(s) ____ day(s)
dismantling from _____ till _____ piece(s) ____ day(s)

- 1.3 Scissor work platform up to 12 m EUR 182.70 / day
assembly from _____ till _____ piece(s) ____ day(s)
assembly from _____ till _____ piece(s) ____ day(s)
dismantling from _____ till _____ piece(s) ____ day(s)
dismantling from _____ till _____ piece(s) ____ day(s)

- 1.4 Delivery and collection of each work platform EUR 91.40 / piece
delivery on _____ piece(s) + collection on _____ piece(s)
delivery on _____ piece(s) + collection on _____ piece(s)
delivery on _____ piece(s) + collection on _____ piece(s)
delivery on _____ piece(s) + collection on _____ piece(s)

2. Working equipment (charged by calendar day)

- 2.1 Man lift up to 9.45 m, motor driven, including delivery and collection EUR 97.90 / day
assembly from _____ till _____ piece(s) ____ day(s)
assembly from _____ till _____ piece(s) ____ day(s)
dismantling from _____ till _____ piece(s) ____ day(s)
dismantling from _____ till _____ piece(s) ____ day(s)

- 2.2 Load lift up to 5.75 m, manual operation, including delivery and collection EUR 97.90 / day
assembly from _____ till _____ piece(s) ____ day(s)
assembly from _____ till _____ piece(s) ____ day(s)
dismantling from _____ till _____ piece(s) ____ day(s)
dismantling from _____ till _____ piece(s) ____ day(s)

* If necessary, NürnbergMesse is entitled to have the service ordered provided by another ServicePartner. In this case, the customer will be notified of the other ServicePartner in good time.
With our authorized signature below, we acknowledge acceptance of all items of the General and Special Terms of Business of NürnbergMesse and the General Terms of Business and the Special Conditions for Services of the ServicePartner.

VAT ID number of exhibitor:

3. Special vehicles – equipment price on request

4. Work at hourly rate

All prices in EURO plus VAT at the statutory rate.

Orders must be received by the organizer in a complete and correct form within the deadline set for the respective event. SAG GmbH is under no obligation to provide services for orders that do not meet these requirements.
Orders for mains power connections, suspensions, truss and compressed air connections – in so far as SAG GmbH can still process such orders or changes to existing orders – will be subject – from 3 weeks prior to the event – to a surcharge by SAG GmbH of 25 %. Other articles/services will be subject – from 14 days prior to the event – to a surcharge of 25 % for services according to a fixed price and/or 50 % for services according to time expenditure.

The services ordered must be paid without delay on receipt of the invoice.

The invoice may be issued before the start of assembly or dismantling.

Payment must be received by not later than 3 days before handover.

A fee of 50 % of the rental charge per equipment item will be charged for cancellations at short notice (up to 24 h before the day of rental).

Cancellations can no longer be accepted after this time.

The rented equipment must be available on the stand ready for collection at the end of the rental period.

If the vehicle cannot be collected from the stand for reasons for which the exhibitor/stand construction company is to blame, the daily rental charge per equipment item will be payable.

Note for customers:

The conditions of SAG GmbH are expressly accepted on signing the contract and also apply to any subsequent rental of equipment or orders.

The orderer ensures that the equipment is used only by persons

– of at least 18 years old,

– in possession of a valid driving authorization,

– trained in the operation, setting up and function of working equipment.

The user himself is responsible for trickle charging the batteries of working platforms during the rental period.

Please note that only working platforms offered by the ServicePartner SAG GmbH are allowed to be used on the exhibition site!

Place and date _____

Company stamp and authorized signature _____

Working platforms / working equipment – description

for Item 1.1

Articulated work platform

- all functions can be controlled from the platform
- electro-hydraulic drive
- working height approx. 11 m
- weight approx. 7,100 kg
- lateral radius at 5 m height approx. 7 m
- max. load 220 kg

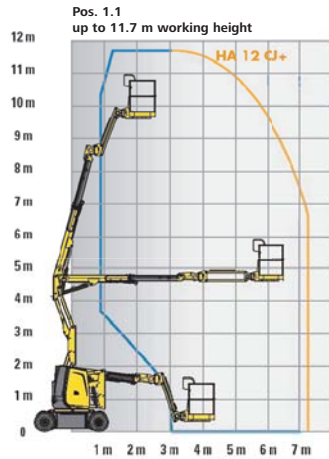

for Item 1.2

Scissor work platform

- all functions can be controlled from the platform
- electro-hydraulic drive
- slim design
- without supporting device
- working height approx. 7 m
- max. load capacity 227 kg
- platform size 1.64 m x 0.76 m
- unloaded weight approx. 1,500 kg

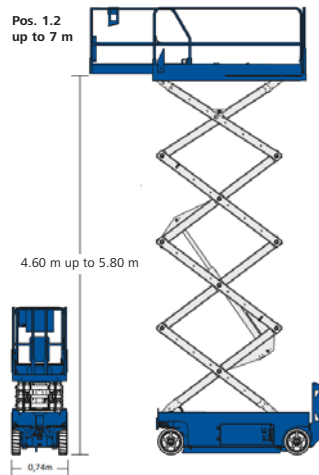

for Item 1.3

Scissor work platform

- all functions can be controlled from the platform
- electro-hydraulic drive
- without supporting device
- working height 10-12 m
- max. load capacity 318-450 kg
- platform size 2.26 m x 1.16 m
- unloaded weight from 2,450 kg

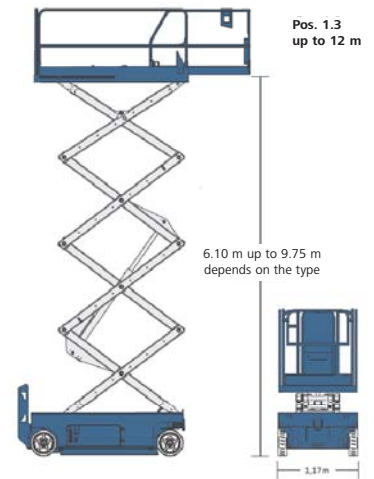

for Item 2.1

Man lift

- 230 V/16 A drive
- max. load capacity 140 kg
- unloaded weight 300 kg
- working height approx. 9.40 m
- with supporting device

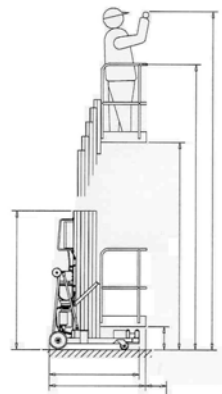

for Item 2.2

Load lift

- rated load 250 kg
- lifting height 6 m
- unloaded weight 140 kg
- with supporting device

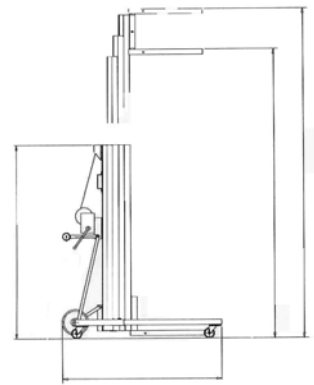

Further information and the Special Conditions for Services of SAG GmbH for working platforms / working equipment can be found on our Internet site at www.sag-servicepartner.de.

Nuremberg, Germany
 14-16.3.2017



Return to
 NürnbergMesse GmbH
 MesseService
 Messezentrum
 90471 Nürnberg
 Tel +49 (0) 9 11. 86 06-80 00
Fax +49 (0) 9 11. 86 06-80 01
 messeservice@nuernbergmesse.de

Contractor *
 Gartengestaltung & Service Ronald Grabinger
 Trierer Straße 52
 90469 Nürnberg
 Tel +49 (0) 9 11. 86 06-52 14
 Fax +49 (0) 9 11. 86 06-64 39
 Mobile phone 0171. 3 08 72 05
 info@grabinger-gartenservice.de

Company _____

Street _____

Postcode, Town, Country _____

Tel _____

Fax _____

E-mail _____

Return deadline **Hall/Stand**
14.12.2016

Person to contact _____

Tel _____

Mobile phone _____

Fax _____

Order

Equipment	Designation	Qty.	Rental period
	Article 41322 Stepladder with rungs, length extendible 2.40 – 4.05 m per hour EUR 28.50 price per day from 10 hours EUR 265.60 delivery/collection EUR 25.00	_____	Date: from _____ to _____ Time: from _____ to _____
	Article 41194 Telescopic multi-purpose ladder, length 3.35 m per hour EUR 21.00 price per day from 10 hours EUR 185.00 delivery/collection EUR 25.00	_____	Date: from _____ to _____ Time: from _____ to _____
	Article 41310 Stepladder, double-sided access, length 2.75 m per hour EUR 21.00 price per day from 10 hours EUR 185.00 delivery/collection EUR 25.00	_____	Date: from _____ to _____ Time: from _____ to _____
	Article 41599 Stepladder, single-sided access, length 3.40 m per hour EUR 17.50 price per day from 10 hours EUR 150.20 delivery/collection EUR 25.00	_____	Date: from _____ to _____ Time: from _____ to _____
	Article 40360 Stepladder, double-sided access, length 2.35 m per hour EUR 15.40 price per day from 10 hours EUR 115.50 delivery/collection EUR 25.00	_____	Date: from _____ to _____ Time: from _____ to _____

VAT ID number of exhibitor:

IMPORTANT

All prices including VAT at the statutory rate.
Direct delivery/collection to/from the exhibition stand takes place by prior telephone appointment and is subject to an additional one-off charge of EUR 25. This charge also includes instructions on the use of the rented ladders by our staff, which you must acknowledge at the time of delivery.
The rental is subject to payment of a deposit of EUR 100.00, which is refunded when the ladders are returned in good condition.

If the delivery of the ladders ordered is not accepted, the person placing the order will be charged for the rental plus delivery.
 Cancellations are only possible up to 10 days before the official assembly date. The services ordered will be billed if cancelled later.

Complaints concerning the extent of services charged are to be checked and reported to the ServicePartner before dismantling the stand. Complaints cannot be accepted after the event because there is no possibility of properly checking the services provided.

Please fill in for payment by credit card:

Issuer : MasterCard VISA American Express

Card no. : _____ / _____ / _____

Card verification no. : (The last 3 digits next to the signature on the back of the card or for AMEX 4 digits on the front)

Expiry date : _____

Holder of card: _____

We authorize Gartengestaltung & Service Ronald Grabinger to debit the invoice amount from the above-mentioned credit card.

Signature: _____

* If necessary, NürnbergMesse is entitled to have the service ordered provided by another ServicePartner. In this case, the customer will be notified of the other ServicePartner in good time.
 With our authorized signature below, we acknowledge acceptance of all items of the General and Special Terms of Business of NürnbergMesse and the General Terms of Business and the Special Conditions for Services of the ServicePartner.

Place and date

Company stamp and authorized signature

Nuremberg, Germany
14-16.3.2017



embeddedworld2017
Exhibition & Conference
... it's a smarter world

Return to
NürnbergMesse GmbH
MesseService
Messezentrum
90471 Nürnberg
Tel +49 (0) 9 11. 86 06-80 00
Fax +49 (0) 9 11. 86 06-80 01
messe-service@nuernbergmesse.de

Contractor *
Engelhardt & Co. Sicherheit GmbH
Messezentrum
90471 Nürnberg
Tel +49 (0) 9 11. 98 11 88-0
Fax +49 (0) 9 11. 98 11 88-88
engelhardt@engelhardt-sicherheit.de
www.engelhardt-sicherheit.de

Company
Street
Postcode, Town, Country
Tel
Fax
E-mail

Return deadline 14.12.2016
Hall/Stand
Person to contact
Tel
Fax
Invoice address (only if different)

Order (Binding, Special Conditions for Services overleaf)

Stand size:

Guarding of stands

Cost per hour EUR 25.00
plus VAT at the statutory rate

Number of security guards:

Assembly

Date: from to
Time: from to

During event

Date: from to
Time: from to

Dismantling

Date: from to
Time: from to

Please enter the name of authorized stand dismantling personnel/company in every case:

Surcharges:

Orders received later than 14 days before the start of the event will be billed an express surcharge of 25 %, subject to a minimum surcharge of EUR 10 per order.

Stand guarding is only carried out at night by the stand guard relieving the stand/assembly staff and vice versa. If guarding is required during the day, this must be stated separately on the order form.

* If necessary, NürnbergMesse is entitled to have the service ordered provided by another ServicePartner. In this case, the customer will be notified of the other ServicePartner in good time.

With our authorized signature below, we acknowledge acceptance of all items of the General and Special Terms of Business of NürnbergMesse and the General Terms of Business and the Special Conditions for Services of the ServicePartner.

VAT ID number of exhibitor:

VAT ID number input boxes

Remarks:

Please note Info 4, 2.5 - "Security".

ServicePartner:

Engelhardt & Co.
Sicherheit GmbH
Messezentrum Nürnberg
ServicePartnerCenter
Tel +49 (0) 9 11. 98 11 88-0
Fax +49 (0) 9 11. 98 11 88-88

Please fill in for payment by credit card:

Issuer: MasterCard VISA American Express
Card no.:
Card verification no.: (The last 3 digits next to the signature on the back of the card or for AMEX 4 digits on the front)

Expiry date:
Holder of card:

We authorize Engelhardt & Co. Sicherheit GmbH to debit the invoice amount from the above-mentioned credit card.

Signature:

Place and date

Company stamp and authorized signature

Special Conditions for Services provided by Engelhardt & Co. Sicherheit GmbH (Guarding of stands)

1. General performance of security service

The security company performs its activities under a contract for services with its personnel being employed in the capacity of agents. The selection of the personnel employed and the authority to issue instructions are incumbent on the ServicePartner.

The latter is solely responsible for compliance with all legal, governmental, social law and industrial insurance obligations in respect of its employees.

2. Contract for services

The contract for security services takes effect on receipt of the written order on the order form overleaf and after written confirmation of the order by the ServicePartner. The order form must bear a company stamp and authorized signature.

Orders at short notice are accepted directly in the office of the ServicePartner, but no obligation to perform the service exists until the order is confirmed in writing.

The signatory of the order form declares that he is authorized to place the order.

If the order is placed by a third party, e.g. a stand construction company, the person placing the order is liable personally if no proof of authority is provided on or after placing the order.

3. Contract performance

The ServicePartner undertakes to provide guarding of the stand indicated in the application during the agreed period by a reliable employee who will be solely responsible for the security of the stand. The contractual services are to be completed solely in accordance with the instructions for guarding the stand, which contain detailed regulations for performing the services. The instructions can be inspected in the offices of the company in the ServicePartnerCenter.

To verify the time spent on duty, the watchman shall complete a time sheet, which shall be signed by the exhibitor when the guard is relieved.

The time sheet shall be the basis for accounts rendered.

4. Duration of contract

The contract in each individual case will be effective for the period specified in the order. The full rate shall be charged for every half hour or part thereof. The minimum charge shall be for 4 hours per deployment.

5. Complaints

Complaints of any kind in respect of the performance of the service or other irregularities shall be reported immediately on being discovered to the management of the ServicePartner for the purpose of remedial action. Failure to report any complaints promptly may void any rights to which the client may be entitled on account of such complaints, if this means it is no longer possible to reliably determine the facts of the case. The ServicePartner shall bear no liability whatsoever for consequential damage that could have been avoided if the complaint had been reported in time.

6. Liability and limitation of liability

6.1 In the case of any claims arising for damage on whatever legal grounds, the ServicePartner shall be liable only to the extent such damage may have been caused by it, its statutory representatives or its staff either intentionally or by gross negligence.

6.2 The ServicePartner shall not be liable for damage caused by the actions of security personnel that are not connected with the actual security service, such as the operation and care of machinery, boilers, electrical or similar plants, if such actions were performed by the security personnel at the request of the client.

6.3 The client is obliged to assert claims in writing immediately after becoming aware of them.
Clause 5 applies accordingly.

6.4 All claims of the client arising out of this contract expire by statutory limitation after a period of one year.

Commencement of limitation period: on becoming aware of claim.

6.5 The maximum amount of liability under clause 6.1 shall be limited as follows:

EUR 1,000,000.00	for personal injuries
EUR 500,000.00	for damage to property
EUR 15,000.00	for the loss of items guarded

7. Payment procedure

The service provided is due for payment in full immediately. The invoice amount is collected from the stand in cash by a representative of Engelhardt & Co. in all cases. Please inform the stand personnel accordingly and provide them with the necessary amount in cash. Cashless payment is only possible by separate agreement.

8. The place of jurisdiction and performance

is Nuremberg for both parties.

The agreed place of jurisdiction for asserting claims for debt payment is Nuremberg.

Permanent parking permits for cars, travel tickets

S3.50

Nuremberg, Germany
14-16.3.2017



embeddedworld2017

Exhibition&Conference
... it's a smarter world

Return to
NürnbergMesse GmbH
MesseService
Messezentrum
90471 Nürnberg
Tel +49 (0) 9 11. 86 06-80 00
Fax +49 (0) 9 11. 86 06-80 01
messe-service@nuernbergmesse.de

Contractor *
Engelhardt & Co.
Parkraummanagement u. Service GmbH
Messezentrum, 90471 Nürnberg
Tel +49 (0) 9 11. 98 11 88-55
Fax +49 (0) 9 11. 98 11 88-58
info@engelhardt-parkservice.de
www.engelhardt-parkservice.de

Company _____
Street _____
Postcode, Town, Country _____
Tel _____
Fax _____
E-mail _____

Return deadline
14.12.2016

Hall/Stand
Very important!

Person to contact _____
Tel _____
Fax _____
Invoice address (only if different) _____

Order (binding, Special Conditions for Services overleaf)

Permanent parking permits for cars

- Parking spaces on official parking areas (e.g. P Süd/P Ost)
_____ Qty. at **EUR 27.00** EUR _____
(including VAT at the statutory rate)
- Parking spaces in loading yards 1, 2/3/4, 5 (**limited spaces!**)
_____ Qty. at **EUR 75.00** EUR _____
(including VAT at the statutory rate)

Please state your hall number to make sure you receive the right permanent parking permits.

The permanent parking permits are valid from Tue 14.3 – Thu 16.3.2017.

Travel tickets

for the Nürnberg integrated transport system. The ticket entitles the holder to unlimited travel by underground, tram, bus or urban railway in the Nürnberg region (zones 100 and 200) within the stated period of time.

- _____ Qty. 1-day ticket at EUR 7.90 EUR _____
- _____ Qty. 2-day ticket at EUR 15.80 EUR _____
- _____ Qty. 3-day ticket at EUR 23.70 EUR _____
- _____ Qty. 7-day ticket at EUR 25.30 EUR _____

The first journey can be made on any day. Every 1/2/3-day ticket must be stamped before the first journey.

The 7-day ticket is valid from Sun 12.3 – Sat 18.3.2017.

Fees

Processing fee EUR **3.50**

Total amount

(Permanent parking permits, travel tickets and fees) **EUR** _____

Payment procedure

After receipt of your order, we will send you an invoice by **e-mail** or **fax** (**please state address/fax no.**), which you then pay by a bank transfer to the account stated on the invoice, **quoting the invoice number**. **Parking permits and travel tickets are mailed with delivery note and note of payment approximately 4-6 weeks before the exhibition starts, subject to prior receipt of payment.**

Person to contact: E-mail or fax

If you wish to pay via your credit card account, please enter the following details in full:

Please charge the amount to our credit card account.

Issuer: MasterCard American Express
 VISA

Card no.: _____ / _____ / _____

Card verification no.: (The last three digits next to the signature on the back of the card or for AMEX 4 digits on the front of the card)

□ □ □ □

Valid until: _____

Holder of card: _____

ServicePartner:

Engelhardt & Co.
Parkraummanagement u. Service GmbH
Messezentrum Nürnberg
ServicePartnerCenter
Tel +49 (0) 9 11. 98 11 88-55
Fax +49 (0) 9 11. 98 11 88-58

* If necessary, NürnbergMesse is entitled to have the service ordered provided by another ServicePartner. In this case, the customer will be notified of the other ServicePartner in good time.

With our authorized signature below, we acknowledge acceptance of all items of the General and Special Terms of Business of NürnbergMesse and the General Terms of Business and the Special Conditions for Services of the ServicePartner.

Place and date

Company stamp and authorized signature

Special Conditions for Services provided by Engelhardt & Co. Parkraummanagement u. Service GmbH (Permanent parking permits for cars)

The marked parking areas are available for parking cars. They are manned on the days of the event from 7:00 to 19:00 or until 1 hour after the end of the event.

Permanent parking permits are valid only for cars.

The parking of trucks, trailers, vans, swap bodies, caravans and mobile homes is prohibited during the exhibition in the areas marked as parking areas, in the loading yards of the Exhibition Center Nuremberg (except for delivery, which is restricted to a maximum of 30 minutes) and in the "Große Straße". This regulation also applies to vehicles which give the impression of being trucks, trailers, vans, swap bodies, caravans and mobile homes.

Vehicles can be parked free of charge during the exhibition in the parking areas marked for this purpose by the organizer. The route to these parking areas only a few minutes drive from the Exhibition Center Nuremberg is signed and is also shown on the approach road maps handed out at the entrances to the loading yards.

The organizer is entitled to remove vehicles parked in the parking areas or the loading yards at 2:00 on the morning of the first day of the event by having them towed away at the cost of the vehicle owner or user. The exhibitor agrees to ensure that third parties appointed by him such as exhibition service companies, hauliers etc. also comply with these regulations.

Parking permits are mailed with delivery note and note of payment up to 10 days before the exhibition starts, subject to prior receipt of payment and availability of free spaces on the parking areas nearest the hall.

For orders received after this date, parking permits can be collected on payment from our office in the ServicePartnerCenter.

Permanent parking permits may also be obtained during the assembly period from all info counters located between the exhibition halls.

Any parking permits not required can be returned to our office until the last assembly day, but not after this date.

Lost parking permits cannot be replaced free of charge. The car park attendants will ensure that vehicles are parked properly – please follow their instructions.

No liability is accepted for injury to persons, damage to property or theft of the vehicle or its contents.

Mobile homes and caravans can be parked at the nearby Knaus Campingpark.

The erection of company signs, pennants or advertising is prohibited on the whole parking area. The place of jurisdiction and fulfillment is Nuremberg.

The multi-story car park closes 90 min. after the end of the event.

In accordance with Art. 3a, Para. 2 of the German Value Added Tax Act (UStG) and Art. 44 of the VAT Directive (MwStSystRL), VAT-free billing of services for exhibitions and trade fairs is only possible as part of a so-called service package. However, your order does not fulfil the conditions for a single service in accordance with Section 3a.4. Para. 2 p. 3 of the German VAT Implementation Decree (UStAE) of 1.12.2010, which has been supplemented and partly amended by the letter of the Federal Ministry of Finance dated 4.2.2011.

The services supplied are therefore billed with 19 % German VAT in accordance with the VAT provisions of Section 3a.4. Para. 3 No. 1 UStAE of 1.12.2010, which has been supplemented and partly amended by the letter of the Federal Ministry of Finance dated 4.2.2011, in conjunction with Art. 3a Para. 3 No. 1 UStG.

If relevant reciprocal agreements exist between your country and the Federal Republic of Germany, you still have the possibility of applying to the Federal Central Tax Office in Germany (www.bzst.de) for a refund of the German VAT.

Nuremberg, Germany
14–16.3.2017



Return to
 NürnbergMesse GmbH
 MesseService
 Messezentrum
 90471 Nürnberg
 Tel +49 (0) 9 11. 86 06-80 00
Fax +49 (0) 9 11. 86 06-80 01
 messeservice@nuernbergmesse.de

Company _____

Street _____

Postcode, Town, Country _____

Tel _____

Fax _____

E-mail _____

Return deadline	Hall/Stand
_____	_____
Person to contact _____	
Tel _____	
Fax _____	
Invoice address (only if different) _____	

Information on advertising possibilities

Take advantage of our Exclusive Marketing for embedded world and make your company stand out to trade visitors. Choose from an interesting range up from a BlowUp Column to a WalkingAct License. Set yourself apart from the competition!

We will be pleased to help you plan your advertising strategy for embedded world 2017.

We are interested in the following advertising measure:

Please send us an offer.

Please contact Andrea Göppel for detailed information, advice and bookings:

Tel +49 (0) 9 11. 86 06-84 45

Fax +49 (0) 9 11. 86 06-80 01

marketing-messeservice@nuernbergmesse.de



BlowUp Column



GigaFrame outdoor



Flying object

Nuremberg, Germany
14–16.3.2017



embeddedworld2017

Exhibition&Conference
... it's a smarter world

Return to
NürnbergMesse GmbH
MesseService
Messezentrum
90471 Nürnberg
Tel +49 (0) 9 11. 86 06-84 15
Fax +49 (0) 9 11. 86 06-84 47
hotels@nuernbergmesse.de

Company

Street

Postcode, Town, Country

Tel

Fax

E-mail

Return deadline
immediately

Hall/Stand

Person to contact

Tel

Fax

Invoice address (only if different)

Hotel Information

Example offers of our PartnerHotels in Nuremberg.

If interested in our service, we will send you a detailed offer by E-mail.

VAT ID number of exhibitor:

<input type="text"/>	<input type="text"/>	<input type="text"/>	<input type="text"/>	<input type="text"/>	<input type="text"/>	<input type="text"/>	<input type="text"/>	<input type="text"/>	<input type="text"/>	<input type="text"/>	<input type="text"/>	<input type="text"/>	<input type="text"/>	<input type="text"/>	<input type="text"/>	<input type="text"/>	<input type="text"/>	<input type="text"/>	<input type="text"/>
----------------------	----------------------	----------------------	----------------------	----------------------	----------------------	----------------------	----------------------	----------------------	----------------------	----------------------	----------------------	----------------------	----------------------	----------------------	----------------------	----------------------	----------------------	----------------------	----------------------

Arrival

Departure

Type of room (SR/DR)

Number

Sheraton Hotel Carlton *****

- Located in Downtown (central railway station)
- Non-smoker-hotel
- Restaurant, bar
- Rooms with air-conditioning, WLAN, PayTV
- CarltonSpa high above the roofs of Nuremberg
- 9 minutes by underground to fairground

Arvena Park Hotel ****

- Close to fairground
- Restaurant, bar, beer garden
- Sauna, steam bath, solarium
- Free parking
- 4 minutes by underground to fairground

Fürther Hotel Mercure Nürnberg West ****

- Located at Fürth with convenient connection to motorway A73
- Approx. 20 minutes by car to reach the fairground
- Restaurant, hotelbar, terrace with swimming pool
- Own car parking in front of the hotel (upon a fee)
- Rooms with free wifi
- Convenient connection to public transport
- Fitness room

acomhotel nürnberg ***

- Breakfast restaurant, 24-hour bistro
- Direct connection to the public transportation
- Lobby and bar
- Close to airport
- 25 minutes by underground to fairground
- Parking and underground car park

Motel One **

- Two times close to Old Town (central railway station and Plärrer)
- Non-smoker-hotels
- Rooms with air-conditioning, WLAN
- Bar, garage parking
- 9 – 12 minutes by underground to fairground

Art & Business Hotel

- Located in Downtown (central railway station)
- Non-smoker-hotel
- Art Bar
- Air-conditioning, PayTV
- Broadband Internet access
- 9 minutes by underground to fairground

Yes, we are interested in your hotel booking service.
We request further information

- by e-mail to the above address
 by fax
 by phone

On the following website you can find all our offered hotels with availability and prices and you can also book the hotel directly:



If you need more rooms you can also send the detailed request and we will contact you.

Please note:

We have negotiated **special terms** for you with most of our PartnerHotels. These terms apply only to bookings made via **MesseService**. We will be glad to submit a non-binding quote. All bookings are processed in the order of receipt.

Nuremberg, Germany
14–16.3.2017



embeddedworld2017

Exhibition & Conference

... it's a smarter world

Return to
NürnbergMesse GmbH
MesseService
Messezentrum
90471 Nürnberg
Tel +49 (0) 9 11. 86 06-80 00
Fax +49 (0) 9 11. 86 06-80 01
messe-service@nuernbergmesse.de

Contractor *
Congress- und Tourismus-Zentrale Nürnberg
Postfach 4248
90022 Nürnberg
Tel +49 (0) 9 11. 23 36-1 21, -1 22
Fax +49 (0) 9 11. 23 36-1 67
zv@ctz-nuernberg.de
tourismus.nuernberg.de

Company _____

Street _____

Postcode, Town, Country _____

Tel _____

Fax _____

E-mail _____

Return deadline immediately	Hall/Stand
--	-------------------

Person to contact _____

Tel _____

Fax _____

Invoice address (only if different) _____

Order

<input type="checkbox"/> Single room Qty. _____ Night/s _____ from/date _____	<input type="checkbox"/> Double room Qty. _____ Night/s _____ from/date _____	Category
<input type="checkbox"/> from EUR 120.00	<input type="checkbox"/> from EUR 150.00	S
<input type="checkbox"/> from EUR 90.00	<input type="checkbox"/> from EUR 115.00	I
<input type="checkbox"/> from EUR 65.00	<input type="checkbox"/> from EUR 80.00	II

Price including breakfast, service and VAT.

VAT ID number of exhibitor:

□□ □□□□□□□□□□□□□□

Please clearly enter name and full address below. This address is copied as reservation information to avoid mistakes in transferring:

Name/company: _____

Street: _____

Postcode, Town, Country: _____

Single room: _____ Double room: _____

No. of nights: _____ from (date): _____

Special room requirements:

To secure your booking request, please fill out your credit card details below:

Issuer: MasterCard American Express
 VISA Diners Club

Card no.: _____ / _____ / _____

Card verification no.: (The last 3 digits next to the signature on the back of the card or for AMEX 4 digits on the front) □□□□

Valid until: _____

Holder of card: _____

Travelling by: Air Rail Car

Arrival at hotel: approximately _____ a.m./p.m.

Standard of room: Bath Shower WC

The Congress- und Tourismus-Zentrale Nürnberg acts only as agent in reserving accommodation.

All requests for reservations will be dealt with in the order received. Reservations should therefore be submitted as early as possible.

All prices include breakfast, service and VAT.

If rooms are no longer available in the category requested, please provide rooms:

in a higher category in a lower category
 within 30 km radius

* If necessary, NürnbergMesse is entitled to have the service ordered provided by another ServicePartner. In this case, the customer will be notified of the other ServicePartner in good time.
With our authorized signature below, we acknowledge acceptance of all items of the General and Special Terms of Business of NürnbergMesse and the General Terms of Business and the Special Conditions for Services of the ServicePartner.

Place and date _____

Company stamp and authorized signature _____

Nuremberg, Germany
14–16.3.2017



embeddedworld2017

Exhibition & Conference
... it's a smarter world

Return to
NürnbergMesse GmbH
MesseService
Messezentrum
90471 Nürnberg
Tel +49 (0) 9 11. 86 06-80 00
Fax +49 (0) 9 11. 86 06-80 01
messeservice@nuernbergmesse.de

Contractor *
Business & Service Brigitte Schmedding GmbH
Messezentrum
90471 Nürnberg
Tel +49 (0) 9 11. 8 60 76-0
Fax +49 (0) 9 11. 8 60 76-11
info@business-und-service.de
www.business-und-service.de

Company

Street

Postcode, Town, Country

Tel

Fax

E-mail

Return deadline
immediately

Hall/Stand

Person to contact

Tel

Fax

Invoice address (only if different)

Request

Whether country guesthouse or 5-star hotel, central city location or charming Nuremberg countryside, for 100 persons or just one person – our room and hotel reservation service is tailored exactly to your needs.



VAT ID number of exhibitor:



Name of guest(s)

Please send an offer for

Price category	Price per night
<input type="checkbox"/> Price category I ** / ***	from EUR 77.00
<input type="checkbox"/> Price category II ***	from EUR 108.00
<input type="checkbox"/> Price category III *** / ****	from EUR 139.00
<input type="checkbox"/> Price category IV ****	from EUR 180.00
<input type="checkbox"/> Price category V **** / *****	from EUR 211.00

If unavailable:

next higher price group next lower price group

The prices stated are for a single room per night and including breakfast, service and VAT. All rooms are equipped with a shower/WC, mostly also with telephone, TV and minibar.

The price differences are due to facilities and location.

Category I hotels may be located on the city outskirts or up to 40 km away for well-attended exhibitions.

* If necessary, NürnbergMesse is entitled to have the service ordered provided by another ServicePartner. In this case, the customer will be notified of the other ServicePartner in good time.

With our authorized signature below, we acknowledge acceptance of all items of the General and Special Terms of Business of NürnbergMesse and the General Terms of Business and the Special Conditions for Services of the ServicePartner.

Travelling by car air rail

Number of single rooms double rooms

Date from _____ to _____

Number of nights _____

Descriptions of our price categories:

Price category I ** / ***

e.g. friendly hotel with restaurant and lounges in the Nuremberg region, approx. 30 – 45 minutes away from the exhibition centre by car or train.

Price category II ***

e.g. cosy and friendly hotel in Nuremberg with public transport facilities nearby – approx. 20 minutes to the exhibition centre.

Price category III *** / ****

e.g. comfortable city hotel centrally located in Nuremberg, with restaurant, bar, conference room, underground station nearby, approx. 15 minutes to the exhibition centre.

Price category IV ****

e.g. business hotel in the city centre, exclusive atmosphere, with restaurant, conference and banquet rooms, fitness/ wellness area, underground station nearby, approx. 10 minutes to the exhibition centre.

Price category V **** / *****

e.g. modern, elegant first-class hotel at the entrance to the old town centre, cultivated ambience, with restaurant, bar, conference and banquet rooms, fitness/ wellness area, underground station nearby, approx. 10 minutes to the exhibition centre.

Place and date

Company stamp and authorized signature

Nuremberg, Germany
14–16.3.2017



embeddedworld2017

Exhibition & Conference
... it's a smarter world

Return to
NürnbergMesse GmbH
MesseService
Messezentrum
90471 Nürnberg
Tel +49 (0) 9 11. 86 06-80 00
Fax +49 (0) 9 11. 86 06-80 01
messe-service@nuernbergmesse.de

Your ServicePartner *
Business & Service Brigitte Schmedding GmbH
Messezentrum
90471 Nürnberg
Tel +49 (0) 9 11. 8 60 76-0
Fax +49 (0) 9 11. 8 60 76-11
info@business-und-service.de
www.business-und-service.de

Company _____

Street _____

Postcode, Town, Country _____

Tel _____

Fax _____

E-mail _____

Return deadline _____
immediately

Hall/Stand _____

Person to contact _____

Tel _____

Fax _____

Invoice address (only if different) _____



Your advantages with Business & Service as ServicePartner of NürnbergMesse:

- Office conveniently located at Exhibition Centre Nuremberg
- Our service personnel do not need an extra exhibitor pass
- Personal, proficient and flexible on-site support guaranteed

Business & Service is a supplier of contract labour within the meaning of §1 of the German Law on Temporary Employment (known in German by its abbreviation "AÜG") and is in possession of a valid permit to rental out employees.

The following surcharges may be incurred in individual cases:

Surcharge for overtime above 9 hours	= 25 %
Night surcharge from 23:00 – 6:00	= 25 %
Surcharge on Sundays	= 50 %
Surcharge on public holidays	= 100 %

The minimum working time is 3 hours per day.

Orders received later than 14 days before the start of the event will be billed an express surcharge of 25 % per order.

All rates plus VAT at the statutory rate.

The following cancellation terms apply if we cannot deploy the hostesses elsewhere:

Until 28 days prior to employment	25 % of the rate
Until 14 days prior to employment	50 % of the rate
Until 7 days prior to employment	75 % of the rate
Under 7 days prior to employment	100 % of the rate

- EXTRA PACKAGE MARKETING**
Advance briefing/training of hostess by customer by phone or e-mail
One-off price EUR 90.00
- EXTRA PACKAGE – STYLING & MAKE-UP**
Professional hair styling and make-up.
Price on request. Ask for an individual offer.
- EXTRA PACKAGE – PROMOTION**
Costume depending on choice – from morphsuit to baroque costume
Ask for an individual offer. **Costume price for duration of exhibition (up to 3 days) approx. EUR 210.00**

VAT ID number of exhibitor:
□□ □□□□□□□□□□□□□□

Binding Order/Please tick:

HOSTESS WITHOUT knowledge of foreign languages
Price per hour **EUR 21.50**

HOSTESS WITH knowledge of foreign languages (conversational level)
Price per hour **EUR 22.50**

INTERPRETER HOSTESS
Price per hour **EUR 37.00**

HEAD HOSTESS
Price per hour **EUR 43.00**

HELPING HANDS for assembly and dismantling
Price per hour **EUR 21.50**

No. of staff required _____ Male _____ Female _____

Desired foreign language(s) _____

Employment date _____

Employment time _____

Briefing required – date/time _____

Company clothing will be provided

Neutral, uniform clothing is desired (including costume/suit)

Selection with Sedcard

You are welcome to choose your staff from sedcards.
Price EUR 53 (choice of max. 3, EUR 5.90 for each additional choice)

We leave the choice of staff to the agency (without extra cost).

We'll also be pleased to send you an offer for:

Model Presenter Qualified interpreter

* NürnbergMesse reserves the right to have the service you ordered provided by a different ServicePartner. In this case you will be advised the name of the service provider in good time.

With our authorized signature below, we acknowledge acceptance of all items of the General Terms of Business and Special Conditions for Services of the ServicePartner.

Place and date

Company stamp and authorized signature

Nuremberg, Germany
14–16.3.2017



Return to
NürnbergMesse GmbH
MesseService
Messezentrum
90471 Nürnberg
Tel +49 (0) 9 11. 86 06-80 00
Fax +49 (0) 9 11. 86 06-80 01
messeservice@nuernbergmesse.de

Your ServicePartner *
Business & Service Brigitte Schmedding GmbH
Messezentrum
90471 Nürnberg
Tel +49 (0) 9 11. 8 60 76-0
Fax +49 (0) 9 11. 8 60 76-11
info@business-und-service.de
www.business-und-service.de

Company _____

Street _____

Postcode, Town, Country _____

Tel _____

Fax _____

E-mail _____

Return deadline
immediately

Hall/Stand

Person to contact _____

Tel _____

Fax _____

Invoice address (only if different) _____



Exhibition Party on your stand



Customer retention in a relaxed atmosphere: Our theme evenings offer top culinary enjoyment from all over the world and guarantee varied entertainment.

Happy Hour **from EUR 36.50 per person**

Musical entertainment with DJ, five finger food snacks, beverages, up to two hours

Exhibition party **from EUR 67.00 per person**

Live music with band of your choice, buffet or flying buffet, beverages, duration up to three hours

Exhibition party PREMIUM **from EUR 89.00 per person**

Live music with band of your choice, buffet or flying buffet, beverages, bartender with two cocktails per person, decorations, lounge furniture, duration three hours

All prices are per person (for 50 or more persons) and include food, drinks package, logistics, service staff and equipment. The drink packages contain an allocation of the following drinks according to the type of the event: wine, soft drinks, beer, prosecco and juices.

We'll be pleased to make you a tailor-made offer:

No. of people: _____ Duration: _____

* NürnbergMesse reserves the right to have the service you ordered provided by another ServicePartner. In this case you will be advised the name of the service partner in good time.

With our authorized signature below, we acknowledge acceptance of all items of the General Terms of Business and Special Conditions for Services of the ServicePartner.

Place and date _____

VAT ID number of exhibitor:

Creative incentives, rousing exhibition parties, eye-catching attractions at your booth and unforgettable events in Nuremberg – we turn your presence into an impressive experience and ensure that you and your guests are excellently looked after – inside and outside the exhibition.

Interactive event marketing



Interactive event marketing for the B2B segment

Draw a lot of attention with some small special touches. Experience and create interaction. Focus on communication.

Programme ideas:

- Murder mystery game
- Cooking contest
- Gentleman Training
- Go-Cart Team Challenge
- Scavenger hunt
- Beer brewing course
- Prize draws
- Topic-specific quiz
- Alfred Dürer trail
- Medieval banquet
- Barista workshop

SHUTTLE SERVICE

Offer your guests a safe, comfortable means of transport:

- Chauffeur-driven car
- Bus shuttle

Possible routes:

Hotel -> Exhibition Centre -> Hotel
Exhibition Centre -> Munich airport/Frankfurt airport

Company stamp and authorized signature _____



As your ServicePartner we organize all activities and measures for your exhibition visit. Contact us for an individual offer!

Host an unusual event in the evening either at your stand or in Nuremberg itself.

We find a tailor-made solution to suit your wishes – for a cosy get-together or a formal dinner.

Events and locations in Nuremberg



Customer events

After a tiring day at the show or a successful business year, we organize the perfect event exactly to your requirements. Not just at the exhibition centre but everywhere!

Location:

- Restaurant
- Event hall
- _____
- Museum
- Conference room

Style:

- Modern
- Classical
- Lounge
- Historical
- _____
- Franconian
- Get Together
- Formal Dinner

Themed event:

- Las Vegas Night
- Futuristic circus
- _____
- Nostalgia meets elegance

Services:

- Artists/entertainers
- Technology
- Logistics
- _____
- Decoration
- Catering

Entertainment on your stand



Let a professional artist or entertainer communicate your brand message or take care of acquisition:

We are pleased to arrange various artists for you.

- DJ** **from EUR 500.00**
Duration 3 hours
- Bands (mobile or on stage)** **from EUR 650.00**
Musical style: _____
- Barkeeper** **EUR 5.90 per cocktail**
From 200 cocktails, for 2-4 hours
- iPad magician (walk act or stage show)** **from EUR 1,500.00**
Duration 2 hours
- Close Up** **from EUR 66.00 per hour**
Comedy, thimble rigger, magic (minimum performing times)
- Shoe Shine Boys event** **from EUR 1,200.00**
Per day performance (8 hours)
- Wine/gin tasting** **from EUR 45.00**
Per person 2 hours
- Mind-reading show** **from EUR 1,040.00**
Duration 4 hours
- Sketch artist** **from EUR 820.00**
Duration 3 hours

We'll be pleased to make you a tailor-made offer to meet your event requirements:

Date: _____

Time period: _____

Type of event: _____

Expected number of people: _____

* NürnbergMesse reserves the right to have the service you ordered provided by another ServicePartner. In this case you will be advised the name of the service partner in good time.

With our authorized signature below, we acknowledge acceptance of all items of the General Terms of Business and Special Conditions for Services of the ServicePartner.

Place and date _____

Company stamp and authorized signature _____

Hostesses and exhibition staff

S4.40

Nuremberg, Germany
14–16.3.2017



embeddedworld2017

Exhibition&Conference
... it's a smarter world

Return to
NürnbergMesse GmbH
MesseService
Messezentrum
90471 Nürnberg
Tel +49 (0) 9 11. 86 06-80 00
Fax +49 (0) 9 11. 86 06-80 01
messe-service@nuernbergmesse.de

Your ServicePartner *
Lorenz Projekte GmbH & Co. KG
Lorenz Office GmbH & Co. KG
Lorenz Technik GmbH & Co. KG
Dr.-Kurt-Schumacher-Str. 16, 90402 Nürnberg
Tel +49 (0) 9 11. 21 46 66 38
Fax +49 (0) 9 11. 21 46 66 99
messe@lorenz-personal.de

Company _____

Street _____

Postcode, Town, Country _____

Tel _____

Fax _____

E-mail _____

Return deadline _____
immediately

Hall/Stand _____

Person to contact _____

Tel _____

Fax _____

Invoice address (only if different) _____

Order



VAT ID number of exhibitor:

Our terms for our qualified and motivated fair staff are:

Qualifications	Hourly rate for bookings	Less than 14 days before the start of the event	Number of staff	Date from/to	Time from/to	Male/Female
Hostess without knowledge of foreign language	EUR 23.30	EUR 28.80	_____	_____	_____	_____
Hostess with knowledge of one foreign language	EUR 25.10	EUR 31.10	_____	_____	_____	_____
Hostess with knowledge of two foreign languages	EUR 26.70 - EUR 33.10	EUR 33.10	_____	_____	_____	_____
Head hostess (recommended for 5 or more hostesses)	EUR 30.50	EUR 37.75	_____	_____	_____	_____
Translator hostess	EUR 33.50	EUR 39.50	_____	_____	_____	_____
Certified interpreter	on request		_____	_____	_____	X
Assembly assistant **	EUR 26.60	EUR 29.60	_____	_____	_____	_____

** (without own work equipment) for stand assembly/dismantling

Description of work: _____

Foreign languages: English French Italian Spanish _____

Prices are quoted per hour plus VAT (at the statutory rate). The minimum order is 5 consecutive hours per operation day. The complete amount has to be paid in advance at the latest two weeks before the start of the event. The Lorenz Group is a temporary employment agency for the purposes of Art. 1 of AÜG (German Temporary Employment Act) and is in possession of a valid license for hiring out temporary staff. Please note that work on Sundays and public holidays may be subject to surcharges of 50 % per hour.

The cancellation terms are as follows:
Up to 10 days before the beginning of the task 50 % of the total amount
Up to 3 days before the beginning of the task 80 % of the total amount
We will arrange everything for you from providing staff through to billing. Our experienced and dedicated team is always available for you during the event. We appreciate your order and assure you our professional service. Please notify us your requirements as soon as possible and do not hesitate to contact us if you have any further questions by telephone +49 (0) 9 11. 21 46 66-38 or e-mail to messe@lorenz-personal.de.

* The contractual partner is the ServicePartner. NürnbergMesse GmbH will gladly recommend another ServicePartner on request. NürnbergMesse GmbH acts only as agent and accepts no liability whatsoever for the ServicePartner. With our authorized signature below, we acknowledge acceptance of all items of the General Terms of Business and Special Conditions for Services of the ServicePartner.

Place and date

Company stamp and authorized signature

Nuremberg, Germany
14-16.3.2017



embeddedworld2017

Exhibition&Conference
... it's a smarter world

Return to
NürnbergMesse GmbH
MesseService
Messezentrum
90471 Nürnberg
Tel +49 (0) 9 11. 86 06-80 00
Fax +49 (0) 9 11. 86 06-80 01
messeservice@nuernbergmesse.de

Contractor *
J. L. Orth GmbH Assekuranzmakler
Königstorgaben 9
90402 Nürnberg
Tel +49 (0) 9 11. 58 85-1 13
Fax +49 (0) 9 11. 58 85-2 13
alina.bartels@jlo.de

Return deadline
14.12.2016

Hall/Stand

Company

Street

Postcode, Town, Country

Tel

Fax

E-mail

Person to contact

Tel

Fax

Invoice address (only if different)

Application

VAT ID number of exhibitor:

Exhibition Insurance

Insured are exhibition goods, booth, booth equipment and personal effects of the staff for the duration of the trade fair, including transport to and from the exhibition site.

(For an insurance sum over EUR 50,000 please inquire)

Up to
EUR 10,000

EUR 60.90

Up to
EUR 25,000

EUR 144.70

Up to
EUR 50,000

EUR 274.10

Follow-up Liability Insurance for Major Losses

Insurance is provided within a mutual policy of NürnbergMesse and for all companies that have applied for cover. The period of cover is for the duration of the trade fair including the assembly and dismantling of the stand. Insurance coverage is valid in excess of an existing General Liability coverage of EUR 500,000 to be in force for the insured company (exhibitor). If there is not existing such General Liability coverage the EUR 500,000 shall be deemed to be a deductible.

in excess of EUR 500,001 up to EUR 15,000,000 combined for bodily injury and/or property damage

EUR 59.50

Personal Accident Insurance (Additional Cover)

Insurance is provided for accidents that the insured stand staff suffer during their stay in the Exhibition Center Nuremberg.

Insured Sums: EUR 10,000 in case of death
 EUR 25,000 in case of 100 % invalidity

Up to 2 Persons
 EUR 12.80

Up to 4 Persons
 EUR 21.70

Up to 10 Persons
 EUR 42.50

All the aforementioned premiums are inclusive of possible statutory insurance tax.

We have read and accept the conditions stated overleaf.

* If necessary, NürnbergMesse is entitled to have the service ordered provided by another ServicePartner. In this case, the customer will be notified of the other ServicePartner in good time.

With our authorized signature below, we acknowledge acceptance of all items of the General and Special Terms of Business of NürnbergMesse and the General Terms of Business and the Special Conditions for Services of the ServicePartner.

Place and date

Company stamp and authorized signature

Confirmation of Coverage

In the name of and on behalf of the insurer we hereby confirm insurance cover within the scope of the insurance policies applied for overleaf.

Insurance coverage takes effect as soon as the application form is received by NürnbergMesse or by J.L. Orth GmbH Insurance Broker, but not sooner than the risk begins, regardless of when the invoice is sent, provided the insurance premium is paid before the risk begins or alternatively immediately after receipt of the invoice.

J.L. Orth GmbH
Insurance Broker

Short Information

(Important – please read carefully!)

The following is only for information purposes and only summarizes the insurance cover and does not mirror the conditions, regulations and exclusions of the respective insurance policies. Decisive for the insurance cover are only the respective insurance policies and their conditions and regulations. These policies can be requested if wished by contacting J.L. Orth GmbH Insurance Broker on Tel +49(911)5885-0 or can be downloaded at www.nuernbergmesse.de/insurance.

Exhibition Insurance

Policy no. JLO-8194601

1. Purpose of the insurance

The Exhibition insurance is an All Risk cover and insures the exhibition goods, the stand and equipment including transport to and from the exhibition site, the building up of the stand for the duration of the trade fair and the dismantling of the stand. Personal effects of stand staff are insured only within the exhibition area against fire, burglary and proven theft

2. Insured Risks

The Exhibition insurance covers claims arising from damages that occur through loading and unloading, during transport or stopovers or for storage in-between or after the erection of the stand, and for damages that occur for the duration of the fair. Insured are those claims that result, for example, through

- a) conveyance accidents,
- b) fire, lightning or explosion,
- c) force majeure,
- d) burglary or theft,
- e) breakage or leakage of fluids,
- f) visitors at the trade fair.

The Exhibition insurance covers the costs for the expert restoration or repair or the value of the insured goods in case of a complete write-off.

3. Risks not insured

- Excluded from insurance cover are amongst others, claims
- a) arising through demonstrations, rehearsals, load tests and similar,
 - b) that the insured exhibitor brings about on his own goods, through such actions as assembly and dismantling,
 - c) arising through scratches and other polishing damage or gluing,
 - d) through theft, burglary or loss of food and groceries that were foreseen for consumption.

Not insured are: cash, documents, bonds, tickets and other valuables.

4. Requirements for insurance coverage

During the periods of assembly and dismantling of the stand, the exhibition goods, equipment and/or the stand **must be regularly controlled** by the stand staff or by a security guard or a trusted representative.

A police report must be prepared for damages caused through theft, burglary or robbery.

Liability Insurance for Major Losses

Policy no. JLO-8194308

1. Subject of Insurance

Insured is the policy holder's liability on the basis of legal provisions under Private Law in consequence of the policy holder's company characteristics and employees (stand staff) in regard to bodily injury and/or property damage.

2. Important Exclusions!

- Not insured are amongst others
- a) liability claims made that exceed the scope of legal liability,
 - b) damages suffered by the policy holder,
 - c) damages wilfully caused by the policy holder,
 - d) monetary fines,
 - e) damages occurring through usage of motor vehicles,
 - f) claims arising from non-fulfillment.

3. Limitations of Insurance

- a) The insurance sum (limit) is provided mutually for all companies included in the insurance policy.
- b) The insurance provides coverage in excess of an existing General Liability Insurance for the insured company with an insurance sum of at least EUR 500,000 combined for bodily injury and/or property damage.
- c) If there is no existing General Liability Insurance for the insured company then the EUR 500,000 shall be deemed to be a deductible.

Personal Accident Insurance

(Additional Cover)

Policy no. JLO-8194402

1. Scope of Cover

Insurance is provided for **accidents** suffered by the insured stand staff during their stay on the premises of the trade fair (including parking places) that result in a permanent physical or mental disability of the insured or the death of the insured person within one year after the accident.

An accident has occurred if, due to an external event, the insured person is suddenly bodily affected and involuntarily suffers an impairment of health.

2. Exclusions

The following are excluded from cover:

- a) accidents caused by mental impairment of consciousness, also such accidents that are attributable to drunkenness, as well as accidents caused by strokes, epileptic fits etc.,
- b) impairment of health caused by radiation,
- c) infections,
- d) poisoning,
- e) damage to vertebral discs.

Special Terms of Business for On-Site Advertising

As of December 2012

1. Scope

The General Terms of Business for Outdoor and Indoor Advertising are part of the contracts concluded between NürnbergMesse GmbH (hereinafter referred to as NürnbergMesse) and the exhibitor (hereinafter referred to as the customer) for the purpose of outdoor and indoor advertising or equivalent advertising measures. These terms apply exclusively **unless other arrangements have been agreed in writing**. Any of the customer's own General Terms of Business that deviate from these terms shall be ineffective.

2. Outdoor and indoor advertising

(1) Outdoor and indoor advertising outside the rented stand spaces in the Exhibition Center Nuremberg is subject to extra charges. Such advertising outside the rented stand spaces is permitted only for registered customers at the respective event, subject to the customer's prior receipt of written confirmation of the order for the intended advertising measures from NürnbergMesse.

(2) Outdoor or indoor advertising measures outside the customer's own rented stand spaces that are not permitted or approved will be removed and impounded by NürnbergMesse or its vicarious agents at the customer's cost.

(3) Outdoor advertising is advertising by customers in the form of various sizes of posters and banners in the outdoor area of NürnbergMesse during the booked event.

(4) Indoor advertising is advertising using posters or any kind of print or multimedia advertising on a wide range of carriers and in various sizes in the indoor area of the exhibition center during the booked event.

(5) These provisions shall apply analogously to any other kind of advertising measures on the exhibition site.

3. Orders/conclusion of contracts

(1) It is expressly stated that the Exhibitors Info Manual, any descriptions of advertising services or comparable printed information provided by NürnbergMesse do not represent an offer by NürnbergMesse and are not binding.

(2) The customer submits a binding offer on placing an order for advertising measures. This order **must** be made in writing. NürnbergMesse accepts such an offer by sending written confirmation of the order.

(3) All advertising spaces **are allocated in the order of receipt of the written orders**. The order must comply with any minimum order requirements.

(4) **The customer has no entitlement to a certain advertising space**. If the advertising space ordered is already booked, the customer will **therefore** be offered the next possible free advertising space at the discretion of NürnbergMesse. The customer expressly acknowledges his acceptance of this practice.

(5) NürnbergMesse may decline to accept orders for advertising received after the deadline.

(6) NürnbergMesse may employ external companies or subcontractors to provide the agreed services. NürnbergMesse will primarily appoint its service and contractual partners for this purpose, to which the customer may only object for good cause. Unless otherwise agreed, third parties shall be appointed on behalf of and to the account of NürnbergMesse.

4. Prices, payment terms, right of retention

(1) Unless otherwise agreed, the prices stated by NürnbergMesse are in euros without the statutory rate of value added tax.

(2) Special graphic work and production of films from clean drawings are charged separately. If the customer subsequently requests substantial changes to the originally agreed designs, he may be invoiced separately for the resulting additional costs.

(3) Invoices issued by NürnbergMesse are due for payment in full immediately on receipt.

(4) The customer shall only possess offsetting or retention rights if his counterclaims are legally effective or recognized by NürnbergMesse. Moreover, a right to retention exists only if the counterclaim asserted is based on the same contractual relationship as the claim of NürnbergMesse.

5. Deadlines

(1) The deadlines for sending print material or posters – **to be arranged by the customer** – are shown on the respective order forms or order confirmation documents.

(2) The customer is responsible for the timely delivery of the print material or posters.

(3) NürnbergMesse shall be liable for the timely completion and proper quality of the work only if the customer correctly fulfils his contractual obligations, in particular concerning the timely provision of documents and material.

(4) NürnbergMesse provides no guarantee and accepts no risk concerning obtaining the materials or ingredients necessary for creating the advertising. NürnbergMesse shall therefore only be liable in case of intention or gross negligence, provided such limitation is legally admissible and liability is not excluded in accordance with the following sections.

6. Responsibility for content

(1) The customer is responsible for the content of the advertising and any resulting damages and for the content and legal admissibility of the pictures and text material provided for the advertising medium. The customer assumes responsibility for ensuring that the outdoor or indoor advertising service ordered by him and executed according to information and documents provided by him does not violate any industrial property rights of third parties. NürnbergMesse is not obliged to check whether the information or documents supplied by the customer for performing the service violate or may violate the industrial property rights of third parties. Therefore, NürnbergMesse does not guarantee that information or documents not provided by NürnbergMesse are free from claims of third parties.

(2) NürnbergMesse reserves the right to reject advertising orders because of their content, origin or technical form based on standard, objectively justified reasons, if at the due discretion of NürnbergMesse their content violates laws or official regulations or offends against public morals. The rejection of an advertising order shall be notified to the customer without delay. NürnbergMesse also reserves the right to reject advertising orders because of their content and overall visual appearance for qualitative and aesthetic reasons, particularly in cases where their publication would be unreasonable for NürnbergMesse. Such rejection of an advertising order shall also be notified to the customer without delay. NürnbergMesse shall not be subject to liability for a rejected advertising order.

(3) The same applies and entitles NürnbergMesse to cancel a customer's advertising order without delay if NürnbergMesse does not become aware of the content and overall visual appearance of the advertising, its origin or technical form until after confirmation of the order. In this case, Sections 11. (2) and (3) apply accordingly.

(4) In the event of violation of his obligations in accordance with Paras. 1 – 3, the customer shall be obliged to exempt NürnbergMesse from all possible claims for damages by third parties immediately, to assume liability for all damages arising out of the violation of industrial property rights, and to render payments in advance if requested by NürnbergMesse.

7. Quality and transmission of print material

(1) The customer is responsible for providing faultless print material. Articles required by NürnbergMesse for providing the service must be delivered by the customer free house or to the destination stated by NürnbergMesse on the agreed date. If the customer requests the return of such articles, they will be returned from the place of use at the customer's cost and risk.

(2) NürnbergMesse shall keep the documents handed over by the customer for a period of one month after the end of the event. The customer agrees to make **prior** duplicate copies of any original materials (slides, disks, etc.) provided. NürnbergMesse accepts no liability for materials provided by the customer if the customer does not request their return within one month after the end of the event.

(3) A color proof is to be enclosed for color printing, otherwise no responsibility can be accepted for correct color reproduction. NürnbergMesse shall request replacement without delay if advertising documents are found to be unsuitable or damaged. NürnbergMesse guarantees the customary printing quality for poster and banner advertising within the scope of the print material provided.

(4) The customer shall bear additional costs or losses occurring during processing due to defects in the advertising material provided that were not immediately apparent but could only be detected during processing.

Special Terms of Business for On-Site Advertising

(continued)

8. Storage and return of advertising aids

(1) If the customer requests the return of such advertising aids within the period stated, they will be returned from the place of use at the customer's cost and risk.

(2) In the event of a clash of events, the customer is obliged to remove the advertising aids handed over at his own cost by not later than 06:00 on the day after the end of the event. NürnbergMesse shall inform the customer of any clash of events in good time.

(3) Paras. 1 and 3 apply analogously to advertising aids produced or commissioned for the customer by NürnbergMesse.

9. Guarantee and liability

(1) The customer is obliged to check the services provided by NürnbergMesse and to notify any defects without undue delay. If defects are revealed later despite careful examination, these shall be notified without undue delay after detection. NürnbergMesse must receive all notifications of defects by not later than seven days after the end of the event.

(2) If the notification of a defect is justified, NürnbergMesse shall provide a replacement or rectify the defect at its discretion. If remedial action fails to rectify the defect, the customer may withdraw from the contract or reduce the purchase price. After two unsuccessful attempts to rectify the defect, the remedial action is regarded as failed, unless the situation changes, in particular due to the nature of the matter or the defect or due to other circumstances.

(3) In addition, the customer may only claim damages instead of the service or repayment of expenses in the event of intention or gross negligence on the part of NürnbergMesse or its vicarious agents. This restriction shall not apply if NürnbergMesse or its vicarious agents are compulsorily legally liable due to the violation of an obligation decisive for the achievement of the overall purpose of the contract or liable due to damage to health, human injury or loss of life.

(4) The liability of NürnbergMesse is limited to the amount of the foreseeable typical damage for this type of contract, provided the damage has not been caused by intent or gross negligence or in the event of liability due to damage to health, human injury or loss of life.

(5) This shall not affect liability under the terms of the Product Liability Act.

(6) NürnbergMesse shall bear the costs of any necessary remedial action, particularly the cost of transport, travel, labor and materials. NürnbergMesse shall not be liable for other incidental expenses resulting from the notification of a defect, in particular the cost of indirect or consequential damages or losses, such as the loss of income, non-availability for use, capital costs or loss of profit.

(7) Guarantee claims against NürnbergMesse may only be asserted by the customer himself and are not transferable.

(8) All guarantee claims cease if the defect is notified late. The same applies if the customer makes changes himself or makes it impossible for NürnbergMesse to detect the defects.

10. Statutory limitation

(1) The customer's claims to remedial action, damages, repayment of expenses or price reduction due to a defect shall lapse by statutory limitation within a period of one year after acceptance of the service or, if acceptance is not possible due to the condition of the service, within one year after the end of the event. Withdrawal from the contract after expiry of the period of statutory limitation is null and void.

(2) Other claims of the customer shall also lapse by statutory limitation within a period of one year. The start of this period of statutory limitation is based on the legal regulations.

11. Cancellation of orders

(1) Cancellation of an advertising order must be made in writing.

(2) In the event of cancellation before the date of printing, NürnbergMesse shall be entitled to charge for the costs incurred up to this time. This also applies to claims for damages for loss of profit, provided the cancelled advertising space could not be sold elsewhere for the booked period despite appropriate efforts by NürnbergMesse.

(3) In the event of cancellation after the date of printing, the customer agrees to pay the full remuneration agreed.

12. Force majeure

Cases of force majeure, industrial action or other circumstances that are beyond the reasonable influence of NürnbergMesse and prevent it fulfilling its contractual obligations shall release NürnbergMesse from its obligation to fulfill orders and pay damages.

13. Contracts in electronic business

If the customer uses the Online Exhibitor Shop for the purpose of placing an advertising order or concluding any other service contract, NürnbergMesse shall only be obliged to ensure that the customer can access the General Terms of Business and save them in reproducible form at the time of concluding the contract. Further obligations of NürnbergMesse, especially in accordance with Art. 312 g Para. 1 p. 1 No. 1 – 3 BGB (German Civil Code) in conjunction with Art. 246 Section 3 of the Introductory Act to the German Civil Code and Art. 312 g Para. 1 p. 2 BGB, are excluded.

14. Place of performance and jurisdiction

(1) The place of performance and jurisdiction for all obligations arising out of the contract for outdoor and indoor advertising is Nuremberg, provided the customer is a merchant, a legal entity under public law or a special asset under public law, or has no general place of jurisdiction in the country.

(2) German law and the German text of these General Terms of Business shall prevail. This contract is exempt from the provisions of the UN sales law.

15. Data protection

Personal data are collected, processed and used by NürnbergMesse and, if applicable, by ServicePartners in accordance with the provisions of the German Federal Data Protection Act and other relevant data protection regulations for the purpose of providing support and information for customers and potential customers and for handling the services offered.

16. Consent to the use of data

The customer consents to the storage, processing and use of his data supplied with the order (company name, address, telephone/fax number and e-mail address) by NürnbergMesse and, if applicable, by ServicePartners for events and information purposes (advertising). This consent may be cancelled at any time by notifying NürnbergMesse, without incurring additional costs other than the usual transmission costs at the basic rates.

17. Separability clause

If a provision of these terms of contract or a provision as part of other agreements is or becomes void, this shall not affect the effectiveness of any remaining provisions or agreements or the contract between the parties. In this case, the customer together with NürnbergMesse shall replace the void provision by an effective one that represents the business purpose of the void provision as accurately as possible.

Contents

1	Introduction	2	4.9.4	Escape routes, stairs	10
1.1	Site regulations, extract from site regulations	2	4.9.5	Building materials	10
1.2	Opening times	2	4.9.6	Upper floor	10
1.2.1	Assembly and dismantling times	2	5.	Industrial safety, technical safety regulations, technical rules, technical supplies	10
1.2.2	Duration of event	2	5.1	General regulations	10
1.3	Responsible use of energy	2	5.1.1	Damage	10
2.	Traffic in the exhibition grounds, escape routes, safety equipment	2	5.2	Use of tools and equipment	10
2.1	Traffic regulations	2	5.3	Electrical installation	10
2.2	Escape routes	3	5.3.1	Connections	10
2.2.1	Fire brigade zones, hydrants	3	5.3.2	Stand installation	10
2.2.2	Emergency exits, escape hatches, hall gangways	3	5.3.3	Installation and operating regulations	11
2.3	Safety equipment	3	5.3.4	Safety measures	11
2.4	Stand numbering	3	5.3.5	Emergency lighting	11
2.5	Security	3	5.4	Water and waste water installation	11
2.6	Emergency evacuation	3	5.5	Compressed air and gas installation	11
3.	Technical details and equipment of halls and outdoor area	3	5.5.1	Compressed air	11
3.1	Hall details	3	5.5.1.1	Stand installations	11
3.1.1	General lighting, power supply, voltage	3	5.5.1.2	Installation and operating regulations	11
3.1.2	Compressed air, electricity and water supply	3	5.5.1.3	Compressed air cylinders	11
3.1.3	Communication facilities	4	5.5.1.4	Compressors	12
3.1.4	Sprinklers	4	5.5.2	Gas	12
3.1.5	Heating, ventilation	4	5.6	Machines, pressure vessels, exhaust gas systems	12
3.1.6	Failures	4	5.6.1	Machine noise	12
3.2	Outdoor area	4	5.6.2	Product safety	12
4.	Stand construction regulations	4	5.6.2.1	Safety devices	12
4.1	Stand safety	4	5.6.2.2	Inspection procedures	12
4.2	Approval of stand construction	4	5.6.2.3	Ban on operation	12
4.2.1	Inspection and acceptance of structures requiring approval	4	5.6.3	Pressure vessels	12
4.2.2	Vehicles and containers	4	5.6.3.1	Acceptance certificates	12
4.2.3	Modification of non-conforming components	4	5.6.3.2	Testing	12
4.2.4	Extent of liability	5	5.6.3.3	Rented equipment	12
4.3	Construction heights	5	5.6.3.4	Supervision	12
4.4	Fire prevention and safety regulations	5	5.6.4	Exhaust gases and vapors	12
4.4.1	Responsibilities	5	5.6.5	Exhaust gas systems	13
4.4.1.1	Stand construction and decoration materials	5	5.7	Use of compressed gases, liquid gases and combustible liquids	13
4.4.1.2	Exhibition of motor vehicles	5	5.7.1	Compressed and liquid gas systems	13
4.4.1.3	Explosive substances	5	5.7.1.1	Application to use compressed gas cylinders	13
4.4.1.4	Pyrotechnics	5	5.7.1.2	Use of liquid gas	13
4.4.1.5	Balloons and airborne objects	6	5.7.1.3	Installation and maintenance	13
4.4.1.6	Fog machines	6	5.7.2	Combustible liquids	13
4.4.1.7	Ashbins, ashtrays	6	5.7.2.1	Storage and use	13
4.4.1.8	Waste and recycling material containers	6	5.7.2.2	Required storage	13
4.4.1.9	Spray guns, solvents	6	5.7.2.3	Storage containers	13
4.4.1.10	Abrasive cutting and all other work using naked flame	6	5.7.2.4	Place of storage	13
4.4.1.11	Empty packaging	6	5.7.2.5	Conditions for operation	13
4.4.1.12	Fire extinguishers	6	5.7.2.6	Filling of liquids	13
4.4.1.13	Equipment and installations requiring registration, inspection and approval	6	5.7.2.7	Empty containers	13
4.4.2	Stand roofing	6	5.7.3	Fuel paste and other fuels	13
4.4.3	Glass and acrylic glass	7	5.8	Asbestos and other hazardous substances	13
4.4.4	Reception rooms and inner rooms	7	5.9	Performance areas	13
4.5	Exits, escape routes, doors	7	5.10	Radiation protection	13
4.5.1	Exits and escape routes	7	5.10.1	Radioactive substances	13
4.5.2	Doors in escape routes	7	5.10.2	X-ray systems and stray radiation sources	13
4.6	Platforms, ladders, stairs, catwalks	7	5.10.3	Laser systems	13
4.7	Stand design	7	5.11	High-frequency equipment, radio installations, electromagnetic compatibility and harmonics	14
4.7.1	Appearance	7	5.12	Cranes, forklift trucks, empty containers	14
4.7.2	Verification of rented area	8	5.12.1	Displaying heavy and bulky exhibits and machines	14
4.7.3	Interference with building fabric	8	5.13	Musical reproduction	14
4.7.4	Hall floors	8	5.14	Beverage dispensing systems	14
4.7.5	Suspending objects from hall ceilings	8	5.15	Food safety monitoring	14
4.7.5.1	Provision of suspension points	8	5.15.1	Requirements for stand/kitchen equipment	14
4.7.5.2	Attaching objects to suspension points	8	5.15.2	Cooking appliances and food preparation processes	15
4.7.5.3	Use of truss systems	9	5.15.3	Barbecuing	15
4.7.5.4	Use of lifting equipment	9	5.15.4	Drinking water	15
4.7.5.5	Electric hoists	9	6.	Environmental protection	15
4.7.5.6	Manual hoists	9	6.1	Waste management	15
4.7.6	Stand partition walls	9	6.1.1	Waste disposal	15
4.7.7	Advertising materials, presentations	9	6.1.2	Hazardous waste	15
4.7.8	Disabled access	9	6.1.3	External waste	15
4.8	Outdoor area	9	6.2	Water, waste water, soil protection	15
4.9	Two-storey stands	9	6.2.1	Oil and grease separators	15
4.9.1	Application	9	6.2.2	Cleaning, cleaning agents	15
4.9.2	Regulations on building over stand areas, safety clearances, height of rooms in stands	9	6.3	Environmental damage	15
4.9.3	Permissible loads/load assumptions	10			

1. Introduction

NürnbergMesse GmbH, hereinafter known as NürnbergMesse, has drawn up regulations for its events with the aim of providing all exhibitors/organizers with optimum facilities for presenting their exhibits and approaching their visitors and potential customers. These regulations are mandatory for all exhibitors and organizers. In the interest of our exhibitors and visitors, these regulations also include safety regulations, which are intended to ensure the highest degree of safety for the technical and design aspects of events. The building regulations, fire prevention regulations and other safety regulations have been agreed with the responsible departments of the Nuremberg authorities. NürnbergMesse reserves the right to check for compliance with these regulations. Compliance with the applicable statutory regulations is also compulsory.

The organization of an event/operation of an exhibition stand may be prohibited in the interest of all participants if any defects found have not been cleared by the start of the event. The right is reserved to impose further requirements regarding safety and stand construction if necessary. The order forms for services are usually sent with the confirmation of admission and must be completed and returned by the specified deadline, as NürnbergMesse cannot accept responsibility for correct and timely execution of orders received late.

NürnbergMesse also reserves the right to impose a surcharge on the price of orders received late, in accordance with details given in the Exhibitors Info Manual. If applicable, exhibitors may be sent additional circulars with information concerning the preparation and organization of the event. These Technical Regulations have been agreed between the following exhibition companies and are published in a standard layout:

Deutsche Messe AG, Hanover
 Koelnmesse GmbH, Cologne
 Leipziger Messe GmbH, Leipzig
 Messe Berlin GmbH, Berlin
 Messe Düsseldorf GmbH Düsseldorf
 Messe Frankfurt GmbH, Frankfurt
 Messe München GmbH, Munich
 Landesmesse Stuttgart GmbH
 NürnbergMesse GmbH, Nuremberg

Building law in Germany is governed by the law of the individual states. The respective implementation regulations may therefore vary for this reason and because of the different building situation that exists at the various other venues. NürnbergMesse also reserves the right to make changes. The German text is legally binding.

1.1 Site regulations, extract from site regulations

NürnbergMesse possesses the sole domiciliary rights to the rented object and site, provided the renter is not entitled to these rights by act of law. The justified interests of the renter shall be taken into account when exercising domiciliary rights.

- 1.1.1 The domiciliary rights with respect to the renter and all third parties shall be exercised by personnel appointed by NürnbergMesse, whose instructions must be complied with and who are to be granted access to the rented object at all times.
- 1.1.2 In the event of contravention of the site regulations or disruptive behaviour, NürnbergMesse has the right to expel the persons concerned from the exhibition grounds and from its own car parks, withdraw their entrance tickets without compensation and have their vehicles towed away at the owner's cost and risk.
- 1.1.3 NürnbergMesse has the right to check the storage compartments of vehicles and receptacles carried by persons, if required.
- 1.1.4 In case of theft of exhibits, the relevant person will be expelled from the site and the police informed. NürnbergMesse reserves the right to exercise its right to detain the relevant person on the exhibition grounds until the person's identity is established by the police.
- 1.1.5 Visitors to the event must leave the exhibition grounds at the end of the daily event times.
- 1.1.6 Compliance with instructions issued by the event director, event equipment director and security manager appointed by NürnbergMesse is compulsory. The same applies to instructions issued by the security authorities, such as the fire brigade and public order office.

1.2 Opening times

1.2.1 Assembly and dismantling times

Work can be carried out during the general assembly and dismantling times from 7:00 to 19:00, unless other times are published for specific events (Info 1). For reasons of general security in the exhibition grounds, the halls and the exhibition grounds in general remain closed outside these times. Vehicle access to the halls is permitted during assembly and dismantling. The times that ServicePartners are present on site may differ from the general assembly and dismantling periods.

1.2.2 Duration of event

For the duration of an event, the halls are open one hour prior to the official opening time and one hour after the official closing time, unless other times are published for specific events (Info 1). Exhibitors who for justified reasons need to work on their stands outside these times require special written permission from NürnbergMesse.

1.3 Responsible use of energy

Energy efficiency is a core value of NürnbergMesse. It is our declared objective to be at the forefront of European trade fair companies in respect of energy efficiency. This is why we are committed to making all necessary resources available to achieve this goal.

Our energy efficiency programmes have to be characterized by a holistic approach involving ongoing improvement, technical development and efficiency of resources. We are continuously reviewing, evaluating and if necessary improving our energy management. We undertake to adhere to all applicable statutory requirements. In addition, we are committed to preventing waste of energy wherever it occurs and at all times and to using the latest environmental, safety and energy-saving technology that is economically feasible.

What can the exhibitor do to help?

- Switch off the stand lighting if there is sufficient daylight or lighting in the exhibition hall.
- When leaving the stand in the evening make sure to switch off the lights.
- Switch off printers, copiers and computers and do not leave them in standby mode.
- Use energy-saving LED lamps and energy-saving equipment and appliances (e.g. fridge with energy efficiency rating A+++)
- Whenever possible, re-close hall doors and gates, or keep them closed (even in summer to save cooling energy).

2. Traffic in the exhibition grounds, escape routes, safety equipment

2.1 Traffic regulations

All rules concerning the regulation and direction of traffic and any instructions issued by security personnel are to be strictly observed. The provisions of the German Road Traffic Act apply accordingly throughout the exhibition grounds and on all car parks owned by NürnbergMesse. The speed limit within the exhibition grounds is 20 km/h. Vehicle access to the service areas between the halls is not permitted outside the straight lanes, as these areas have basements. Unlawfully parked vehicles, trailers, containers, boxes and empty receptacles of any kind will be removed at the owner's expense and risk. Any instructions issued by NürnbergMesse staff charged with directing and controlling traffic must be observed and relevant information heeded.

Traffic and parking regulations: Parking in the immediate vicinity of the halls and especially in the loading yards and in front of the exits is prohibited for all types of vehicles for the duration of the event. During the assembly and dismantling periods, vehicles may only stop for loading and unloading at the designated parking spots. Vehicle access to the inner yard is not possible at any time. To prevent possible hindrance to the fire service, vehicles are to be removed immediately on completion of this work and can be parked on the designated parking areas. Vehicle access to the loading yards during assembly and dismantling is only possible on payment of a deposit of EUR 100 (exception: trucks of 7.5 t or more during dismantling). The deposit will be refunded if the vehicle leaves the loading yard within

the time limits stated below. Time limits during assembly: 1 hour for loading and unloading cars and vehicles up to 2.8 t. 2 hours for loading and unloading vehicles over 2.8 t. Time limits during dismantling: Vehicle access to the loading yards on the last day of the event is not possible from 13:00 until approx. 1 hour after the end of the exhibition due to delivery of empty containers by the exhibition forwarding agents. Access is possible: 1 hour after the end of the exhibition for cars and vehicles up to 2.8 t. 2 hours after the end of the exhibition for vehicles of 2.8 t to 7.5 t. 3 hours after the end of the exhibition for vehicles of more than 7.5 t. Length of stay: 1 hour for loading and unloading cars and vehicles up to 2.8 t. 2 hours for loading and unloading vehicles from 2.8 t to 7.5 t. 3 hours (extension possible) for loading and unloading vehicles of more than 7.5 t. The exact access times may vary and are notified at the entrance gates.

2.2 Escape routes

2.2.1 Fire brigade zones, hydrants

Essential fire brigade access routes and unrestricted movement zones marked by no stopping signs must be kept free at all times. Vehicles and objects parked on rescue routes and safety zones may be removed at the owner's cost and risk.

The marked fire-fighting equipment in the halls and outside area are not to be obstructed, obscured or made inaccessible. Wall hydrants are not to be used for filling purposes (e.g. containers, basins etc.).

2.2.2 Emergency exits, escape hatches, hall gangways

The escape and emergency routes are to be kept free at all times (see 2.6). Any doors located in escape and emergency routes must be easy to open from the inside over their full width. Escape and emergency routes, exit doors and emergency hatches and their identification markings must not be obstructed, built over, blocked, covered by hangings or rendered unrecognizable.

At no time may the gangways in the halls be restricted by objects placed in or projecting into them. Such gangways serve as escape routes in emergencies!

In the event of contravention NürnbergMesse reserves the right to re-establish the original conditions at the expense and risk of those responsible for the infringement.

Materials required for stand construction or exhibits delivered for immediate display in the stand space may be placed in the periphery of the hall gangway for a short time during the assembly and dismantling phases, provided the gangway widths required for safety reasons are still maintained and logistical interests are sufficiently taken into account. This requirement is regarded as fulfilled if the materials or exhibits are placed in a strip of maximum 0.90 m along the edge of the stand facing the hall gangway. Irrespective of the width of the hall gangway and the goods placed in the gangway, a minimum width of 1.20 m must be kept free for access. The areas in front of emergency exits and the junction areas of the hall gangways are to be kept clear of obstructions over their full width at all times. The hall gangways must not be used to set up assembly areas or machinery (e.g. woodworking machinery, workbenches etc.). The exhibition company may request immediate clearance of all hall gangways for reasons of logistics.

2.3 Safety equipment

Sprinklers, push-button fire alarms, fire extinguishing equipment, above-ground, underground or wall hydrants, smoke alarms, fire doors and self-closing doors and gates and other safety equipment, their markings and the green emergency exit signs must be accessible and visible at all times and must not be obstructed or made inaccessible. Exceptions are subject to approval and applications must be sent to NürnbergMesse (Exhibition Technology Departement, for contact details see 4.2) by the specified deadline (see 4.2).

2.4 Stand numbering

All stands will be marked with a stand number by the organizer if technically possible.

2.5 Security

The general supervision of the halls and outdoor area for the duration of the exhibition is provided by NürnbergMesse. General supervision is also provided during assembly and dismantling times. NürnbergMesse is authorized to carry out the necessary control and security measures.

If a stand security guard is required, this must be ordered by the exhibitor himself using the Online ExhibitorShop (OES). Stand guards may only be provided by the security company appointed by NürnbergMesse.

Prevention of theft:

Incidences of theft in the Exhibition Center Nuremberg are comparatively rare. A continuing need to promote theft prevention measures is necessary to maintain this good reputation. This is achieved by NürnbergMesse through security control and guarding measures. These do not, however, apply to individual stands. Access to the halls during assembly and dismantling times is only permitted on display of special passes. Please support our efforts by observing the following instructions:

1. Assembly: Your stand should not be left unsupervised after exhibits have been delivered following stand assembly. Although halls are locked and guarded on completion of assembly, an additional stand guard is generally recommended, also for the nights during the event. You should certainly lock away valuable goods at night. Safes and lockable display cases can be rented from the ServicePartners. Your stand cubicle can also be supplied with a lockable door (to be ordered on the relevant forms).

2. Dismantling: Do not leave your stand until valuable exhibits have been loaded or handed over to the forwarding agent. Should this not be possible for special reasons, please order a stand guard for the time between the end of the event and the start of dismantling your stand. The organizer carries out random checks of persons dismantling stands. You should therefore issue staff responsible for dismantling your stand with a certificate indicating the stand to be dismantled.

3. Opening times: Most thefts occur during opening times. Never leave your stand unattended, not even during the lunch period. Personal articles should be locked away. Especially exhibits liable to theft should be secured, e.g. with thin chains, nylon threads or presented in lockable display cases. The exhibition team and Exhibition Services Team will be pleased to advise on theft prevention matters. NürnbergMesse reserves the right to impose special theft prevention conditions on individual exhibitors. Please also check your insurance against theft. We recommend taking out an exhibition insurance policy. NürnbergMesse appreciates your cooperation.

2.6 Emergency evacuation

NürnbergMesse or the responsible authorities may order the closure and evacuation of rooms or buildings for safety reasons. Persons present in these rooms or buildings must comply with this request and evacuate the rooms or buildings via the marked emergency exits. Exhibitors must inform their staff of this procedure or if applicable draw up their own evacuation plans and display these on their stand.

3. Technical details and equipment of halls and outdoor area

3.1 Hall details

see Instruction Sheet i4.1 "Technical data of halls", and the permissible point loads.

3.1.1 General lighting, power supply, voltage

The general lighting in the halls is 350 – 400 lux measured 1 m above the hall floor; power supply 230 V – 400 V up to 125 A. Higher ratings and special variants are possible on request.

Connections up to 63 Amp are protected by Residual Current Devices (RCD). Tolerances to DIN EN 50160.

3.1.2 Compressed air, electricity and water supply

Compressed air, electricity and water for stands are supplied in halls 1 – 12, 3A, 4A and 7A.

3.1.3 Communication facilities

Telephone, fax, data and antenna connections to the stands in all halls are ordered from the responsible ServicePartner (for further guidelines and conditions see Telecommunications in the Online ExhibitorShop (OES). Exhibitors may only set up a WLAN (Wireless Local Area Network) if this has been expressly approved in writing by the Exhibition Services Department (for further guidelines and conditions see Telecommunications in the Online ExhibitorShop (OES).

3.1.4 Sprinklers

With the **exception** of halls **4A** and **7A**, halls 1 – 12 and 3A are equipped with sprinkler systems. These must have a safety clearance > 1.00 m at the top edge of the stand for fire prevention and insurance reasons. The minimum safety clearance in closed rooms (e.g. conference rooms) is 0.70 m. Smaller clearances must be approved by NürnbergMesse (Exhibition Technology Department, for contact details see 4.2).

3.1.5 Heating, ventilation

Heating and ventilation are available in all halls.

3.1.6 Failures

Any failures in technical supplies are to be notified to the exhibition team without delay. NürnbergMesse shall not be liable for any losses or damage caused by such failures and due to ordinary negligence.

3.2 Outdoor area

The following general provisions (4. Stand construction regulations) shall also apply by analogy for stands erected outdoors.

Stands, structures and special structures (e.g. tents/marquees, stages, show trucks) outdoors must be submitted to NürnbergMesse (Exhibition Technology Department) for approval in good time (see 4.2).

An approved or verifiable structural analysis, true-to-scale floor plans and elevation drawings must be submitted. If the structures outdoors are classified as temporary structures a valid approval (as per accompanying structural specifications [Baubuch]) must be available and the exhibitor/responsible entity must notify the relevant authorities accordingly at least four weeks before erecting the structure.

A copy of the notification to the relevant authority must be submitted to NürnbergMesse by the latest two weeks before the start of the event.

In the event of queries please contact the building inspectorate:

Bauaufsicht Süd
Bauhof 5
90402 Nürnberg
Tel +49 (0) 9 11. 2 31-43 71

The costs for the necessary approval of the temporary structure by the relevant authority will be billed to the exhibitor/stand builder. Generally, excavations and ground anchoring (e.g. ground stakes) are not admissible outdoors.

If you do not comply with these stipulations you will generally be responsible for all loss and consequences in the event of damage to piping and cables (even if you have received special permission from NürnbergMesse). All material brought to the outdoor area must be removed and the area restored to its original state.

4. Stand construction regulations

4.1 Stand safety

Stands, including all equipment, exhibits and advertising media, are to be constructed with such stability as to pose no danger to public safety and order, especially to life and health.

The exhibitor is responsible for structural safety and must provide proof of this if necessary. Standing construction elements or special constructions (e.g. free-standing walls, tall exhibits and tall decorative elements) that may tip over must be loaded with a minimum

horizontal equivalent distributed load of q_h :

- $q_{h1} = 0.125 \text{ kN/m}^2$ ($0 < h < 4.0 \text{ m}$)
- $q_{h2} = 0.063 \text{ kN/m}^2$ ($h > 4.0 \text{ m}$)

The reference area here is the respective face area.

The certificates issued for this purpose (verifiable structural analyses) are to be submitted at the request of NürnbergMesse.

In justified cases, NürnbergMesse reserves the right to have the stand safety checked on site by a structural engineer at extra cost. Stabilizing against neighboring stands or existing structures is not permissible.

4.2 Approval of stand construction

Assuming that the technical regulations of the respective event (see Info 1) have been observed in the design and construction of the stand, it is still necessary to submit drawings for approval in respect of single storey stand structures with a height of 3.50 m or more.

NürnbergMesse is prepared to check the stand construction drawings submitted if requested by the exhibitor.

Furthermore, all other stand structures, mobile stands, special structures, etc. are subject to approval. See 4.2.3.

For technical approval procedures please contact NürnbergMesse: Exhibition Technology Department
veranstaltungstechnik@nuernbergmesse.de

Time period for approval process:

Especially in the case of complicated approval processes, e.g. including additional official approval or inspections, please allow a processing time of up to six weeks after the complete documentation has been submitted to NürnbergMesse Processing within two weeks is only possible in exceptional cases providing we have the complete documentation and there is little complexity involved. The period specified applies to the issue of the approval and does not represent the event date. In the following paragraphs we use the phrase "by the specified deadline".

Definition of "approved":

Even if approval has been given by NürnbergMesse, this does not exempt you in principle from adhering to the Technical Regulations, unless a departure from the Technical Regulations was specifically part of the approval process.

4.2.1 Inspection and acceptance of structures requiring approval

Dimensioned stand plans to a scale of not less than 1:50 with layout plans, views and if necessary seating plans must be submitted to NürnbergMesse by the specified deadline (see 4.2). The stand construction is not permitted until the plans have been stamped as authorized.

For approval of:

- two-storey stand structures
- outdoor buildings (temporary structures)
- special constructions
- cinemas or lecture rooms larger than 100 m²
- performance/stage area
- podium areas and walkable structures from a height of 0.20 m

The following documents must be submitted in German (in duplicate) by the specified deadline (see 4.2):

- a) Structural analysis to German standards
- b) Building specification with details of materials to be used
- c) Items a) and b) are not required if a valid site inspection log/type test is submitted
- d) Seating plans, if applicable escape and emergency route plan (cinema and lecture rooms)
- e) Escape route plan with evidence of lengths and widths of emergency routes.

The cost of the approval procedure will be charged to the exhibitor/stand construction company.

4.2.2 Vehicles and containers

Vehicles and containers used as exhibition stands in the halls and throughout the exhibition grounds and car parks are subject to approval.

4.2.3 Modification of non-conforming components

Stand structures that are not approved and/or do not conform to the technical regulations or the law must be modified or removed by the exhibitor/stand builder if necessary.

If this is not done within the specified deadline, NürnbergMesse is entitled to have the changes made at the expense of the exhibitor.

4.2.4 Extent of liability

No claims for damages whatsoever due to negligent action or failure on the part of NürnbergMesse or its subcontractors and ServicePartners will be entertained by NürnbergMesse in respect of loss, damage or impairment of any kind suffered by designs, models or documents submitted, irrespective of the legal basis for such claims.

4.3 Construction heights

The construction heights for specific events are shown in the application documents and in Info 1.

4.4 Fire prevention and safety regulations

4.4.1 Responsibilities

The Nuremberg Public Affairs Office (Ordnungsamt) is responsible for events governed by the Trade Regulations. The technical acceptance of the event is carried out by a representative of the Nuremberg fire brigade, a representative of the Public Affairs Office and a representative of the operator (person responsible for event technology) and if necessary a representative of the organizer.

In all cases of doubt concerning fire prevention matters, exhibitors are recommended to contact the Exhibition Technology Department (see contact details in 4.2).

The trade inspectorate and regulatory authorities, police, fire brigade, the event director or the event equipment director of NürnbergMesse and representatives of NürnbergMesse (Exhibition Technology Department) and the organizer's representatives are entitled to issue instructions as part of safety regulations. Their representatives are to be granted access to the safety equipment and technical facilities at all times.

4.4.1.1 Stand construction and decoration materials

All stand construction and decoration materials must conform as a minimum to **B1** as per DIN 4102 or **class B/C s2d0** as per EN 13501-1, i.e. they must have low flammability. The use of materials such as polystyrene, PVC or similar materials that are easily ignited, drip on burning (see Instruction Sheet i4.4 "Building Material Classes") or form toxic gases or large amounts of smoke is prohibited. For safety reasons, load-bearing construction elements may be required to meet special requirements in individual cases (e.g. non-combustible). Decoration materials must at least comply with Section B1 of DIN 4102 or at least Class C of EN 13501-1, i.e. difficult to ignite. A test certificate documenting the building material classes and required properties of the material must be carried at the stand even during assembly and must be kept available for inspection. Decoration materials with a normal combustibility rating may be used in certain areas if the method of installation (e.g. display cabinets) provides adequate protection against catching fire. Sprinkler-compatible decoration materials are allowed for ceilings. A current VdS test certificate confirming the class of building product and sprinkler compatibility of the material used must be available for inspection on the stand during assembly (see Instruction Sheet "Installation of sprinkler-compatible ceiling fabrics"). Cuttings of trees and plants may only be used for decoration purposes in a green condition. Should they dry out during the event and become easily ignited (DIN 4102 B3), they must be removed. Trees should be free of branches up to approx. 0.50 m above floor level. The use of deciduous and coniferous trees is permitted only if they have moist, potted roots. Bamboo, reeds, hay, straw, bark mulch, wood chips or similar materials do not meet adequately meet the above-mentioned requirements and are therefore not permitted. Absorbent natural materials in natural fibers such as jute bags, woven and knitted fabrics or similar do not generally have "low flammability" and may only be used if treated with a suitable flame retardant impregnation.

Construction and decoration materials such as wooden pallets, boxes or baskets whose design and surface properties represent a high fire load are generally not admissible. Any fire protection measures such as treating the surfaces and additional fire-proof coatings must be registered and agreed on beforehand with the Exhibition Technology Department using **Form P2**.

"Flame resistant" properties can be achieved retrospectively for some of these materials by treating them with an approved flame inhibiting agent. A certificate confirming that the material is flame resistant or that impregnation has been carried out in accordance with the regulations must be available for inspection on the stand at all times.

Flame-inhibiting impregnation of materials can be ordered from our ServicePartner Messebau Wörnlein GmbH or another qualified service provider.

Flame-inhibiting impregnation:

Messebau Wörnlein GmbH
Messezentrum 1
90471 Nürnberg
Tel +49 (0) 9 11. 81 74 49-0
Fax +49 (0) 9 11. 81 74 49-25
info@woernlein.de

Liability can only be accepted for impregnation if the material to be impregnated is an absorbent natural fiber.

Structurally essential fixings may only be carried out using the fixing items approved for them (e.g. cable ties are not permitted).

4.4.1.2 Exhibition of motor vehicles

The exhibition of vehicles must be notified to NürnbergMesse (Exhibition Technology Department) using **Form P2**, stating the number and type of vehicles involved.

For all vehicle types a sufficient number of suitable hand-held fire extinguishers (to EN 3) must be kept in readiness at the exhibition stand. NürnbergMesse GmbH reserves the right to take additional measures.

Vehicles with internal combustion engines

The content of vehicle fuel tanks is to be reduced to the amount necessary for driving into and out of the hall (the low fuel warning lamp must be on); the tank cap is to be locked. Powering the vehicles via the starter battery is possible if it can be ensured that no dangerous gases will be produced (e.g. in the case of gel batteries if the contacts are shockproof and the starter motor is permanently isolated from the battery).

Further safety measures such as inertization of the fuel tank, disconnecting the battery and/or posting security guards may be necessary, depending on the event and the vehicle location (e.g. foyer areas, entrances, fire brigade access roads or assembly rooms).

Vehicles with electric or hybrid motors

In the case of hybrid vehicles the tank must also be largely empty and closed. In vehicles with electric motors, the drive batteries are to be disconnected from the transmission at the safety switch (main switch). High-voltage batteries have to be disconnected and in a non-critical state.

Vehicles with gas-powered engines

In gas-powered vehicles, the pressure vessel must be empty as far as possible. Care should be taken to ensure that a low residual pressure remains in the vessel so that there is no danger of explosive gases forming if air penetrates (see 5.7).

Vehicles with fuel cells or alternative drives

Vehicles with fuel cells or other types of drive are considered separately.

However, it should generally be noted that the tank content must be reduced to the amount necessary to drive in and out (the reserve light on the tank display must be on).

4.4.1.3 Explosive substances

Explosive substances are governed by the German Explosives Act and may not be exhibited at trade fairs and exhibitions.

4.4.1.4 Pyrotechnics

Pyrotechnic demonstrations require approval and must be coordinated with NürnbergMesse (Exhibition Technology Department, contact details in 4.2). If pyrotechnic effects are to be used on the NürnbergMesse grounds, the exhibitor/organizer must obtain approval from the responsible Public Order Office, the Trade Inspectorate and the Nuremberg fire brigade not later than 4 weeks before the actual date of the event. A copy of the

approved application is to be submitted to NürnbergMesse by not later than 2 weeks before the start of the event. The license for the articles is shown on the respective packing unit. Instructions must also be printed on the package in German. Pyrotechnic objects without approval or pyrotechnic objects in Class II, III or IV are not approved. Proof of the holder of the license and certificate of competence is to be submitted to NürnbergMesse (see Instruction Sheet i4.5 "Pyrotechnic displays/activities involving fire hazards").

4.4.1.5 **Balloons and airborne objects**

The use of balloons filled with safe inert gas in the halls and outdoor area must be approved by NürnbergMesse. The use of airborne objects (e.g. drones, helicopters) in the halls and outdoor area of NürnbergMesse is generally prohibited. Any exceptions must be authorized and notified in writing by the specified deadline (see 4.2) before operation to the Exhibition Technology Department (for contact details see 4.2).

4.4.1.6 **Fog machines**

The use of fog machines or hazers is subject to arrangement with NürnbergMesse (Exhibition Technology Department). NürnbergMesse will charge the organizer or responsible entity for the cost of substitute measures if firefighting appliances must be deactivated before operating a fog machine. The organizer and/or person responsible will be charged for the cost of calling out the fire brigade if the fire alarm system is set off without prior consultation with NürnbergMesse. Further information can be obtained from Instruction Sheet i4.6 "Use of fog machines".

4.4.1.7 **Ashbins, ashtrays**

There is a total smoking ban in the halls, stands and empty areas during assembly, dismantling and the trade fair itself. If the smoking ban has been lifted for the stand or parts of the stand (does not apply to assembly and dismantling), an adequate number of ash bins or ashtrays of non-combustible material must be provided and emptied at regular intervals.

4.4.1.8 **Waste and recycling material containers**

Bins provided on the stands for waste and recyclable materials are to be made of non-combustible materials only. These bins are to be emptied regularly and not later than every evening after closing time. Should larger quantities of combustible materials accumulate, these are to be disposed of several times a day. Waste disposal can be ordered at extra cost from the ServicePartners of NürnbergMesse using the Online ExhibitorShop (OES).

4.4.1.9 **Spray guns, solvents**

The use of spray guns and substances and paints containing solvents is prohibited in all halls.

The use of

- combustible liquids
 - materials releasing toxic vapors and
 - substances hazardous to the environment
- is prohibited.

4.4.1.10 **Abrasive cutting and all other work using naked flame**

All welding, cutting, soldering, thawing and abrasive cutting work must be notified to NürnbergMesse in writing for approval before commencement of the work. The approval of this work is granted by NürnbergMesse (Exhibition Technology Department (for contact details see 4.2) in the form of a permit for work involving dust, smoke, welding and heat. The adjacent area is to be adequately protected from hazards during this work. Suitable fire extinguishers and VDS approved fire blankets must be available for use in the direct vicinity. In addition, a fire safety guard can be arranged at extra cost via the Service-CD or online exhibitor shop. Due to the particular risk potential during assembly and dismantling, we recommend designing your stand so that such hazardous work is avoided or can at least be done outside the hall. The authorization can only be issued on time if the relevant application is submitted in good time to the Exhibition Technology Department (for contact details see 4.2).

4.4.1.11 **Empty packaging**

The storage of empty packaging of any kind (e.g. packaging and packing materials) inside or outside the stand, in the halls or in the loading yards is not permitted during assembly and dismantling or during the exhibition itself. Empty packaging is to be removed without delay. Collection and storage can be ordered at extra cost from the ServicePartners of NürnbergMesse using the Online ExhibitorShop (OES).

If the exhibitor does not comply with a request to remove material stored in contravention of the rules or does not remove empty packaging immediately when asked, NürnbergMesse reserves the right to have it removed at the cost and risk of the exhibitor.

4.4.1.12 **Fire extinguishers**

We recommend that at least one fire extinguisher to DIN EN 3 (see Instruction Sheet i4.7 "Fire extinguishers") is available on each stand. Only water or foam extinguishers with an up-to-date test label may be used. Powder extinguishers are only admissible for demonstrations using combustible gases.

It is recommended that, as far as possible, a water or foam extinguisher be used, since if a powder extinguisher is used, there is a risk that adjoining stands may need to be cleaned afterwards as the emerging jet of powder cannot be controlled. These costs will be charged to the party causing the need for cleaning. A fire extinguisher must be available for electrical distribution boxes with a total power rating of 6 kW and up. The size of fire extinguishers is limited to max. 12 kg. Suitable fire extinguishers (kitchens: Class A, B, F, storage areas Class A, B) are to be available at stands with kitchens and storage areas. Suitable tested fire extinguishers can be rented via our ServicePartner Wörnlein (**see 4.4.1.1**). NürnbergMesse reserves the right to charge for used or damaged fire extinguishers taken from wall hydrants.

4.4.1.13 **Equipment and installations requiring registration, inspection and approval**

Demonstrations using naked flames and associated with a considerable level of heat are subject to approval by NürnbergMesse (Exhibition Technology Department, for contact details see 4.2). We will then coordinate the necessary protective measures with the Nuremberg Fire Service. Such activities include lighting candles and demonstrations of non-electrically powered cooking, grilling, baking and heating appliances. Such actions involving fire hazards must be registered by submitting **Form P2** to the Exhibition Technology Department of NürnbergMesse. The use of liquid gas for such demonstrations is restricted to the usual daily amounts (**see 5.5.1.5**). The same applies to non-electrically powered appliances used for the stand's own supply purposes.

Oil-fired equipment and oil burners are governed by the relevant regulations of the Health & Safety at Work Act. Smoke, exhaust gases and vapors produced during the exhibition must be discharged outside the hall. This work is only to be undertaken by the relevant ServicePartner of NürnbergMesse. Kerosene, gasoline etc. are not to be used for cooking, heating or operating purposes or stored due to their easy inflammability. Please use **Form P2** to register such demonstrations or fuels. Failure to register causes additional work for which you will be billed.

4.4.2 **Stand roofing**

The ceilings of all stands in halls equipped with sprinklers must be of open design to avoid impairing the operation of the sprinklers. Ceilings are regarded as open if not more than 30 % (CEA 4001 S) of each square meter of the ceiling area is closed. This also applies to conference rooms, catering areas and reception rooms. The closed area of single-storey stands is not to exceed 30 m². For closed areas larger than 30 m², a suitable number of sprinklers and, in smoke-monitored halls, differential heat detectors must be installed by the responsible ServicePartner. Exceptions are possible in individual cases. Several ceiling areas up to 30 m² in one exhibition stand are possible, provided that there is a minimum distance of 3.00 m between the individual ceiling areas. So as not to exceed the maximum surface area of 30 m² when adding up

several ceiling areas, a distance of minimum 1.50 m to the stand limits must be observed. Any reduction of the 1.50 m distance (e.g. to passageways) has to be authorized by the Exhibition Technology Department (for contact details see 4.2).

The ceiling areas must be made of materials that do not drip on burning and conform to at least building product class DIN 4102 (B1) or DIN EN 13501 B-C or of components that are at least fire-retardant (see Instruction Sheet i4.4 "Fire prevention – European classification of building products").

All kitchens and stores must have open ceilings. In exceptional cases, sprinklers, and in smoke-monitored halls VDS-certified differential heat detectors, must be installed by the responsible Service-Partner. Sprinkler-compatible ceiling materials with a current VDS test certificate are admissible.

Installation must be in accordance with VDS. The test certificate on sprinkler compatibility and building material class of the material used must be kept at the stand for inspection during assembly. The fabric covering is to be of 1 layer only and braced horizontally. The fabric covering must not sag (**for two-storey stands see Item 4.9.2 and Instruction Sheet i4.2 "Installation of sprinkler-compatible ceiling materials"**).

4.4.3 **Glass and acrylic glass**

Only safety glass suitable for the intended purpose may be used. The edges of glass sheets must be finished or protected to reliably prevent risk of injury. Stand components made of glass only are to be marked at eye level.

Wall panels or supports in glass have to be designed to be load-free, i.e. roof structures or similar projecting elements have to be supported on beams or walls and structurally stable, without the loads being carried by glass panes or supports used (including glass cabinets).

Acrylic glass must at least meet the requirements of DIN 4102, B1 or DIN EN 13501, Bs2d0 or Cs2d0 and must not drip on burning (see Instruction Sheet i4.8 "Glass and acrylic glass"). In addition, the acrylic glass must generate minimal smoke (s1 or s2 to DIN EN 13501). Acrylic glass with no limitation of smoke production (s3 to DIN 13501) may only be used in exceptional cases following consultation with NürnbergMesse (Exhibition Technology Department, for contact details see 4.2).

4.4.4 **Reception rooms and inner rooms**

All reception rooms, lecture rooms, etc. that are closed on all sides (closed rooms) and have no visual or acoustic contact with the hall must be equipped with a visual and acoustic alarm system to ensure that an alarm can be sounded on the stand at any time. This also includes display areas without a clear view of the hall in some parts due to structures or exhibits.

Cubicles, conference rooms, offices and similar "closed" rooms must have a line of sight into the hall via the exhibition stand.

The visual contact should be designed so that when anyone is in the enclosed room they still have an unobstructed view when sitting or standing. A window 0.20 m wide and 0.80 m high is recommended as a suitable size for the field of vision.

If it is not possible to see the hall via the stand (because the view is blocked by structures, etc.), technical measures must be taken to compensate for this.

Such measures are subject to approval and must be notified in advance to the Exhibition Technology Department at NürnbergMesse (for contact details see 4.2).

Lecture rooms etc. with a **floor space exceeding 100 m²** require special approval. Seating is to be provided in accordance with § 10 of the Venue Regulations (VStättV) and drawn into an escape and emergency route plan in accordance with § 32.

Inner rooms (rooms that can only be left via other rooms) are not permitted.

4.5 **Exits, escape routes, doors**

4.5.1 **Exits and escape routes**

The distance from any point on a stand space to a necessary hall gangway must not exceed 20 m walking distance (§7 VStättV). This also applies to a two-storey stand.

Reception rooms with a floor space exceeding 100 m² must have at least two exits to escape routes and these must be positioned opposite each other and as far apart as possible.

The following minimum number and inside widths of escape routes (exits, stairs and corridors) are to be provided:

- up to 100 m² room area and less than 200 people
1 escape route, 0.90 m wide
- over 100 m² room area and less than 200 people
2 escape routes, each 0.90 m wide
- more than 100 m² room area and more than 200 people:
at least 2 escape routes each 1.20 m wide

The escape routes are to be marked as per ASR 2.3 (German Workplace Regulations).

It must be possible to open the doors of these exits from the inside in the escape direction at all times during the event and these doors must not protrude into the hall gangway. A suitable recess must be provided in all cases.

4.5.2 **Doors in escape routes**

The use of swing doors, revolving doors, doors with code locks, sliding doors and other access barriers in escape routes is possible subject to approval of escape routes by the building authority. Stand escape doors that open to the outside must not impair or restrict escape routes and hall gangways. A recess is to be provided.

4.6 **Platforms, ladders, stairs, catwalks**

Areas generally accessible to pedestrian traffic and directly adjacent to areas 0.20 m lower are to be enclosed by barriers. Barriers, such as protection devices and railings, must have a minimum height of 1.10 m. They must consist of at least a top band, centre band and bottom section. Safety devices must be suitably designed to prevent the risk of objects being placed on them and falling into areas below. If children are expected to be present in the area to be secured, the separation between the parts of the railings must not exceed 0.12 m in any direction.

For platforms, a verifiable structural analysis with load capacities to DIN EN 1991-1-1/NA:2010-12 Table 6.1DE [Cat. C] is to be provided as detailed below and submitted to NürnbergMesse by the specified deadline (see 4.2):

q_k ≥ 3.0 kN/m² Perpendicular load for limited use by trade fair visitors.

q_k ≥ 5.0 kN/m Perpendicular load for freely accessible areas and/or unrestricted use.

q_k = 1.0 kN/m Horizontal load at rail height.

Costs will be incurred for the inspection and approval of this special structure and will be billed to the exhibitor/stand builder. Accessible single-level platforms must not be higher than 0.20 m. The area underneath platforms and podiums must not be used for storage. They must be designed to be fire load free. Hollow spaces of platforms with a height of less than 0.20 m, can be excepted from monitoring by the fire alarm system. Hollow spaces of platforms with a height of more than 0.20 m, which accommodate an automatic turntable, or an accumulation of cables and/or electrical distributors, must be monitored by VDS certified smoke detectors. Installation must be done by the NürnbergMesse ServicePartner. Moving parts such as escalators or revolving stages are subject to the prior approval of NürnbergMesse, Exhibition Technology Department (for contact details see 4.2).

Stairs 1.20 m wide have to have handrails on both sides. Stairs more than 2.40 m wide need central handrails.

Ladders, stairs and catwalks must conform to the accident prevention regulations (German DGUV Information 208-016), formerly BGI 694).

4.7 **Stand design**

4.7.1 **Appearance**

The exhibitor is responsible for the design of the stand, which must be in keeping with the typical exhibition criteria for the event. Walls bordering visitor gangways should be made more attractive by installing glass showcases, niches, displays, etc. Rear walls of stands that exceed a height of 2.50 m and are adjacent to neighboring stands should have a light, neutral and single color to avoid adversely affecting the design of the neighboring stand. The use of products made by exploitative child labor within the meaning of ILO Convention 182 is prohibited for stand design and equipment.

4.7.2 Verification of rented area

The rented area is marked out by NürnbergMesse. Every exhibitor is obliged to obtain information about the location, dimensions and possible structures in this area by visiting the site. The stand limits must be strictly observed. The exhibitor must expect minor deviations in the size of the stand. These are due to variations in the thickness of the stand partition walls and may be up to 5 cm in front and depth. The corners are marked. No responsibility can be accepted for the correctness of the dimensions. The supply points inside the stand space must remain accessible. Any pillars, wall projections, stand partition walls and fire-fighting equipment are part of the allocated stand space.

The supply grid for electricity, compressed air, water and telecommunications is shown on the hall plans sent to exhibitors. The supply ducts are not to be opened by exhibitors or obstructed by stand structures.

The stand boundaries must be adhered to. Lighting fixtures or signs must not project out into the halls from the stand boundaries.

4.7.3 Interference with building fabric

Hall parts and technical equipment must not be damaged, soiled or altered in any other way (e.g. drilling, nails, screws). Painting, wallpapering and the use of adhesives are also prohibited. Floor coverings in the stands may only be fixed with double-sided adhesive tape (solvent-free adhesive tape only, e.g. tesafix No. 4964). Any costs caused by failure to comply will be charged to the exhibitor.

Hall parts and technical equipment must not be used to support loads from stand structures or exhibits.

However, hall pillars and supports inside the stand space can be adapted provided they are not damaged and the permissible construction height is not exceeded.

Installations on the hall pillars, walls and technical equipment must be freely accessible. If necessary inspection ports must be provided by the exhibitor building the stand.

4.7.4 Hall floors

Carpets and other floor coverings are to be laid so as not to cause accidents and must not extend beyond the stand limits.

All materials used must be removed without trace. Substances such as oil, grease, paint and similar must be removed from the floor immediately. Hall floors are not to be painted or glued. NürnbergMesse reserves the right to pass on the cost of repairing damage to the hall floor and removing soiling to the person responsible.

Carpets and other floor coverings in the exhibition areas have to be flame retardant to DIN 4102 B1 or EN 13501-1 Class C_{fl} as a minimum. A certificate verifying the building material class of the material used must be kept at the exhibition stand.

If high-pile carpet or floor coverings are made from synthetic grass, the fire and smoke behavior (according to EN 13501) in combination with the requirements for laying and installation must be taken into account since these floor coverings generally do not meet fire protection requirements. Further requirements regarding the necessary fire behavior are provided in 4.4.1.1. Anchors and fixing of stand structures in the hall floor are not allowed. The fixing of exhibits using floor anchors is only permitted in justified exceptional cases and with the written permission of NürnbergMesse. Exhibitors do not have a right to install and use floor anchors. Applications must be submitted on time (see 4.2) with scale plans showing the location, type of anchor, loading at the anchor and drilled hole diameter plus the number of anchors. The exhibitor must provide written evidence that the exhibit is also stable during operation. Tensile forces at the anchor are not permitted. The number of anchors must be limited to the quantity absolutely necessary. NürnbergMesse reserves the right to lay down the materials to be used for anchors. If unapproved materials are used or if floor anchors are installed without the written approval of NürnbergMesse, these will be removed at the exhibitor's expense (flat-rate repair cost of EUR 250 – net price per floor anchor) and risk by NürnbergMesse. Any heavy-duty anchors, screws or anchor bolts must be removed by the exhibitor or its representative during dismantling; care should be taken to ensure that anchor bolts are twisted out and may not be cut off flush. If this requirement is not

observed, the exhibitor shall be liable for consequential damage. NürnbergMesse is entitled to remove any heavy-duty anchors, screws or bolts left in place at the exhibitor's expense and risk. Stand structures that are not approved, or which do not comply with the Technical Guidelines or the current state of the art, must be modified or removed if required. If this is not done on time, NürnbergMesse is entitled to carry out the changes itself at the exhibitor's expense or to prohibit the use of the exhibits.

4.7.5 Suspending objects from hall ceilings

Use of truss systems

Use of lifting equipment

It is possible to hang objects from the facilities provided for this purpose in accordance with the relevant regulations DGUV Regulation 17 (formerly BGV C1); (see Instruction Sheet i4.9 "Suspension points, trusses and lifting equipment"). This also applies to pre-rig trusses and own ground support.

4.7.5.1 Provision of suspension points

The provision of suspension points and modification of suspension carried out exclusively by NürnbergMesse through its appointed ServicePartners. The suspension point will be provided for the exhibitor in the desired position in the space above the stand if structural conditions permit.

The number of possible suspension points in the halls depends on the stand size and the grid of the hall ceiling. The stipulated heights for construction and advertising must be observed. Suspension points incl. installed equipment are to be mounted with a residual clearance of at least 2.50 m below them.

NürnbergMesse checks the feasibility of the desired suspension points using the documents submitted and reserves the right to have the suspension loads and the rig used inspected by a structural engineer. This inspection is subject to a fee, which is charged to the **exhibitor or person ordering** the suspension points.

The maximum vertical structural load capacity of each suspension point is 25 kg (0.25 kN) for halls 1, 2, 3, 4, 5, 6, 7, 8, 9, 10 and 12 and the separation between suspension points in halls 1, 2, 3, 4, 5, 6, 7, 8, 9, 10 and 12 must not be less than 1.00 m.

The maximum vertical structural load capacity of the available suspension points in halls 3A, 4A, 7A and 11 is 250 kg (2.5 kN). Higher loads in the halls 3A, 4A, 7A and 11 are only possible on request and require written approval by NürnbergMesse. If the ordered suspension point is not below an existing suspension point or under the beams of the hall roof structure, the suspension point will be provided by using a pre-rig. The end of each suspension point (transfer point) is to be notified beforehand to the responsible ServicePartner using the order form.

The use of "bridles" at suspension points in the hall is not permitted on the NürnbergMesse site.

In the case of complex systems (statically indeterminate systems, generally more than single-span girders) a load plan must be submitted showing the total load and all concentrated and section loads. NürnbergMesse GmbH reserves the right to request the installation of load measurement systems for statically indeterminate systems. The load measurement systems are to be supplied, installed and operated exclusively by SAG GmbH. Load measurement systems are provided at extra cost, which will be charged to the exhibitor.

Please note that the use of load cells can reduce the maximum suspension height by up to 50 cm.

4.7.5.2 Attaching objects to suspension points

The objects to be suspended (lighting bars, spotlights, projectors, loudspeakers, etc.) may only be mounted by the exhibitor's own skilled staff, approved contractors **or the ServicePartner** in accordance with legal standards in force and current engineering practice. When selecting the skilled personnel on site or the supervising person (coordinator), the provisions of the current guidelines as per DGUV regulation 17 (formerly BGV C1/GUV C1), the DGUV Information Sheet 215-310 (formerly BGI 810) and in accordance with IGWV SQ Q2 (formerly VPLT SR3.0) must be observed. Evidence of the required qualifications must be carried.

When installing lighting trunking systems the associated spotlights and accessories must also be provided with an adequately dimensioned secondary fuse in accordance with the latest engineering practice (DGUV Information Sheet 215-313, formerly BGI 810-3). Further information on approved and non-approved attachment gear, load-bearing lines, load-bearing equipment, fasteners, rope terminations and lifting equipment can be obtained from **Instruction Sheet i4.9 "Suspension points, trusses and lifting equipment"**.

The regulations listed below must also be observed for safety reasons.

The following are prohibited:

- Suspension points used for securing stand components or exhibits (stand components or exhibits must stand securely on their own)
- Suspended constructions with a rigid or non-positive connection to the hall floor (structures with an additional connection to the roof supporting system as a result of suspension points)
- The use of bridle suspension points
- The use of bridle suspension points

Exceptions require the prior written approval of NürnbergMesse.

4.7.5.3 Use of truss systems

The use of trusses, rigs and truss systems is governed by the requirements and implementation instructions of DGUV Regulation 17 (formerly BGV C1/GUV C1), DGUV Information Sheet 215-313 (formerly BGI 810-3) and the industry standard SQ P1. This is independent of the type of use of the trusses, rigs or truss systems, which can be hung, moving or ground-supported. The use of trusses, rigs and truss systems outdoors is governed by the requirements for "temporary structures" (German FlBauR) (Code of practice for design and construction/DIN EN 13814 – Temporary structures and systems for event venues and safety in amusement parks).

For rigs that cannot support the load of a single-span girder (girder/truss on two supports or two suspension points), evidence of structural strength may be requested at the exhibitor's cost. The data sheets must be enclosed for the trusses used. If temporary structures are used, the building permit (Baubuch) must be carried.

4.7.5.4 Use of lifting equipment

The use of lifting equipment (electric chain hoists, manual chain hoists, etc.) is only possible in halls 3A, 4A, 7A and 11 and requires prior approval by NürnbergMesse.

The use of lifting equipment (electric chain hoists, manual chain hoists, etc.) in halls 1, 2, 3, 4, 5, 6, 7, 8, 9, 10 and 12 is strictly prohibited!

The use of lifting equipment is governed by the requirements and implementation instructions of DGUV Regulation 17 (formerly BGV C1/GUV C1), DGUV Information Sheet 215-313 (formerly BGI 810-3) and the industry standard SQ P2.

A suitable rope termination (e.g. ring or rope socket) must be provided. Wire rope fasteners (holders, sliders) are only designed for static loads and must not be used in conjunction with lifting gear. Secondary safety devices must be provided for all lifting equipment and slings (polyester round slings) in accordance with the latest engineering practice.

The use of lifting gear must be advised when ordering suspension points!

4.7.5.5 Electric chain hoists

Electric chain hoists may only be used in halls with heavy duty suspension devices (halls 3A, 4A, 7A and 11).

The use of this lifting gear is subject to the Requirements for Electric Chain Hoists in Event Technology (IGVV SQ P2).

The dead weight of the electric chain hoists and dynamic coefficients must be taken account of in the load plan so as not to overload the slinging points.

The contractor must subject the hoists to an annual inspection.

The test certification mark must be affixed to a visible location on the lifting equipment and the test documentation has to be available on site at all times. This inspection does not replace the inspection by an officially appointed expert every four years.

4.7.5.6 Manual chain hoists

Manual chain hoists may only be used in conjunction with heavy-duty suspension devices (halls 3A, 4A, 7A and 11).

Manual chain hoists may only be used in the case of statically determinate systems, i.e. a line load on two hoists or a distributed load on three hoists. The use of manual chain hoists for complex systems is not admissible.

The carrying and load hook of the hoist must be in a perpendicular straight line above the centre of gravity of the load. Winding round the load with the chain (carrier) or guiding the load chain over corners is not admissible.

Loads must always be moved with all attached manual chain hoists at the same time, i.e. there must be as many people lifting at the same time as there are manual chain hoists in use. It must be ensured that the lifting and lowering processes are uniform.

The dead weight of the manual chain hoists and dynamic coefficients must be taken account of in the load plan so as not to overload the slinging points.

4.7.6 Stand partition walls

The stand partition walls are fiber board or plastic-coated walls depending on the event. They are not suitable for mounting heavy objects and have no support function during assembly and dismantling. It may be necessary to erect additional supporting walls at extra cost, which may only be removed on the instructions of the organizer.

4.7.7 Advertising materials, presentations

The lettering on stands and exhibits, company logos and trademarks must not exceed the specified construction height and should create an attractive impression.

Presentations and slow-moving visual and acoustic advertising and musical reproductions are permitted, provided they do not annoy neighboring stands, do not cause congestion in the gangways and do not drown out the public address systems in the halls. The loudness at the edge of the stand must not exceed 70 dB(A). NürnbergMesse can intervene if these regulations are violated and may demand that the items causing the noise are shut down. In the case of show events the provisions of the German accident prevention regulation "Venues and production sites for stage presentations" (DGUV Regulation 17) must be observed.

Shows or product presentations with performance elements must be notified to NürnbergMesse, Exhibition Technology Departement (for contact details see 4.2).

The distribution of printed matter and the use of advertising material are permitted only in the exhibitor's own stand space. Advertising structures inside the stand must not protrude into the gangways or be mounted higher than the approved height. Advertising that contravenes legal regulations or offends against moral standards is not permitted. Advertising packages or advertising material of companies not registered at the event must not be displayed. Exhibits are not to be set up outside the stand limits. Possible advertising offers can be found in the Online ExhibitorShop (OES) under Marketing Services.

4.7.8 Accessibility

The stands must be designed to meet requirements for access by the disabled. Stands and their equipment should also be accessible to people with restricted mobility without needing the assistance of others.

4.8 Outdoor area

See 3.2

4.9 Two-storey stands

4.9.1 Application

Two-storey stands are only possible if authorized by NürnbergMesse. The application must be submitted immediately after receipt of stand approval and by the specified deadline (see 4.2). The necessary application form (**Form P1.1**) is obtainable from the respective exhibition team.

Two-storey stands are not possible in halls 10.1, 11.1 and 12.2.

4.9.2 Regulations on building over stand areas, safety clearances, height of rooms in stands

The maximum height of structures is shown in the Instruction Sheet: Hall details at a glance.

The clear height of inside rooms of two-storey stands must be at least 2.30 m on the ground floor and upper floor.

For fire safety reasons, a sprinkler system must be installed by the responsible ServicePartner BSS to protect the structure.

Stand structures bordering on neighboring stands are to be finished in a light and neutral single color above the height of 2.50 m.

4.9.3 Permissible loads/load assumptions

The vertical loads for the ceiling of a two-storey stand inside an exhibition hall must comply with DIN EN 1991-1-1/NA:2010-12 Table 6.1DE [Kat. C] as follows:

- Load required for restricted use by visitors or stand staff for meetings and customer support, i.e. furnished with tables and chairs arranged at random or divided into office cubicles $q_k = 3,0 \text{ kN/m}^2$ (Cat. C1).
- Load required for unrestricted use as freely accessible display and meeting area or as sales space with or without closely spaced seats: $q_k = 5.0 \text{ kN/m}^2$ (Kat. C).

The respective option must be clearly identified in the plans submitted for approval.

Staircases and stair landings must always be designed for a load (Cat. T2) of: $q_k = 5.0 \text{ kN/m}^2$.

To achieve sufficient longitudinal and lateral stability for two-storey exhibition stands or platforms, a horizontal load of $H = \sum q_k/20$ ($q_k =$ vertical load) is required at the height of the floor of the second storey.

For **balustrades and railings**, a horizontal load of $q_k = 1.0 \text{ kN/m}$ at handrail height (at least 1.10 m) must be applied according to DIN EN 1991-1-1/NA:2010-12 Table 6.12DE.

It must be verified that the permissible loads on the hall floor are not exceeded, e.g. by single supports (see 3.1 Hall data). If required, load-distributing floor panels have to be provided underneath the supports. Service ducts and covers must be covered with floor panels to prevent loads on them.

The proof of stand stability must take into account that floor anchors are not admissible.

4.9.4 Escape routes, stairs

The walking distance to the next hall necessary gangway from any accessible point on the top floor of a two-storey stand must not exceed 20 m.

The following minimum number and clear width of escape routes (exits, stairs and corridors) are to be provided:

- up to 100 m²: and less than 200 people 1 escape route (clear width 0.90 m)
- over 100 m²: and less than 200 people at least 2 escape routes (clear width 0.90 m)
- more than 100 m² and more than 200 people at least 2 escape routes (clear width min. 1.20 m)

If the floor space of the upper floor exceeds 100 m², at least two stairs are required. The permissible total escape route from any position to the nearest necessary gangway must not exceed 20 m. The stairs must be positioned opposite each other.

All stairs must conform to DIN 18065.

The necessary stairs and the stairs used for general visitor traffic must have closed steps.

The rise of the stairs must not exceed 0.19 m and the depth of the treads must not be less than 0.26 m.

Winding or spiral stairs are not permitted.

Hand rails must offer a firm grip and be continuous.

The side clearance between hand rails and adjacent parts must be at least 0.05 m.

Stairs of more than 1.20 m width must have handrails on both sides. Stairs more than 2.40 m wide must have central handrails.

4.9.5 Building materials

All stand construction and decorating materials must be fire-retardant to DIN 4102 minimum **B1 or** as per EN 13501-1 minimum **class B/C s1 d0**. They must not drip on burning or release toxic gases. In the case of two-storey stands the load-bearing structures, ceilings above ground floor and floor of top floor have to be made of flame resistant materials (to DIN 4102 or EN 13501-1) or flame retardant components as a minimum.

4.9.6 Upper floor

If balustrades are necessary on the upper floor, a lip of at least 5 cm must be provided on the floor at the base of the railings to prevent objects rolling over the edge.

Railings and balustrades are to conform to **Item 4.6** and **Item 4.9.3**.

If ceilings above the upper floor are closed design, the requirements for **stand monitoring** as per **Item 4.4.2** must be observed.

In addition to the fire extinguishers available on the ground floor, on the upper floor at least one fire extinguisher (EN3) must be provided ready for use in a prominent position for each stairway.

5. Industrial safety, technical safety regulations, technical rules, technical supplies

5.1 General regulations

Assembly and dismantling work may only be carried out in accordance with labour and industrial regulations. The exhibitor/stand builder is responsible for operating safety and for compliance with the Occupational Health & Safety and Accident Prevention Regulations on his stand.

5.1.1 Damage

The display areas must be restored to their original condition after dismantling. The exhibitor is responsible for any damage caused to the hall ceilings, walls, floors and installations. Stands not dismantled or exhibits not removed by the official deadline for dismantling may be removed and stored by the exhibition forwarding agent at the exhibitor's cost and risk. All damage caused to the halls, hall equipment or outdoor facilities by exhibitors or persons acting on their behalf must be reported to the organizer. Any damage caused to the exhibition grounds, buildings or equipment by exhibitors or persons acting on their behalf shall be remedied by NürnbergMesse at the exhibitor's expense after the end of the event.

5.2 Use of tools and equipment

The use of bolt-firing tools and nail guns is prohibited. The use of woodworking machines without sawdust extractors is prohibited. Sawdust extractors or shavings bins must be equipped with automatic fire extinguishing systems or dry standpipes. A suitable fire extinguisher to PG12 DIN EN 3 must also be available.

Rented elevating work platforms may only be operated by qualified persons above the age of 18 years. Proof of qualification to IPAF or DGUV Rules of Procedure 308-008 (formerly BGG 966) must be provided. Drivers must be in possession of driving licences at all times.

Cranes and forklift trucks may only be used by the forwarding agents appointed by NürnbergMesse.

For safety and liability reasons, working platforms etc. may only be requested via our ServicePartner SAG.

5.3 Electrical installation

5.3.1 Connections

Each stand to be supplied with electricity receives one or more connections with the necessary supply connection point. The installation of these connections is only to be carried out by the responsible ServicePartner of NürnbergMesse. The layout plan showing the desired position of the connections is to be enclosed with the orders on the order form. Electricity consumption will be charged at a fixed amount for connections up to 20 kW and based on meter readings for connections over 20 kW.

The power supply is available from the start of assembly until the end of dismantling. Other times of availability can be arranged with the responsible ServicePartner. The exhibitor is obliged to protect his supply connection point against damage and accidents.

5.3.2 Stand installation

Electrical installation work on the stand can be carried out to order by the responsible ServicePartner of NürnbergMesse. Installation work after the supply connection point on the stand can be carried out by the exhibitor's own electricians or by approved electrical contractors in accordance with VDE regulations, applicable European regulations and current engineering practice.

5.3.3 Installation and operating regulations

The entire electrical installation is to be carried out in accordance with the latest safety regulations of the Association of German Electrical Engineers (VDE) and Accident Prevention Regulations (DGUV Regulation 3, formerly BGV A3). The requirements of VDE 0100, VDE 0100-718, VDE 0128 and ICE Standard 60364-7-711 must be observed in particular.

The exhibitor assumes full liability for damage resulting that may occur due to faulty electrical installations on halls and building parts of NürnbergMesse and on the stands and exhibits of other exhibitors.

Protection with residual current devices (RCD) is mandatory for all power circuits.

A 30 mA RCD is specified as minimum protection for mains sockets and lighting circuits. Another suitable method of protection may be used for special machinery and equipment (frequency converters). The exhibitor is responsible for such measures.

The amount of high- or low-frequency interference with the mains supply must not exceed the limits stated in VDE 0160 and VDE 0838 (EN 50 006 and EN 61000-2-4).

Cables with a cross-section < 1.5 mm² are not permitted. Cables with solid conductors must be laid and connected permanently. Flexible cables must be provided with strain relief devices. The minimum specification for all cables used during assembly and dismantling is H07RNF or at least equivalent (VDE 0298). Cables such as H05... or similar may only be used in areas where they are subject to low mechanical loads (VDE 0298). Conductive components are to be incorporated in the precautions for protection against indirect contact (stand grounding and/or equipotential bonding).

Secondary circuits (all cables from the provided electrical connection) must be protected from short-circuit and overload using suitable circuit breakers.

Low-voltage systems may only be operated with safety transformers to DIN EN 61558 (VDE 0570) or 61046/61047 or equivalent. The transformers must be suitable for installation on combustible surfaces and their primary and secondary circuits equipped with protection against overheating, short-circuit and overload.

Bare (uninsulated) electrical conductors are prohibited in low-voltage lighting systems. All terminal connections have to end in a closed box. Flexible cables (and flat cables) must not be laid under floor coverings without protection against mechanical loads.

The electrical installation on the stand may not be taken into operation for the event until it has been accepted and inspected and approved by an authorized person. An acceptance report must be available for inspection on the stand.

5.3.4 Safety measures

As a special precaution, all heat-generating electric appliances (hot plates, spotlights, coffee percolators, etc.) are to be mounted on non-combustible, heat-resistant, asbestos-free bases.

Depending on the heat generated, sufficient separation is to be maintained from combustible materials.

Light fittings may only be mounted on non-combustible decorations etc. Spotlights, floodlights, spotlights on luminaire tracks and their supply fittings such as power rails, switch boxes or similar are to be secured individually with wire safety ropes to current standards. The stand lighting must be switched off at night.

Unauthorized modifications to hall lighting such as removing individual fluorescent bulbs is prohibited.

5.3.5 Emergency lighting

Additional separate emergency lighting in accordance with VDE 0100-718 is required for stands whose special construction renders the existing general emergency lighting system ineffective.

This is to be designed to ensure safe access to the general escape routes.

5.4 Water and waste water installation

Each stand to be supplied with water and waste water drainage receives one or more connections to current standards.

When providing the water connections the inlet is installed with a ½ inch hose and the outlet with a 50 mm pipe. Connections are from the service ducts in the hall floor (position as per hall layout). Within the stand the piping is laid on the hall floor so that its routing can be agreed beforehand with the responsible ServicePartner and the installation height of pipes and cables taken into account as necessary.

All installations inside the stands have to comply with the current regulations and engineering practice (e.g. drinking water regulations and DIN 1988), so as to prevent any lasting impairment of drinking water quality due to the installation and operation of a connection.

These connections may only be installed by the responsible ServicePartner of NürnbergMesse. The layout plan showing the desired position of the connections is to be enclosed with the orders on the order form.

Continuous flow coolers (carbonators) may not be connected directly to the drinking water supply.

It is forbidden to take water from hydrants or other fire extinguishing equipment.

For safety reasons, the water supply is shut off on the last day of the exhibition – usually one hour after closing time!

For more information, guidelines and conditions see Online ExhibitorShop (OES) under Water supply and drainage.

5.5 Compressed air and gas installation

5.5.1 Compressed air

Each stand to be supplied with compressed air receives one or more connections of the required size. The supply connection point is always fitted with a ball valve or quick coupler.

The installation of these connections is only to be carried out by the responsible ServicePartner of NürnbergMesse.

The layout plan showing the desired connection points is to be enclosed with the orders on the order form.

The amount of compressed air used is included in the connection charge.

Compressed air is available during the official assembly and dismantling period. During the event, compressed air is available from 8:00 until closing time. For safety reasons, the compressed air supply is shut off at all other times.

Compressed air can be provided outside the stated times by arrangement and at extra cost.

5.5.1.1 Stand installations

The installation of compressed air lines from the main connection and connections to exhibits inside stands can be ordered from the responsible ServicePartner of NürnbergMesse or carried out by suitably qualified outside contractors.

5.5.1.2 Installation and operating regulations

The hoses and fittings used must be rated for a minimum operating pressure of 10 bar and protected against mechanical loads. The hoses must be laid and fixed to allow the smallest possible freedom of movement in the event of an accident – especially at the joints.

5.5.1.3 Compressed air cylinders

The large capacity of the supply network means that compressed air chambers/cylinders are not normally required for the operation of exhibits. If compressed air containers are to be used in exceptional cases, they are subject to approval and must be rated for a minimum operating pressure of 10 bar and equipped with fittings tested by the Technical Inspection Authority (TÜV).

The inspection log for the specified initial inspection and regular 5- or 10-year inspections must be available on the stand.

Compressed air containers must pass an acceptance inspection by an authorized person before being taken into operation and the inspection certificate must be available on the stand.

5.5.1.4 Compressors

NürnbergMesse maintains a dense network of compressed air outlets with good coverage. Compressors for operating exhibits may only be used on the stands by arrangement with the exhibition team.

Compressors to be operated as exhibits in the halls must conform to the German or equivalent foreign safety regulations and be insulated to ensure that the noise level measured at the edge of the stand does not exceed 50 dB(A). The manufacturer's EC declaration of conformity is to be available at the stand.

The exhibitor is responsible for proper disposal of condensates and solids containing oil and waste oil. Evidence of this is to be available at the stand.

5.5.2 Gas

If technical gases are used, the stock held on the stand is to be limited to the smallest amount possible and the container renewed several times a day if necessary.

Storing gas bottles at the stand to meet daily requirements is only possible during the trade fair period and must be registered using **Form P2**. During the assembly and disassembly periods and at night, the gases (and/or compressed gas cylinders) are generally to be stored outside the halls.

Gas bottles must be equipped with approved safety valves and these must be closed at the end of operation. Only a single bottle of combustible technical gases with a maximum filling weight of 5 kg per stand is permitted in the halls. Non-combustible technical gases are limited to max. 14 kg. Only the gas bottle currently connected and in use is allowed on the stand.

If larger amounts of technical gases are required for operating an exhibit, NürnbergMesse will consult the exhibitor, the responsible supervisory authority and the ServicePartners to find a storage facility outside the hall and cover the bottles with a non-combustible ventilated shield to protect against heat radiation. The line to the equipment in operation and the supply line are to use permanent pipes or flexible metal-reinforced hoses. The equipment in operation is to be placed firmly on a large, non-combustible underlay with sufficient separation from heat sources (see **Item 5.7.1.1**).

An acceptance certificate is to be prepared by the ServicePartner of NürnbergMesse and submitted to the organizer. The specified **instructions for operating the system** must be displayed in a prominent position.

For storage and transport, please refer to **Items 5.6.3 Pressure vessels and 5.7 Use of compressed gases, liquid gases and combustible liquids**.

5.6 Machines, pressure vessels, exhaust gas systems

5.6.1 Machine noise

The operation of machinery and equipment causing noise is to be limited as far as possible in the interest of all exhibitors and visitors. The noise at the edge of the stand must not exceed 70 dB(A).

5.6.2 Product safety

All exhibited products must fulfill the requirements of the Product Safety Act (ProdSG, ProdHG and ProdSV) and the respective harmonized EU regulations. Products not conforming to these requirements must bear a sign in a prominent position stating that they do not conform to the requirements of the above-mentioned act and cannot be purchased until they comply with the statutory requirements (as per §3 section 5 ProdSG).

The relevant manufacturer's declaration of conformity must be available on the stand for products bearing the CE marking.

For demonstrations, the necessary protective precautions must be taken by stand staff. Your attention is also drawn to the Product Liability Act (ProdHaftG).

5.6.2.1 Safety devices

Machines and apparatus may only be taken into operation with all safety devices in place. The normal safety devices may be replaced with a safety cover of organic glass or a similar transparent material.

If equipment is not being operated, the safety devices can be removed to show visitors the design and finish of the covered parts. In this case, the safety devices must remain in a clearly visible position next to the machine.

5.6.2.2 Inspection procedures

The technical equipment on display will be inspected for accident prevention and safety by the responsible supervisory authority for each exhibition, if necessary with the responsible trade association committees, and checked for compliance with the safety requirements.

The EC declaration of conformity must be available for inspection on the stand to enable the authority to check the CE marking. In case of doubt, the exhibitor should contact the responsible authority at an early stage before the start of the exhibition.

5.6.2.3 Ban on operation

NürnbergMesse is entitled to ban the operation of machinery, apparatus and equipment at any time, if such operation is deemed to constitute a hazard to persons and property or adversely affect other exhibitors or the orderly running of the exhibition.

5.6.3 Pressure vessels

5.6.3.1 Acceptance certificates

Pressure vessels may only be operated on the stand if the inspections stipulated in the Occupational Health and Safety Regulations (German BetrSichV) have been carried out. The associated inspection certificates are to be available at the installed location of the pressure vessel and presented to the responsible supervisory authority on request. Information about the relevant regulations is obtainable from the responsible ServicePartner of NürnbergMesse.

5.6.3.2 Testing

A certificate for the structural and water pressure test is not sufficient. This requirement also applies to rented vessels or those manufactured abroad. If notified by the specified deadline (see 4.2), pressure vessels requiring testing can be given an acceptance inspection by the responsible ServicePartner of NürnbergMesse up to the day before the event opens, provided the structural/water pressure test certificate is presented and a fitter is available for this task on the stand. The responsible ServicePartner of NürnbergMesse will answer any inquiries.

5.6.3.3 Rented equipment

If the assessment of pressure vessels not manufactured in Germany is not possible in the relatively short assembly period of the exhibition, tested rented vessels are to be used.

5.6.3.4 Supervision

The necessary acceptance certificate must be available for the trade inspectorate during the event. Information for specific exhibitions is available from the responsible supervisory authority.

5.6.4 Exhaust gases and vapors

Combustible and/or oily vapors and gases emitted by exhibits and equipment that constitute a health hazard or nuisance to the general public must not be discharged into the halls. They must be discharged outside through suitable pipes in accordance with the German Federal Immission Control Act.

Vapors or odors given off by cooking appliances must not be discharged into the hall but have to be removed using an exhaust air system or treated using suitable activated carbon or aerosol separators.

- 5.6.5 Exhaust gas systems**
Exhaust gas systems are to be approved in writing by NürnbergMesse.
- 5.7 Use of compressed gases, liquid gases and combustible liquids**
- 5.7.1 Compressed and liquid gas systems**
The storage and use of compressed and liquid gas in the exhibition halls or outdoor area is prohibited unless approved in writing by NürnbergMesse.
- 5.7.1.1 Application to use compressed gas cylinders**
If liquid gas or other combustible gases in pressure cylinders are to be used for presenting exhibits, written approval must be obtained from NürnbergMesse by the specified deadline using Form P2. In accordance with the relevant accident prevention regulations, compressed gas cylinders must be protected against impact, falling over, unauthorized use and heating up.
- 5.7.1.2 Use of liquid gas**
See 5.5.2
- 5.7.1.3 Installation and maintenance**
Liquid gas systems are to be installed and maintained in accordance with the "Technical Rules for Liquid Gas" TRF 2012 (published by: DVGW Deutscher Verein des Gas- und Wasserfaches e.V. and DVG Deutscher Verband Flüssiggase e.V.) and the "Code of Practice for the Use of Liquid Gas" ZH 1/455 (published by: Hauptverband der gewerblichen Berufsgenossenschaften).
- 5.7.2 Combustible liquids**
- 5.7.2.1 Storage and use**
The storage and use of combustible liquids (see Health and Safety at Work Regulations (German: BetrSichV), TRBS 2152 and 2153, TRGS 509 and 510 in the halls and outdoor area is prohibited unless written approval has been granted. Approval of the storage and use of combustible liquids can only be granted for the operation or demonstration of exhibits.
Application on the appropriate form is to be submitted to NürnbergMesse together with the safety data sheet. Please use Form P2 to register such liquids.
For advertising and decorative purposes empty drums (dummies) are to be used.
- 5.7.2.2 Required storage**
The quantity of combustible liquids kept on the stand for operation and demonstration purposes must not exceed the amount required for one day. The required quantity is to be stated in the application.
- 5.7.2.3 Storage containers**
The daily requirement is to be stored in an orderly manner in closed unbreakable containers. It must not be accessible to unauthorized persons. Storage containers are to be kept in non-combustible drip trays.
- 5.7.2.4 Place of storage**
A strict ban on smoking is to be enforced at the storage location. Suitable signs must be provided. Suitable portable fire extinguishers must be available.
- 5.7.2.5 Conditions for operation**
Any equipment requiring combustible liquid for operation or demonstration purposes must be provided with non-combustible drip trays under its filling caps and at other points where spillage could occur.
Any leakages of combustible liquids are to be removed from the drip trays immediately due to the possible fire or explosion hazard and disposed of safely.
- 5.7.2.6 Filling of liquids**
Filling the liquids is especially hazardous and must be done with great care and caution.
- 5.7.2.7 Empty containers**
Empty containers used for combustible liquids must not be kept or stored on the stand or in the hall.
- 5.7.3 Fuel pastes and other fuels**
Heating and cooking appliances using wood, charcoal, gas, combustible liquids or fuel pastes are not allowed in the halls.
- 5.8 Asbestos and other hazardous substances**
The use of materials or products containing asbestos, or of hazardous building materials and other dangerous substances is prohibited. This ruling is based on the Protection against Hazardous Substances Act (Chemicals Act), Federal Law Gazette (German BGBl) 1, Part 1, page 1703, in conjunction with the Prohibited Chemicals Act (Chem.Verbots V) and the Hazardous Substances Regulations (GefStoff V).
- 5.9 Performance areas**
Performance areas are areas used for artistic and other performances; areas of less than 20 m² used for performances do not constitute performance areas.
For performance areas of more than 50 m² or 200 m², "event equipment directors" must be appointed in accordance with § 39 of the Bavarian Venue Regulations (BayVStättV) in conjunction with § 40.
- 5.10. Radiation protection**
Information about radiation protection can be obtained from the trade associations, local accident insurers and the responsible trade inspectorate.
- 5.10.1 Radioactive substances**
The handling of radioactive substances is subject to approval and arrangement with NürnbergMesse. According to the Radiation Protection Regulations (StrlSchV), approval is to be applied for from the State Environmental Protection Office and submitted to NürnbergMesse by the specified deadline (see 4.2). If approval already exists, evidence must be provided that the intended handling of radioactive substances in the exhibition grounds is legally permitted.
- 5.10.2 X-ray systems and stray radiation sources**
The operation of X-ray systems and stray radiation sources is subject to approval and arrangement with NürnbergMesse. The Regulations on Protection against Damage by X-Rays (German RÖV, BGB, I) must be observed. The operation of X-ray systems and stray radiation sources is subject to approval or notifiable in accordance with § 3, 4, 5 and 8 of RÖV. The authority responsible for the exhibition grounds is the Nuremberg Trade Inspectorate and applications must be submitted in writing on time (see 4.2) (see Instruction Sheet i4.11).
- 5.10.3 Laser systems**
The operation of laser systems is subject to approval and arrangement with the Exhibition Technology Department of NürnbergMesse (see Instruction Sheet i4.10 "Laser systems"). The operation of laser systems is to be notified to the responsible authority in accordance with § 6 of the Accident Prevention Regulation "Laser Radiation" (German DGUV Regulation 11, formerly BGV B2). Notification is to be accompanied by a written order for the appointment of a laser safety officer for operation of the laser system. In addition, the requirements of the Occupational Safety Regulation on Artificial Optical Radiation 2006/25 EC/OSTrV, TROS Laser, DIN EN 60825-1, DIN EN 12254 and in the case of show lasers DIN 56912 must be met. Class 3R, 3B or 4 devices/systems must generally be inspected on site by an officially appointed expert and declared safe before use. A copy of the inspection report is to be submitted to NürnbergMesse.
When adjusting and operating the laser equipment technical and organizational measures must be taken to ensure that no-one is exposed to laser radiation in excess of the maximum admissible limits. A laser safety officer is to be nominated in writing by the exhibitor. When demonstrating laser devices it must be ensured that no uncontrolled reflected radiation can occur and that the laser and/or projection area is not accessible to anyone. The authority responsible for industrial safety is the Nuremberg Trade Inspectorate (see Instruction Sheet i4.10).

- 5.11 High-frequency equipment, radio installations, electromagnetic compatibility and harmonics**
 The operation of high-frequency equipment and radio systems is to be approved by the Federal Network Agency. Operation is to be notified to and can only be approved by NürnbergMesse to achieve an even distribution of frequencies and prevent mutual interference as far as possible.
 The operation of high-frequency equipment and radio systems is only permitted if they comply with the provisions of the Telecommunications Act and the Electromagnetic Compatibility Act (German EMVG).
 If exhibits are displayed or stand decorations used that involve electric, magnetic or electromagnetic fields, the provisions of the 26th Regulation on the Implementation of the Federal Immission Control Act are to be observed.
 Sources of strong magnetic fields must be notified to NürnbergMesse specifying the location on the respective stand.
 The electrical installations of the exhibits and stands are to be designed to prevent unacceptably large interference with the network through harmonics in the exhibition center supply network (see Item 5.3.3).
 Bundesnetzagentur (Federal Network Agency)
 Außenstelle Nürnberg
 Breslauer Straße 396, 90471 Nürnberg
 Tel +49 (0) 9 11. 9 80-40
 Fax +49 (0) 9 11. 9 80-41 80
 poststelle@bnetza.de
 www.bnetza.de
- 5.12 Cranes, forklift trucks, empty containers**
 The operation of exhibitors' own cranes and forklift trucks is not permitted. Only equipment supplied by the appointed ServicePartner may be used in the exhibition grounds.
 The responsible ServicePartners exercise sole forwarding rights in the exhibition grounds, i.e. the delivery of exhibits, stand structures etc. to the stand, incl. provision of any auxiliary equipment and customs handling for temporary or permanent importation.
 Orders placed with the forwarding agents are subject to the current edition of the General German Forwarding Conditions (German ADSp) and the Forwarding Tariff for Trade Fairs and Exhibitions at NürnbergMesse.
 Any liability of NürnbergMesse for all risks arising out of the work of the forwarding agents is excluded.
 The storage of any kind of empty containers on the stands, in the gangways or in free areas not approved as storage areas is prohibited. Empty containers are to be removed to the empties storage location by the forwarding agents approved for the exhibition grounds without delay.
 Obstructing the fire brigade access roads, wall hydrants, fire doors and escape routes with empty containers or waste is strictly prohibited (see 2.). NürnbergMesse reserves the right to have illegally deposited empty containers removed by the approved forwarding agents at the cost of the exhibitor.
- 5.12.1 Exhibiting heavy and bulky exhibits and machinery**
 To ensure smooth transport of heavy and bulky items during the assembly and dismantling phase, timely consultation with the responsible forwarders (ServicePartner) is necessary.
 If your item being delivered measures more than 3.00 m x 2.50 m x 4.00 m or exceeds a total weight of 5.0 t, you must notify the responsible ServicePartner of the forwarding company at least four weeks in advance.
 If necessary the delivery must be made on the first day of assembly or in special cases during assembly that has been brought forward. This must be agreed in advance with NürnbergMesse.
 When erecting the exhibits please observe the maximum admissible floor loads in the halls. To avoid excessive foundation pressure concentrated loads have to be distributed via load-distributing floor panels, so that the maximum admissible area loading is not exceeded. Service ducts and covers must be covered with suitable floor panels to prevent loads on them.
 If floor anchors are needed for the secure presentation of your exhibits, please note the requirements of 4.7.4.
- 5.13 Musical reproduction**
 According to the legal provisions (Copyright Act), permission is required from the Society for Musical Performance and Mechanical Reproduction Rights (German GEMA) for any form of musical reproduction. Unregistered musical reproduction can lead to claims for damages from GEMA under § 97 of the Copyright Act. Applications and inquiries are to be sent to:
 GEMA-Bezirksdirektion Stuttgart
 Key Account Management
 Herdweg 63
 70174 Stuttgart
 Tel +49 (0) 7 11. 22 52-7 94
 Fax +49 (0) 7 11. 22 52-8 00
 messe@gema.de
 www.gema.de
 Acoustic and visual demonstrations also require approval by NürnbergMesse. Approval is granted on condition that the loudness at the edge of the stand during operation of the system does not adversely affect exhibition operation and other stands and does not constitute a health hazard. In the event of repeated failure to comply with these rules, the power supply to the exhibitor's stand can be interrupted without regard to the associated effects of the power failure. The exhibitor shall not be entitled to claim for direct or indirect damage caused by the interruption of the power supply.
 It is the responsibility of the exhibitor to provide evidence of compliance with the regulations. Media equipment is to be placed far enough away from the edges of the stand so that interested visitors must enter the stand and do not obstruct visitor traffic in the gangways.
- 5.14 Beverage dispensing systems**
 Beverage dispensing systems on the stand are to be installed and operated in accordance with the Operating Safety Regulations and DIN 6650-6.
 Compliance with technical and food hygiene requirements must be demonstrated and may be checked by the Public Order Office. Food hygiene regulation No. 852/2004 dated 29 April 2004 of the European Parliament and Council will apply.
 Notice of the use of pressurized gas containers must be submitted to NürnbergMesse using Form P2 (see 5.5.2).
- 5.15 Food safety monitoring**
 The serving of samples for immediate consumption and the sale of food and drinks on the stand must conform to the statutory regulations and the current standards, especially food hygiene regulations.
 For further information please contact
 Stadt Nürnberg – Ordnungsamt Lebensmittelüberwachung
 Innerer Laufer Platz 3
 90403 Nürnberg
 Tel +49 (0) 9 11. 2 31-25 24
 Fax +49 (0) 9 11. 2 31-30 70
 lebensmittelueberwachung@stadt.nuernberg.de
 www.ordnungsamt.nuernberg.de
 Over-the-counter sales of food and drinks (including bar sales) at the event itself are not permitted.
- 5.15.1 Requirements to be met by stand/kitchen facilities**
 The kitchen facilities absolutely must comply with the following requirements:
 - Hand-washing facility with running hot and cold water with liquid soap and disposable hand towels must be provided.
 - Crockery and glasses must be washed with running hot and cold water and/or a dishwasher is to be provided.
 - Smear-resistant floor coverings, washable wall coverings and storage areas are to be provided in food preparation and storage areas.

- The floors in the work area must be non-slip, flat and impermeable to liquids.
- Effective spittle/sneeze guards must be installed in the food service area.
- Functioning cooling equipment for perishable food
- Install effective exhaust air systems or extractor hoods with active charcoal filters if vapors or odours can be expected when food is being prepared or kept warm.
- Provide suitable number of portable fire extinguishers (to EN3, foam extinguishers or extinguishers for cooking oils and fats). At least one cooking oil/fat fire extinguisher and fire blanket for each cooking area (fire classification F to DIN EN2).

5.15.2 **Cooking appliances and food preparation processes**

Cooking appliances

Cooking equipment (e.g. deep fat fryers, fryers, large frying pans etc.) may only be electric and must be operated under supervision in the halls following notification to NürnbergMesse.

At the end of each day of the event the appliances must be switched off at the mains. The mains switch must be clearly marked EMERGENCY OFF switch.

Cooking appliances and equipment must not be installed in traffic routes at the stand or directly next to hall gangways. A minimum distance of 1.5 m is to be observed. Any exceptions to this must be submitted for approval to the Exhibition Technology Department (for contact details see 4.2).

Deep-fat fryers or similar equipment must not be used in the top storey of multi-storey stands. For fire safety reasons when using deep fat fryers a non-flammable canopy must be provided so that in the event of a hot grease fire there is no effect on the hall sprinkler system.

The maximum filling level is 40 l (filling level of adjacent appliances to be added up). If the maximum level is going to be exceeded this must be discussed with NürnbergMesse beforehand.

5.15.3 **Grilling/barbecuing**

Grilling/barbecuing in the halls and outdoor area is allowed subject to the prior written authorization of NürnbergMesse. If permission is given, only electric grills/barbecues may be used inside the halls and the vapors/smoke must be discharged outside using suitable exhaust systems.

5.15.4 **Drinking water**

Drinking water for food preparation may only be taken from drinking water taps. The use of drinking water from the toilets or the sinks dedicated for use by painting contractors is prohibited.

6. **Environmental protection**

NürnbergMesse is committed to pro-active protection of the environment. As contractual partner of NürnbergMesse, the exhibitor is obliged to ensure that all binding regulations and standards concerning environmental protection are also observed by his contractors.

6.1 **Waste management**

All the following rules are based on the requirements of the Recycling Management Act (German KrWG), the associated implementation provisions and regulations, the "state laws" and "local government by-laws".

The city of Nuremberg has issued a by-law on waste management which governs waste prevention and waste sorting and is binding on exhibitors and organizers.

The exhibitor is responsible for proper and environmentally compatible disposal of waste produced during assembly and dismantling and during the event.

The technical handling of disposal for recycling and removal is solely incumbent on NürnbergMesse or its appointed ServicePartner.

6.1.1 **Waste disposal**

According to the principles of recycling management, all unnecessary waste is to be avoided during assembly and dismantling and during the event. Exhibitors and their contractual partners are obliged to effectively contribute to this in every phase of the event. This aim must be pursued by all concerned in the planning and coordination phases. This especially applies to packaging material, advertising material, carpets, disposable stand equipment, empty containers, pallets and disposable crockery. As a general principle, reusable and environment-friendly materials are to be used where possible for stand construction and operation.

Every exhibitor is responsible for the proper and environment-compatible disposal of his own unavoidable waste.

The following waste disposal options are available to the exhibitor: 1. The exhibitor can make his own arrangements to dispose of the waste outside the exhibition grounds at his own cost. 2. Proper disposal of the waste at extra cost by the official ServicePartner of NürnbergMesse by placing an order using the Online ExhibitorShop (OES).

The disposal of waste in waste containers or in other facilities of the Nuremberg exhibition grounds is expressly prohibited.

Exhibitors are obliged to hand over their stand spaces in a clean condition at the end of the event. This particularly applies to materials left on the hall floor (e.g. remains of adhesive tape etc.). See **Item 4.7.3**. If a completed and signed order form is not received by the return deadline, NürnbergMesse assumes that the exhibitor will make his own arrangements for waste disposal. If waste is not or not completely disposed of in this case, NürnbergMesse will appoint the official ServicePartner to perform this work at the cost of the respective exhibitor. The amount of any waste remaining in the halls will be estimated in m³ and the exhibitor charged for its disposal at the higher official price. The exhibitor shall also ensure that all waste is properly disposed of by the subcontractors, stand construction companies and other partners he has appointed for his stand. Please co-operate – think of the environment!

6.1.2 **Hazardous waste**

The exhibitor is obliged to notify NürnbergMesse of waste whose type, property or quantity is especially hazardous to health, air or water, explosive or combustible (e.g. batteries, coatings, solvents, lubricants, paints, etc.) and to arrange their proper disposal by the responsible ServicePartner.

6.1.3 **External waste**

Materials and waste not produced in connection with assembly and dismantling or the duration of the event are not to be brought into the exhibition grounds.

6.2 **Water, waste water, soil protection**

6.2.1 **Oil and grease separators**

The amounts discharged into the waste water network must not exceed the level of pollutants deemed normal for households. If waste water containing oil or grease exceeding these levels is to be discharged, oil and grease separators must be used. If mobile catering units are used, fats and oils must be collected and disposed of separately.

6.2.2 **Cleaning, cleaning agents**

The exhibitor is obliged to hand over his stand space in a clean condition at the end of the event. This particularly applies to materials left on the hall floor. All cleaning work is to be done using biologically degradable products. Cleaning agents containing solvents that are damaging to health are only to be used in exceptional cases as laid down in the regulations.

6.3 **Environmental damage**

Environmental pollution/contamination (e.g. through petrol, oil, solvents, paint) is to be reported to NürnbergMesse without delay.

Instruction sheet "Technical data for halls" 2017

Stand utilities

Hall equipment

i4.1

Hall/floor	Hall area in m ²	Hall doors width x height in m	Lifts W x H x D payload	Max. floor load in kN/m ² (1 kN = 100 kg)	Clear height to lower edge of strip lighting in m	Suspensions	Stand utilities			Hall equipment					
							Electricity	Water	Compressed air	Telephone	Sprinklers	Smoke alarms	Heating	Ventilation	Refrige- ration
1	10,800	4 4.05 x 4.90	4 x 4.05 x 4.90	50	5.80 / 9.80	■	■	■	■	■	■	■	■	■	■
2	4,680	2 4.05 x 4.90	2 x 4.05 x 4.90	50	5.80	■	■	■	■	■	■	■	■	■	■
3	12,730	3 4.10 x 3.80	3 x 4.10 x 3.80	50	5.80	■	■	■	■	■	■	■	■	■	■
3A	8,400	3 5.65 x 5.10	3 x 5.65 x 5.10	50	10.0 - 15.00	■	■	■	■	■	■	■	■	■	■
4	11,690	3 Door 2 + 3 Door 1 4.50 x 4.80 4.00 x 4.80	Door 2 + 3 Door 1 4.50 x 4.80 4.00 x 4.80	50	5.80	■	■	■	■	■	■	■	■	■	■
4A	7,100	5 4.50 x 4.85	5 x 4.50 x 4.85	50	15.00/5.80	■	■	■	■	■	■	■	■	■	■
5	7,840	3 4.05 x 4.90	3 x 4.05 x 4.90	50	5.80	■	■	■	■	■	■	■	■	■	■
6	7,840	3 4.05 x 4.90	3 x 4.05 x 4.90	50	5.80	■	■	■	■	■	■	■	■	■	■
7	16,410	6 Door 1 + 6 Door 2 - 5 4.50 x 4.80 4.00 x 4.90	Door 1 + 6 Door 2 - 5 4.50 x 4.80 4.00 x 4.90	50	5.80	■	■	■	■	■	■	■	■	■	■
7A	8,850	5 4.65 x 4.80	5 x 4.65 x 4.80	50	15.00/4.90	■	■	■	■	■	■	■	■	■	■
8	4,680	2 4.05 x 4.90	2 x 4.05 x 4.90	50	5.80	■	■	■	■	■	■	■	■	■	■
9	10,800	4 4.05 x 4.90	4 x 4.05 x 4.90	50	5.80	■	■	■	■	■	■	■	■	■	■
10.0	6,720	2 5.05 x 3.95	2 x 5.05 x 3.95	20	5.30 (UK Prerigg 4.95)	■	■	■	■	■	■	■	■	■	■
10.1	6,870		2.45 x 2.45 x 4.5 m 3.500 kg	10	3.50 (UK Prerigg 3.50)	■	■	■	■	■	■	■	■	■	■
11.0	5,340	2 5.20 x 4.15	2 x 5.20 x 4.15	50	10.50	■	■	■	■	■	■	■	■	■	■
11.1	4,780		West: 2.40 x 2.45 x 3.7 m 3.200 kg East: 2.25 x 2.45 x 3.7 m 3.200 kg	5	3.60	■	□	□	□	□	□	□	□	□	□
12.0	13,730	4 5.00 x 4.40	4 x 5.00 x 4.40	50	5.80	■	■	■	■	■	■	■	■	■	■
12.2 Permanent stand area	13,330		2.4 x 2.45 x 4.95 m 6.375 kg	10		□	□	□	□	□	□	□	□	□	□

□ possible / provided with limitations ■ possible / provided

Instruction sheet

“Instructions on installing sprinkler-compatible ceiling fabrics” 2017

General information on stand coverings

Ceiling surfaces must be in materials that as a minimum meet the requirements of building material classes DIN 4102 (B1) or DIN EN 13501 B-C and do not drip on burning (see Instruction Sheet Building Material Classes, i4.4).

Kitchens and storage areas must always be open to the top.

From a continuous covered area of 30 m² a sprinkler system must be provided.

The sprinkler system may only be dispensed with:

- if the ceiling is a grid design, whereby not more than 30 % (CEA 4001S) of the ceiling area may be closed referred to the individual square meters. Allowance has to be made for additional lighting fixtures or other installations in the ceiling. or
- if the fabrics used have been approved by VdS Schadenverhütung GmbH Cologne for use in risk areas with sprinklers. The installation of open mesh fabrics must be in accordance with VdS specifications (see VdS approval certificate).

The use of mesh fabrics and materials with "smoke-out" protection is prohibited. You will find an overview of approved fabrics here:

<https://vds.de/verzeichnisse/pwlaprodukte/?context=PWLA&bid=324511000&aid=&ctrl=2&lang=de>

N.B.:

Regardless of their dimensions and design, stand coverings larger than 25 m² must always be registered using Form P2 from the Exhibitor Service Manual and require the written approval of NürnbergMesse Exhibition Technology Departement. veranstaltungstechnik@nuernbergmesse.de

Basic requirements for mesh fabrics:

- Several ceiling sections of up to 30 m² are possible within a stand provided there is a minimum distance of 3.00 m between the individual ceiling sections.
 - So as not to exceed the maximum area of 30 m² when adding up several ceiling sections, **a distance of minimum 1.50 m to the stand boundaries must be maintained.**
- Any reduction of this 1.50 m distance (e.g. to the gangways) must be authorized by the Exhibition Technology Departement.
- The current test certificate documenting sprinkler compatibility and the building material class of the material used must be available at the stand for inspection from the assembly period and beyond.

Instruction sheet

“Special exemption from ban on use of trucks on Sundays” 2017

All trucks exceeding 7.5 t and trucks with trailers require special approval as per § 46 Para. 1 No. 7 in conjunction with § 30 Para. 3 of the German highway code (StVO) for planned journeys between 00.00 and 22.00 h on Sundays and public holidays (§ 30 Para. 4 StVO).

For journeys between the officially signed truck parking areas of NürnbergMesse and the exhibition site, permits issued by the road traffic authorities can be obtained direct at the signed truck parking areas from Engelhardt & Co.

These permits apply only to the routes marked in color on Annex 1 between NürnbergMesse and the signed parking areas. The permit is also valid for the use of vehicles in the “Grosse Strasse” and throughout the exhibition site.

All fees for these permits are paid by NürnbergMesse, so no costs are incurred by the companies.

The holidays for which permits are to be obtained are based on § 30 Para. 4 StVO.

Irrespective of the permit for restricted travel between the truck parking areas of NürnbergMesse and the exhibition site, whose fees are paid by NürnbergMesse, unrestricted special approval can be obtained by the forwarding agent or driver direct from the Nuremberg road traffic authorities at Strassenverkehrsbehörde, Servicebetrieb Öffentlicher Raum SÖR/3-S, Bauhof 2, 90402 Nürnberg, Tel +49(0)911. 231-4591, Fax +49(0)911. 231-3655.

Application forms and information can also be obtained on the Internet (German only):

www.soer.nuernberg.de -> Formulare und Anwendungen (Forms and Applications).

These are usually the following public holidays:

- | | | |
|------------------------|----------------------|--------------------------|
| - New Year's Day | - Labour Day | - German Unification Day |
| - Twelfth Day | - Ascension Day | - All Saints' Day |
| - Good Friday | - Whit Sunday/Monday | - Christmas Day |
| - Easter Sunday/Monday | - Corpus Christi | - Boxing Day |

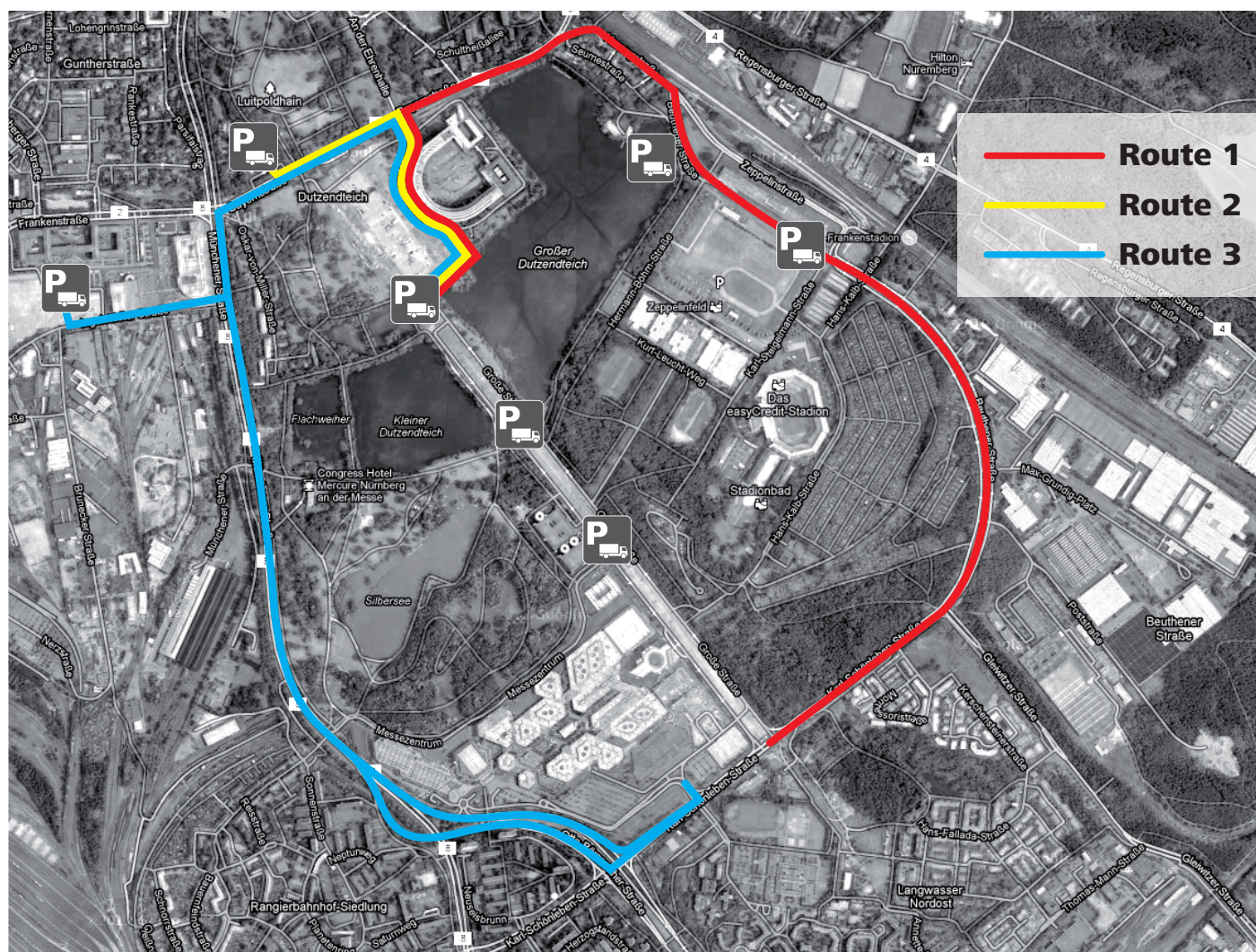

Instruction Sheet “Fire prevention – European classification of building products” 2017

European classification of building products

Additional requirements				Additional requirements					
Building authority designation	DIN 4102	DIN EN 13501	Smoke production	Flaming particles/droplets	Building authority designation	DIN 4102	DIN EN 13501	Smoke production	Flaming particles/droplets
Non-combustible	A1	A1	no/hardly	no drips/droplets	Difficult to ignite	B1	C – s1, d1	no/hardly	limited drips/droplets
Non-combustible	A2	A2 – s1, d0	no/hardly	no drips/droplets	Difficult to ignite	B1	C – s1, d2	no/hardly	many drips/droplets
Difficult to ignite	B1	A2 – s1, d1	no/hardly	limited drips/droplets	Difficult to ignite	B1	C – s2, d0	limited	no drips/droplets
Difficult to ignite	B1	A2 – s1, d2	no/hardly	many drips/droplets	Difficult to ignite	B1	C – s2, d1	limited	limited drips/droplets
Difficult to ignite	B1	A2 – s2, d0	limited	no drips/droplets	Difficult to ignite	B1	C – s2, d2	limited	many drips/droplets
Difficult to ignite	B1	A2 – s2, d1	limited	limited drips/droplets	Difficult to ignite	B1	C – s3, d0	unlimited	no drips/droplets
Difficult to ignite	B1	A2 – s2, d2	limited	many drips/droplets	Difficult to ignite	B1	C – s3, d1	unlimited	limited drips/droplets
Difficult to ignite	B1	A2 – s3, d0	unlimited	no drips/droplets	Difficult to ignite	B1	C – s3, d2	unlimited	many drips/droplets
Difficult to ignite	B1	A2 – s3, d1	unlimited	limited drips/droplets	Normal combustibility	B2	D – s1, d0	no/hardly	no drips/droplets
Difficult to ignite	B1	A2 – s3, d2	unlimited	many drips/droplets	Normal combustibility	B2	D – s1, d1	no/hardly	limited drips/droplets
Difficult to ignite	B1	B – s1, d0	no/hardly	no drips/droplets	Normal combustibility	B2	D – s1, d2	no/hardly	many drips/droplets
Difficult to ignite	B1	B – s1, d1	no/hardly	limited drips/droplets	Normal combustibility	B2	D – s2, d0	limited	no drips/droplets
Difficult to ignite	B1	B – s1, d2	no/hardly	many drips/droplets	Normal combustibility	B2	D – s2, d1	limited	limited drips/droplets
Difficult to ignite	B1	B – s2, d0	limited	no drips/droplets	Normal combustibility	B2	D – s2, d2	limited	many drips/droplets
Difficult to ignite	B1	B – s2, d1	limited	limited drips/droplets	Normal combustibility	B2	D – s3, d0	unlimited	no drips/droplets
Difficult to ignite	B1	B – s2, d2	limited	many drips/droplets	Normal combustibility	B2	D – s3, d1	unlimited	limited drips/droplets
Difficult to ignite	B1	B – s3, d0	unlimited	no drips/droplets	Normal combustibility	B2	D – s3, d2	unlimited	many drips/droplets
Difficult to ignite	B1	B – s3, d1	unlimited	limited drips/droplets	Normal combustibility	B2	E		
Difficult to ignite	B1	B – s3, d2	unlimited	many drips/droplets	Normal combustibility	B2	E – d2		many drips/droplets
Difficult to ignite	B1	C – s1, d0	no/hardly	no drips/droplets	Easily ignited	B3	F		

The following conditions apply at the NürnbergMesse site (acc. to DIN EN 13501):

unrestricted approval

approved up to 2.50 m wall construction/not approved over people (d1)

not approved (D, E, F, s3 or d2)

Key to building product classes: to DIN 4102

A1 = non-combustible (without combustible components)

A2 = non-combustible (with combustible components to a minor extent)

B1 = difficult to ignite

B2 = normal combustibility

B3 = easily ignited

Key to building product classes: to DIN EN 13501

A1 = non-combustible (without combustible components)

A2 = non-combustible (with combustible components to a minor extent)

B,C = difficult to ignite

D,E = normal combustibility

F = easily ignite

s1 = no/hardly any smoke production

s2 = limited smoke production

s3 = unlimited smoke production

d0 = no drips/droplets

d1 = limited drips/droplets

d2 = many drips/droplets

General Information

Pyrotechnic presentations require approval and must be coordinated with NürnbergMesse (Exhibition Technology Department).

If pyrotechnic effects are used on the NürnbergMesse site, the exhibitor/organiser must obtain approval from the competent regulatory agency, the Industrial Trade Inspectorate, and the Nuremberg Fire Department by max. 4 weeks before the actual event.

A copy of the approved application must be submitted to NürnbergMesse by no later than 2 weeks before the start of the event. Approval of the articles may be taken from the relevant packing unit. In addition, any instructions for use on the packaging must be printed on in German. Pyrotechnic objects without approval or pyrotechnic objects in Class II, III or IV are not allowed.

For further information, please contact:

NürnbergMesse GmbH

Abteilung Veranstaltungstechnik
Messezentrum, 90471 Nürnberg
veranstaltungstechnik@nuernbergmesse.de
www.nuernbergmesse.de

For pyrotechnic presentations, the following applications and notifications should be noted.

- **Application for a license to test stage pyrotechnics in accordance with Art. 23 (4) of 1st Explosives Act (German SprengV)**
(Responsible authority: Nuremberg fire brigade)
- **Notification of the use of stage pyrotechnics in accordance with Art. 23 (4), (5) of 1st Explosives Act**
(Responsible authority: Trade Inspectorate)
- **Application for a license to show stage pyrotechnics in the presence of visitors and cast**
(Responsible authority: Public Affairs Office)

Application for exemption from the notification deadline (subject to a fee)

Return to:

**Stadt Nürnberg
Feuerwehr**

Feuerwache 5
Karl-Schönleben-Straße 80, 90471 Nürnberg

Tel +49 (0) 9 11.2 31-65 00
Fax +49 (0) 9 11.2 31-65 05

**Regierung von Mittelfranken
Gewerbeaufsichtsamt Nürnberg**

Dezernat 2
Roonstraße 20, 90429 Nürnberg
gewerbeaufsichtsamt@reg-mfr.bayern.de

Tel +49 (0) 9 11.9 28-0
Fax +49 (0) 9 11.9 28-29 99

**Stadt Nürnberg
Ordnungsamt**

Waffenrecht
Innerer Laufer Platz 3, 90403 Nürnberg
waffenrecht@stadt.nuernberg.de

Tel +49 (0) 9 11.2 31-23 50
Fax +49 (0) 9 11.2 31-40 06

1. License holder in accordance with Art. 7 of Explosives Act

Surname	First name	Company
Name and address of issuing authority		Date of issue
		License no.

Does the license holder possess the necessary expert knowledge?

Enclose copy of proof of expert knowledge if resident outside Central Franconia.

Yes No

2. Expert knowledge of person responsible for display

Information on certificate of competence or license

Name and address of issuing authority (<input type="checkbox"/> as at 1. if applicable)	Date of issue	No. of license/certificate of competence
--	---------------	--

Surname	First name	Company
---------	------------	---------

Street, number	Postcode	Town
----------------	----------	------

Telephone	Fax	E-mail (if available)
-----------	-----	-----------------------

3. Event director, exhibition director (NM), event equipment director (NM)

Event director in accordance with Art. 38 of Bav. Venue Regulations (Bayr. VStättV)

Surname	First name	Company
---------	------------	---------

Street, number	Postcode	Town
----------------	----------	------

Telephone	Fax	E-mail (if available)
-----------	-----	-----------------------

For guest events with external organizers:

Has the **exhibition director** of NürnbergMesse GmbH been informed about the use of pyrotechnic articles?

Yes No

Has the **event equipment director** of NürnbergMesse GmbH in accordance with Art. 39 of the Bavarian Venue Regulations been informed about the use of pyrotechnic articles?

Yes No

4. Information about the use of pyrotechnic effects

Venue (hall/building, room, area, level) Date of use Duration of use (from – to)

Event

Client

Notification must be submitted at least **two weeks before the planned use** of the pyrotechnic effects.

5. Type and scope of planned stage pyrotechnic effects

Class (BAM no.)	Trade name	Rise	Safety clearance (in surrounding area and above)	Duration of effects	Number
-----------------	------------	------	---	---------------------	--------

6. Date of test:

Date	Time	Venue (hall/building, room, area, level)
------	------	--

7. Planned security measures:

During preparation

During display

General

8. Miscellaneous/remarks (e.g. special hazards or safety improvement measures)

9. Enclosures:

– Copy: License/certificate of competence

10. License charges to be invoiced to

Surname	First name	Company
---------	------------	---------

Street, number	Postcode	Town
----------------	----------	------

Telephone	Fax	E-mail (if available)
-----------	-----	-----------------------

I hereby confirm the correctness and completeness of the information provided above.

Place and date

Company stamp and authorized signature

Instruction Sheet

“Use of fog machines”¹ 2017

Fog machines may only be used after prior consultation with NürnbergMesse (Event Technology) in due time before the event. The request must be submitted in writing using form P2. NürnbergMesse must be notified of the type and model of fog machine used and the data sheet, the fog machine operating instructions and the safety data sheet for the fog fluid are to be submitted. Proof of regular inspections of the machine must also be provided if applicable. NürnbergMesse will charge the organizer for the cost of substitute measures if firefighting appliances must be deactivated before operating a fog machine. The organizer and/or person responsible will be charged for the cost of calling out the fire brigade if the fire alarm system is set off without prior consultation with NürnbergMesse.

Only fog machines conforming to the basic requirements of the current Equipment and Product Safety Act (German GPSG) may be provided and used.

If vaporizing fog machines are provided and used, the declaration of conformity of these machines must confirm compliance with DIN VDE 0700-245.

The type of use and the specific operating conditions must be taken into account when selecting fog machines. The user of the fog machines must be in possession of the relevant operating instructions.

General hazards associated with the use of fog machines

The conditions for the use of fog effects are based on the performance requirements and an assessment of the risk.

The fog is to be limited to the necessary amount and agreed with all concerned. Suitable measures are to be implemented to reduce the fog as much as possible in areas in which it is not required for performance effects.

The following hazards are to be included in the risk assessment of all types of fog production:

- **Visibility obstructions**

Obstacles, places with a risk of falling or injury like stairs, lowered areas, exits, sharp edges, etc. are to be marked especially clearly if fog is used, likewise escape routes and emergency exits.

If thick fog is used and obstacles, hazardous areas or their marking are not visible, special care is necessary to avoid these hazards.

Fog must not cause warning and safety equipment and particularly escape route signs to become unrecognizable.

- **Risk of slipping**

Fog directed onto a cold and smooth surface from a short distance away can cause condensation. Even thin layers of moisture can cause a risk of slipping and constitute a hazard, particularly for dancers, artistes and all other actors within the range of the fog machines.

Measures must be taken to prevent condensation and the accompanying risk of slipping occurring within a radius of one to two meters.

Condensation on the performance area and spilt fluids must be removed as quickly as possible.

- **Reaction of respiratory passages**

As a high concentration of fog can cause a reaction in susceptible persons (e.g. dryness of the respiratory passages due to the hygroscopic property of fog), the use of fog must be notified in good time before the event. Higher concentrations may especially occur in the performance area.

- **Creation of hazardous substances through inappropriate use**

Fog fluids and additives (e.g. fragrances and processing aids) are only to be used in fog machines if they are declared as suitable for the machine by the manufacturer. The instructions for use apply.

The arbitrary mixing of fog fluids with fragrances and other additives is not allowed and users are not to mix different fog fluids or prepare their own fog fluids.

- **Risk of fire and explosion**

Fog fluids that are inflammable, easily flammable or highly flammable within the meaning of Art. 4 of the current Hazardous Substances Act (German GefStoffV) shall not be used indoors.

The fog produced must not create any flame in the outlet area and not be combustible. No ignition sources are to be located near the fog outlet. A safety clearance of at least one meter is to be maintained. Fog fluids may only be stored in the manufacturer's original containers.

If fog is used in rooms monitored by automatic fire detectors, the fire alarm system must be deactivated within the range of the fog machines. In this case, equivalent substitute measures are to be implemented, for example, a fire watchman.

Because of the open building structure in parts of the site (e.g. entrance areas, congress centres, etc.) or the layout of automatic fire alarms in inaccessible areas, the use of fog machines may also be prohibited in general.

Fog machines not in use are to be disconnected from the mains to prevent the risk of fire through overheating after a fault.

- **Risk of malfunctioning of fog machines**

Only properly maintained fog machines are to be used and these must pass a visual and functional inspection without faults. Unpleasant smells, machines that do not work correctly or the discharge of unvaporized fluid indicate defective operation. Such machines are to be serviced or repaired.

Technical maintenance is to be performed at regular intervals by the manufacturer or in accordance with the manufacturer's instructions.

Types of fog production:

Fog through cold	typical:	for ground fog, e.g. using dry ice, liquid nitrogen
Fog through heating	possible:	clouds, room fog, mist, also ground fog, e.g. vaporizer
Fog through mech. methods	typical:	mist, e.g. atomizer method (crackers)

Fog through cold: e.g. “DRY ICE”

Ground fog is usually produced by vaporizing dry ice, which is frozen carbon dioxide. The fog is distributed passively or with the help of a low-power fan.

Dry ice fog machines are equipped with a water tank and electric heating elements in the tank heat up the water to temperatures near the boiling point depending on the system. Measures to protect against scalding may be necessary depending on the temperature of the water bath.

Carbon dioxide gas is heavier than air. It can accumulate in low areas and force out the air. This constitutes a risk to life in performances at floor level – for example, persons lying on a floor covered with dry ice fog.

A risk of poisoning or suffocation exists if the concentration of carbon dioxide is not sufficiently diluted. To protect against these hazards, measures must be taken to prevent the accumulation of carbon dioxide in hollows and low areas. This may require extracting the (invisible, odorless) carbon dioxide from hollows and discharging it into the outside air.

Dry ice is very cold (minus 80 °C) and can cause frostbite on direct contact. Dry ice and any residues are to be stored to prevent access by unauthorized persons.

Personal protective equipment is required for handling dry ice: protective gloves, gloves insulated against the cold and, if necessary, safety goggles.

The hazards and protective measures necessary for using nitrogen for fog production differ only slightly from those for handling dry ice.

Instruction Sheet

“Use of fog machines¹” 2017

(continued)

Fog through heating: e.g. “VAPORIZER”

Most fog for stage effects is created with vaporizer fog machines.

In these machines the fog fluid is sucked out of a tank or container, heated and pressed through a jet. The fluid is a mixture of alcohols and water. The alcohols used are hygroscopic. The bonded water forms the fog after passing through the jet and the cooling and expansion processes. The properties of the fog produced can be influenced by the choice of fog fluids and the machine settings.

Ground fog can also be produced with the aid of attachments. Here the fog from a vaporizer fog machine is cooled until it is distinctly heavier than air and sinks correspondingly quickly.

To provide information about the ingredients of the fog fluids or fragrance additives, the manufacturer’s information and a safety data sheet must be requested and be available for inspection at the event. Only fog fluids with vaporization temperatures that match the temperature of the vaporizer are to be purchased.

Risks can occur if inferior quality fluids are used with component properties that are irritating or damaging to health.

The addition of fragrance additives to the fluid and exceeding the stated optimum fog temperature of the fluid must be carefully avoided to exclude possible hazards through unknown reactions.

There is a risk of burning on the hot surface of the fog outlet. It may also be necessary to wait until the machine cools down before removing protective covers.

Fog through mechanical methods: e.g. “atomizer method” (crackers)

Oil crackers atomize oil by mechanical means without heating it. The oil mist produced is very stable and does not mix with the surrounding air.

Water/glycol crackers atomize the fog fluids in the same mechanical way as oil crackers. The fog fluid consists of water and polyvalent alcohols.

The condensation deposited by the fog on equipment – such as performance areas, decorations, trusses and machines – is a problem, as it creates a risk of slipping.

Oil fog and water/glycol fog are preferably used only in areas that the cast do not need to enter.

The condensation must be removed as quickly as possible.

Attention must also be paid to the special features of operating compressors and accessories. The system is to be depressurized before changing fittings, hose connections or additional elements.

For further information, please contact:

NürnbergMesse GmbH

Abteilung Veranstaltungstechnik

Messezentrum

90471 Nürnberg

veranstaltungstechnik@nuernbergmesse.de

www.nuernbergmesse.de

¹ Instruction sheet based on: OHS information “Special Stage Effects and Operations” (DGUV Information 215-315, formerly BGI 810-5)

Suitability of fire extinguishers:



- Powder
- Foam
- Water



Powder extinguisher with ABC powder Water and foam extinguisher

Fires involving solid materials, mainly of an organic nature, which normally form flames and embers on burning



- Powder
- Foam
- CO²



Powder extinguisher with BC and ABC powder Foam extinguisher CO² extinguisher

Fires involving liquids or melting materials



- Powder



Powder extinguisher with BC and ABC powder

Fires involving gases (e.g. propane, butane etc.)



- Powder



Powder extinguisher with D powder

Fires involving metals (e.g. magnesium, aluminum swarf)



- Foam



Fires involving fat and oil, extinguisher marked orange

DIN EN 3 provides for the following sizes: 1 kg, 2 kg, 3 kg, 4 kg, 6 kg, 9 kg, 12 kg

- The fire classes of fire extinguishers **have nothing** in common with the classification of building products to DIN 4102 and DIN EN 13501.
- The fire classes define **the suitability** of fire extinguishers for fires involving various materials, liquids or vapours that have caught fire.

Explanation of official designation of fire extinguishers:

DIN EN 3	Current European standard
6	Weight/charge in kg
PG	Code letter: In this case ABC powder

Table:

Designation	Extinguishing agent	Code letter
Water extinguisher	Water and aqueous solutions	W
Foam extinguisher	Foam	S
Powder extinguisher	ABC powder	PG
	BC powder	P
	D powder	PM
Carbon dioxide extinguisher	Carbon dioxide (CO ²)	K

Example of specified labeling to DIN EN 3:

FEUERLÖSCHER
12 Kg ABC-Pulver
43 A 183 B C

1 Ventil voll aufdrehen

2 Löschpistole betätigen

VORSICHT BEI ELEKTRISCHEN ANLAGEN. NUR BIS 1000 V; MINDESTABSTAND 1m

Nach jeder Betätigung neu füllen!
Löcher längstens alle 2 Jahre auf Einsatzbereitschaft überprüfen. Nur solche Lösch-Treibmittel und Ersatzteile verwenden, die mit dem anerkannten Muster übereinstimmen.

Löschmittel: 12 kg ABC Nr. der Anerkennung: DIN EN 3
 Treibmittel: 280 g CO₂ Typ: G 12 R

Funktionsbereich: -20 °C bis +60 °C

HERSTELLER:

Information sheet

“Glass and acrylic glass” 2017

This information sheet is jointly
agreed upon by

Deutsche Messe AG Hannover
KölnMesse GmbH
Leipziger Messe GmbH
Messe Berlin GmbH
Messe Düsseldorf GmbH
Messe Frankfurt Venue GmbH
Messe München GmbH
NürnbergMesse GmbH

Berlin, den 1.12.2012

CONTENTS

1.	SCOPE OF APPLICABILITY
2.	DEFINITIONS AND CLARIFICATIONS
2.1	Types of supports
2.2	Types of glass and acrylic glass
2.3	Design calculation standards
2.4	Material properties of glass products
3.	STAND DESIGN, CONSTRUCTION AND LOADS
3.1	Vertical glazing not intended to prevent falling
3.1.1	Vertical glazing of a height $h \leq 4$ meters above hall floor level
3.1.2	Vertical glazing of height $h > 4$ meters above hall floor level
3.2	Vertical glazing intended to prevent falls
3.2.1	Category A – vertical glass wall
3.2.2	Category B – clamped glass balustrade with continuous handrail
3.2.3	Category C – Railing and balustrade infills and glass walls with load-distributing cross-bar fitted in front of it
3.3	Horizontal glazing
3.3.1	Overhead glazing
3.3.2	Glazing designed to support human loads
4.	APPROVAL PROCEDURES
4.1	Basics
4.2	Installation approval for a specific case
5.	NOTES ON DESIGN AND DESIGN CALCULATIONS
6.	EXAMPLES OF STRUCTURES (BARRIERS) DESIGNED TO PREVENT FALLS
6.1	Category B
6.2	Category C1
6.2.1	Railing infills secured vertically on 2 sides
6.2.2	Railing infills secured horizontally on 2 edges
6.2.3	Railing infills secured on 4 sides
6.2.4	Glazing secured at individual points by means of drilled anchorage points (design specifications in accordance with TRAV and/or DIN 18008-4)
6.2.5	Point mounting with lateral clamps and anti-slip grips
6.2.6	Point mounting with clamps at top and bottom
6.3	Balustrade with horizontal bars (protection against falling is provided solely by sufficiently strong handrails and knee-height bars)
7.	CONSTRUCTION ENGINEERING REGULATIONS, GENERALLY ACCEPTED RULES OF ENGINEERING AND REFERENCES
8.	ABBREVIATIONS
9.	KEYWORD INDEX
10.	TABLES CONTAINING INFORMATION FOR STAND BUILDERS

1. Scope of applicability

This information sheet discusses the regulations concerning the use of glass and acrylic glass in stand construction and design inside trade fair halls. It does not apply to stand construction and design outside trade fair halls.

Designing, dimension calculations and assembly of glass components for use inside trade fair halls require that the design, planning and assembly personnel involved is adequately qualified for glass construction projects. Glass structures which have received general construction approval (including European Technical Approval ETA) may be used in all cases in trade fair halls in accordance with the wording of the approval. This information sheet does not impose restrictions on the use of such structures.

2. Definitions and explanations

2.1 Types of supports

- Glazing secured by linear supports: secured by linear supports on at least two opposite edges over the full length of each edge of the glass plate.
- Glazing secured at individual points: glazing anchored through drilled holes or by a clamping system.

2.2 Types of glass and acrylic glass

Types of glass granted statutory construction approval in Building Regulation List A:

- **Float glass** (polished plate glass – PPG) as specified in DIN EN 572-2: Also called flat or plate glass. It is characterised by relatively low ultimate flexural strength, and when destroyed, it fragments into large sharp-edged shards. Its use as single sheet glazing in trade fair construction is prohibited. If used in LSG, it is permitted in trade-fair construction.
- **Tempered safety glass (TSG)** as specified in DIN 12150-1: TSG is a fully thermally pre-stressed type of glass. It has internal residual stress characteristics: core tensile stress and surface compression

stress. It has high ultimate flexural strength and when broken, it shatters into crumb-like fragments. Where TSG is referred to in this information sheet, TSG made of float glass is always meant.

- Laminated safety glass (LSG):

LSG consists of at least two sheets of PPG, TSG or HSG glass. The individual thicknesses of these are not permitted to differ from each other by a factor of more than 1.5. The sheets of glass are laminated together by intermediate film layers (PVB or SGP films). If a sheet is broken, then the film prevents the fragments from being scattered, thus providing residual load-bearing capacities and reducing the risk of injury from cuts.

- Heat-strengthened glass (HSG) as specified in DIN EN 1863-1 or with other general approvals by building authorities (German: allgemeine bauaufsichtliche Zulassung – abZ):

HSG is a type of glass that is only partially thermally pre-stressed. Its ultimate flexural strength is lower than that of TSG (tempered safety glass). When broken, HSG fragments into shards which are larger than those of broken TSG. Therefore LSG sheets made of HSG have higher residual load-bearing capacities than LSG sheets made of TSG. HSG laminated with PVB film is included in Building Regulation List A. A general construction approval by building authorities (German allgemeine bauaufsichtliche Zulassung – abZ) for the SGP film is required for HSG laminated with SGP.

Types of glass for which no statutory construction approval has been granted:

- Acrylic glass:

Acrylic glass is a transparent thermoplastic product marketed under the brand names *Plexiglas®* and *Perspex®*, for example. At present no recognised technical regulations are available for the use of acrylic glass.

- Polycarbonate products: e.g. Makrolon

Acrylic glass and polycarbonate may only be used for non-load-bearing, decorative infill components.

2.3 Design calculation standards

The static strength proof calculations for glass components can be carried out in accordance with the following design calculation concepts and structural design standards:

Design concept	A: comprehensive safety concept	B: load factor concept
Proof concept	$\sigma < \text{allow. } \sigma$	$\sigma_k \cdot \gamma_f < f_k \cdot k_c \cdot k_{mod} / \gamma_M$
Determination of action effects and stresses	at SLS (GZG) ^{*)}	at ULS (GZT) ^{*)}
Deformation checks	at SLS (GZG)	at SLS (GZG)
Designation of forces / stresses in the serviceability limit state SLS (forces due to characteristic loads, without γ_f)	no designation, SLS (GZG)	SLS (GZG) after the number or index k after formula symbol e. g. supporting force = 12 kN (SLS) or $F_k = 12 \text{ kN}$
Designation of forces / stresses in the ultimate limit state ULS (forces due to characteristic loads, multiplied by γ_f)		LS (GZT) after the number or index d after formula symbol e. g. supporting force = 16 kN (ULS) or $F_d = 16 \text{ kN}$
Designation of the allowable material stress	allow. σ or allowable σ	
Designation of the limit stress		f_k
Dimension calculation rules, dimension calculation standards	TRLV [5] TRAV [6] TRPV [17]	DIN 18008-1 [12] DIN 18008-2 [13] DIN 18008-3 [14] DIN 18008-4 [15] DIN 18008-5 [16]
Standards applying to loads and actions	this information sheet and DIN EN 1991-1-1 DIN EN 1991-1-1/NA: (2010-12)	this information sheet and DIN EN 1991-1-1 DIN EN 1991-1-1/NA: (2010-12)
Normal load factors γ_f for permanent loads (e.g. dead loads)		1.35
Normal load factors for variable loads and actions (e.g. dynamic pressure, imposed loads, cross-bar pressures)		1.5
Duration of loads typically encountered at trade fairs for k_{mod} , taken from DIN 18008-1, Table 6.		Own weight: permanent ($k_{mod} = 0.25$) Working loads: medium ($k_{mod} = 0.4$) Horizontal substitute load: short ($k_{mod} = 0.7$) Cross-bar pressure: short ($k_{mod} = 0.7$)

^{*)} German designations and abbreviations Grenzzustand der Gebrauchstauglichkeit - GZG and Grenzzustand der Tragfähigkeit - GZT [as listed in chapter 8] for the respective limit states.

For static load calculations, either concept A, comprehensive safety, or concept B, load factors, shall be used as a basis. The two concepts must not be mixed (used together). After the design dimension calculation concept A or B has been chosen, all design requirement specifications (e.g. flexing limits, glass clamping depth etc.) given in the set of standards chosen for the design concept are to be applied. The verbal description and the symbols and abbreviations used in equations must make it absolutely clear which concept is being applied. Supporting forces transmitted by glass components must always be stated for the SLS (GZG) and the ULS (GZT) so that the loads of the connected force-transmitting components of concrete, steel or wood can be calculated using the load-factor concept without transmission errors.

Information sheet

“Glass and acrylic glass” 2017 (continued)

2.4 Material properties of glass products

Glass products have a bulk density of 25 kN/m³, a thermal expansion coefficient of 8.4·10⁻⁶/K and their Young's modulus is 70,000 N/mm². For structural design calculations, the bending stresses listed in *Table 1* are allowed (concept A) or the design calculation values of the resistance R_d listed in *Table 2* must be observed (concept B).

Table 1: Allowable bending stresses for various glass sorts, in N/mm² (for static proof calculations according to the allowable stress concept)

	Toughened/ fully- tempered glass (TSG)	Enamelled glass (printed glass)		Heat-streng- thened glass HSG	LSG made with float glass (PPG)	Float glass (polished plate glass PPG)	Wire glass (only for existing components)
		TSG	HSG				
Overhead glazing	50	30	18	29	15	12	8
Vertical glazing	50	30	18	29	22.5	18	10

Table 2: Normal material properties for design calculation concept B, application of load factors

Property	Polished plate glass (not printed, not sand-blasted)	HSG (not printed, not sand-blasted)	TSG (not printed, not sand-blasted)
Normal limit stress f_k as spec. in DIN EN 572-1, DIN EN 1863- 1 or abZ, DIN EN ISO 12150-1	45 N/mm ²	70 N/mm ²	120 N/mm ²
Design coefficient k_c , normal	1.8	1	1
k_{LSG} for laminated safety glass	1.1	1.1	1.1
k_{edge} (k_{Kante}) for calculating the effect of glass edges	0.8	1	1
Material factor γ_M	1.8	1.5	1.5
Modification factor for calculating the effect of load durations	permanent: 0.25 medium duration: 0.4 short: 0.7		
Rated value of the resistance to stress failure R_d	$R_d = k_{mod} \cdot k_c \cdot k_{VSG} \cdot k_{Kante} \cdot f_k / \gamma_M$	$R_d = k_c \cdot k_{VSG} \cdot k_{Kante} \cdot f_k / \gamma_M$	$R_d = k_c \cdot k_{VSG} \cdot k_{Kante} \cdot f_k / \gamma_M$

The intermediate films in LSG shall be made of PVB or SGP (*SentryGlas® plus*). Films made of PVB must have tear strength of at least 20 N/mm². SGP films shall have general approval by building authorities (including European Technical Approval ETA) and shall be processed in accordance with this approval.

3. Stand design, construction and loads

3.1 Vertical glazing not intended to prevent falling

3.1.1 Vertical glazing of a height $h \leq 4$ metres above hall floor level

Neither static proof of structural characteristics in accordance with the regulations specified in chapter 2.3 is required, nor is it necessary to submit documentation of testing. In this case the exhibitor alone is responsible for ensuring that the construction/design is technically safe for general use and that it meets current and accepted technical standards. Table A provides an overview of the types of structural designs that are possible.

- Either TSG or LSG must be used.
- The glass sheets may be secured by linear supports or at individual points.
- Glass walls tilting at an angle of more than 10° from the vertical are considered to be overhead glazing for which the provisions of chapter 3.3 shall apply.
- Additional measures, e.g. provision of static proof calculations similar to those described in chapter 3.1.2, may be required to ensure protection of neighbouring walkways, or to be able to bear the loads of persons leaning against or bumping into the glass.

3.1.2 Vertical glazing of height $h > 4$ metres above hall floor level

Vertical glazing not intended to prevent falling and whose uppermost edges are higher than 4 metres above hall floor level does not require Installation approval for a specific case (c.f. 4.2) provided that the type of glass used, structural design details and the type of supports securing the glass comply with the regulations specified in chapter 2.3. In addition, the following provisions shall be observed.

- Verified structural calculations or structural calculations suitable for verification and the corresponding construction plans must be submitted.
- In addition to the load of its own weight, the material must be capable of resisting horizontal forces, i.e. a pressure corresponding to at least $h_1 = 0.125$ kN/m² for visible surfaces of up to 4 m above hall floor level and at least $h_2 = 0.063$ kN/m² for visible surfaces at more than 4 m above hall floor level.
- Wherever there is a high risk of impact, e.g. where there is a descending ramp leading towards the glazing, additional measures are required.
- Proof of structural characteristics is not required if the area of each individual sheets is less than 1.6 m² and TSG with a thickness of at least 4 mm is used, and the sheet(s) is (are) held on four sides by linear supports.

Glazing secured at individual points may be used without further proof documentation if:

- general construction approval (abZ) has already been granted for the combination of point-mounting method and glass type and thickness, or
- The design specifications, and the dimensions and thickness of the glass as stated in TRAV, TRPV, DIN 18008-3, DIN 18008-4 or Table B are adhered to.

TRAV, DIN 18008-3 / -4 and Table B are referred to above because the fall-prevention glazing barriers described in these references are of course also suitable for glass panels not explicitly intended to prevent falls.

Installation approval for a specific case is required for all other designs. If the use TSG glazing is planned, a heat soak test certificate must be submitted.

Table A provides an overview of possible designs and the necessary proofs.

3.2 Vertical glazing intended to prevent falls

In all three of the following categories, A, B and C, static load proof calculations for the glass and the supporting structures and proof of the load-bearing capacity under impact-like conditions are required. The static structural design calculations for the glass and the supporting structure shall be based on an assumed cross-bar pressure load and as an additional load case, a horizontal assumed surface load of $h_1 = 0.125$ kN/m² for all visible surfaces at up to 4 m above the hall floor level and of $h_2 = 0.063$ kN/m² for surfaces located at more than 4 m above hall floor level.

The load-bearing capacity of the structure under impact action can be verified as follows:

- a pendulum impact test in accordance with DIN EN 12600 if design calculation concept A is used, or in accordance with DIN 18008-4 if design calculation concept B is used, or
- the relevant design specifications, glass dimensions and thicknesses as stated in Table B of this information sheet are adhered to, or
- by providing proof calculations in accordance with the rules described in chapter 2.3.

“Glass and acrylic glass” 2017 (continued)

Table B contains an overview of possible designs and the proofs required. All structural design details (including flexing/sag and glass insertion/clamping depths) shall be modelled in accordance with the rules described in chapter 2.3.

Pendulum impact tests must be carried out by one of the test centres/institutes named in chapter 4 well in advance of the fair and outside the trade fair halls.

3.2.1 **Category A – vertical glass wall**

Definition: Linearly-supported vertical glazing that does not contain any load-bearing bars at capping height and is not protected by a rail or cross-bar located in front of it, making it suitable for the direct action of rail or cross-bar loads, e.g. glazing of full room height.

If protection is required to prevent persons falling from a height of more than 1 metre, then it will be necessary to refer to the Technical Regulations for the Use of Accident-Prevention (barrier) Glazing [Technische Regeln für die Verwendung von absturzsichernden Verglasungen (TRAV)] or DIN 18008-4.

- Only LSG shall be used.
- Verified proof of structural characteristics or static structural calculations suitable for verification, as well as a pendulum impact test (test in accordance with DIN EN 12 600 or DIN 18008-4) are required.
- The pendulum impact test is not required for glass with linear support on all sides, provided that the appropriate dimensions and glass thickness conform to Table B (or TRAV 6.3. and Table 2), DIN 18008-3 and DIN 18008-4, or proof calculations are carried out in accordance with DIN 18008-4.
- The glazing supports must provide adequate protection to the edges of the glass sheets.

3.2.2 **Category B – clamped glass balustrade with continuous handrail**

Definition: Load-bearing glass balustrades held by linear supports secured by clamp-type base mountings, the individual glazing elements of which are connected by a continuous, load-bearing handrail (see example in chapter 6.1) attached to the top of the structure.

- Only LSG shall be used.
- Verified proof of structural characteristics or static structural calculations suitable for verification, as well as a pendulum impact test (test in accordance with DIN EN 12 600 or DIN 18008-4) are required.
- If LSG made of 2 x 10 mm TSG (or 2 x 10 mm HSG) is used, no pendulum impact test is required, provided that the dimensions as stated in Table B are adhered to (design details in accordance with TRAV or DIN 18008-4).
- The thickness of the intermediate PVB/SGP film must be at least 1.52 mm.
- The securing clamps must be at least 100 mm above floor level.

Calculations shall be provided proving that the loads will be distributed via the capping to neighbouring glass sheets in the event of an individual sheet being destroyed. The stresses occurring in the neighbouring glass sheets under the resulting conditions may then increase to 50 % above permissible limits if structural design calculation concept A was applied. If structural design concept B has been applied, this case can be classified as an extraordinary design calculation situation. The destroyed or damaged glass sheet shall be replaced immediately after the incident.

3.2.3 **Category C – Railing and balustrade infills and glass walls with load-distributing cross-bar fitted in front of it**

Definition: Accident-prevention (barrier) glazing which is not intended to distribute capping loads and which corresponds to one of the following groups:

- C1: Railing/balustrade infills secured by linear supports and/or at individual points on at least two opposing sides.
- C2: Vertical glazing beneath a crosswise load-distributing spanning member located at capping level and secured by linear supports on at least two opposing sides.
- C3: Category A type glazing with a load-distributing cross-bar placed in front of it.

- For category C1 and C2 type glazing, the use of TSG is allowed if the sheets are secured by linear supports on all sides. For all other types of supports and for category C3, only LSG may be used unless other statutory construction approval exists.
- Table B contains an overview of possible designs and the proofs required.
- The pendulum impact test is not required if the relevant design specifications and the dimensions and thickness of the glass as stated in Table B or TRAV or in DIN 18008-4 are adhered to.

Alternative measures / protection against glass breakage:

If the proof calculations for category C in accordance with TRAV or DIN 18008-4 are not submitted for accident-prevention (barrier) glazing, then the accident-prevention (barrier) attribute can be achieved by installing adequately sturdy knee-height cross-bars or steel rope of at least 5 mm diameter at a vertical spacing of not more than 35 cm and at an adequate distance in front of the glass infill sheets. Measures to protect against scattering glass splinters shall always be installed above and along the length of walkways, if this is not possible, LSG shall be used.

3.3 **Horizontal glazing**

3.3.1 **Overhead glazing**

AGlass walls tilted at an angle of more than 10° from the vertical are considered to be overhead glazing. Table C contains an overview of possible designs and the proof documentation required.

Only the following glass products may be used:

- LSG made with float glass (PPG)
- LSG made of HSG,
- Wire glass (only for existing components)

In addition to submitting certification of load-bearing capacities, experimental proof of residual load-bearing capacities must be provided or, if this is not possible, a safety net must be hung under the glazing. If the structural design requirements of TRLV or as specified in DIN 18008-2 are met, proof of the residual load-bearing capacities is not required.

The design loads to be assumed are the sheet's own weight and a horizontal pressure corresponding to at least $h_1 = 0.125 \text{ kN/m}^2$ for visible surfaces of up to 4 m above hall floor level or $h_2 = 0.063 \text{ kN/m}^2$ for vertical visible surfaces at more than 4 m above hall floor level.

The sheets must be secured in such a way as to properly safeguard against them slipping out of the mounts and forces which may lift them off the mounts.

The design dimensions of glass sheets mounted at individual points and HSG sheets shall either be calculated according to the rules outlined in chapter 2.3 or they must have general construction approval (abZ).

If, for cleaning purposes, overhead glazing periodically has to support human loads, then such additional loads must be taken into consideration and experimental proof of residual load-bearing capacities must be provided [8]. In such cases a special individual construction approval is always required.

- LSG sheets with an effective span exceeding 1.20 m shall be supported on all sides. The ratio between length and width may not exceed 3 to 1. The overall thickness of the intermediate PVB/SGP films must be at least 0.76 mm. If a sheet is supported on all sides, then a thickness of 0.38 mm is allowed under the condition that the length-to-width ratio is not greater than 3 to 1 and that the effective span in the direction bearing the main load is not greater than 0.8 m.
- The effective span of a wire glass sheet may not exceed 0.7 m, and the glass shall protrude into the supports by at least 15 mm.
- Cutting of recesses or notches in the glass sheets is not allowed.
- Only holes conforming to TRPV and/or DIN 18008-3 are allowed.
- The maximum permissible sag shall not exceed 1/100 of the effective span between the closer supports of the sheet.

3.3.2 **Glazing designed to support human loads**

This kind of glazing is specifically intended to be subjected to persons walking over it, e. g. stairs, platforms, landings and cat-walks. The design and proof calculations shall take both dead loads (own weight) and the working loads into account. In addition, proof of impact resistance and residual load-bearing capacity shall be provided.

Proof of impact resistance and residual load-bearing capacities as a result of component tests must be submitted. The requirements are specified in [8] and in DIN 18008-5.

For glazing mounted in linear supports at all four edges and an assumed working load of not more than 5.0 kN/m² for design calculations, proof of impact resistance and residual load-bearing capacity is deemed to have been provided if the sheets conform to the dimensions listed in Table 3.

Table 3: Glazing mounted in linear supports at all four edges and intended to support human loads, with proven impact resistance and residual load-bearing capacity.

max. length h [mm]	max. width [mm]	LSG structure [mm] (top /*/ centre /*/ bottom)	Min. supporting surface depth [mm]
1500	400	8 HSG /*/ 10 Float /*/ 10 Float	30
1500	750	8 HSG /*/ 12 Float /*/ 12 Float	30
1500	1250	8 HSG /*/ 10 HSG /*/ 10 HSG	35
1250	1500	8 HSG /*/ 12 HSG /*/ 12 HSG	35
1500	1400	8 HSG /*/ 15 Float /*/ 15 Float	35
2000			

/*/ = 1.52 mm PVB or SGP (SentryGlas® plus) intermediate film layer

Information sheet

“Glass and acrylic glass” 2017 (continued)

Glazing designed to support human loads may be secured by linear supports or at individual points. It must be made of LSG consisting of at least three layers of TSG and/or HSG/float glass. From the point of view of impact resistance, the use of TSG or HSG for the top layer is recommended. This surface must possess non-slip characteristics in accordance with DIN 51097. In order to achieve the required residual load-bearing capacity, the two lower layers will normally be made of float glass or HSG.

Glazing, mountings and supporting structure must be designed and their dimensions calculated to withstand the load of their own combined weight (dead load) as well as intended human (working) loads in accordance with the chosen design calculation concept and all relevant and applicable standards.

Design calculation concept	A (TRLV)	B (DIN 18008-5)
Working surface load q_k , depending on usage category	C1: 3.0 kN/m ² C3, T2: 5.0 kN/m ²	C1: 3.0 kN/m ² C3, T2: 5,0 kN/m ²
Point load Q_k , as an additional changing load parameter to be investigated	C1: 4.0 kN C3: 4.0 kN / T2: 2.0 kN	C1: 4.0 kN C3: 4.0 kN / T2: 2.0 kN
Application area of point load	100 x 100 mm	50 x 50 mm
Inclusion of top sheet in structural static calculations allowed	no	only for constant design situation and for temporary design situation
Proof calculation for situation with broken top sheet (i.e. only the two lower sheets still bear the load)	standard proof	proof for an extraordinary design load calculation situation
Standards relating to the action of loads	DIN EN 1991-1-1 DIN EN 1991-1-1 /NA	DIN EN 1991-1-1 DIN EN 1991-1-1 /NA
Max. sag / flexure with 3 load-bearing sheets	l/200	l/200
DMax. sag / flexure with 2 load-bearing sheets	l/100	l/100

In the case of stairways the construction/design must guarantee sufficient distribution of loads. Stairs on stand structures shall always be classified with usage category T2.

4. Approval procedures

4.1 Basics

If a glass component and its glass products conform to the technical building regulations outlined in chapter 2.3 and to generally accepted technical principles, then it shall be sufficient to submit the verified structural calculations and the verified plans, following which construction approval will be granted. In addition, the construction work on site will be checked and the results subjected to an approval inspection. If additional components are installed for which statutory construction approval, a statutory construction test report or type approval are required, then these documents are to be submitted together with the structural calculations.

If a glass component or parts of this component do not conform to the construction engineering regulations and generally accepted technical principles outlined in chapter 2.3, and if no statutory construction approval or statutory construction test certificate can be produced, then an individual construction approval (Zustimmung im Einzelfall – ZiE) shall be required. An **Installation Approval for a Specific Case** may be granted instead of the individual construction approval if glass is used only within the rules and limitations described in this information sheet.

4.2 Installation approval for a specific case

This approval procedure is similar to the procedure for obtaining individual construction approval. If an Installation Approval for a Specific Case has been granted once for a particular construction/design and type of usage, then the trade fair companies in question will accept this for an identical design serving an identical purpose. Nevertheless, a new application for construction work approval and approval inspection shall be submitted for each repeated case. The test report, all certificates and approvals, design details, as well as glass dimensions and thicknesses must be submitted with the application.

Glass components requiring approval and which require type 3 proof documentation are listed in column 14 of Tables A, B and C. Installation approvals for specific cases cannot be granted at short notice, as they require a considerable period of time for processing. Applications for these should therefore be submitted at least 6 weeks before the commencement of construction.

Prior to conducting component tests, it is advisable to contact the relevant trade fair company in good time in order to coordinate procedures and intended testing methods. Normally, component testing requirements stipulate inclusion of parts of the glass component's actual substructure in order to simulate realistic loads.

The procedure for obtaining an Installation Approval for a Specific Case is as follows:

- The structural calculations and the required certificates confirming the identity of the product(s) (glass manufacturer/processing company's factory certificates) must be verified and checked by a publicly certified structural building surveyor and tester (in the field of steel, concrete and brick construction/engineering).

- The surveyor shall confirm that there are no objections with regard to the design's suitability for use. It is his responsibility to decide on the necessity of additional testing of materials, impact resistance and whether further proof of residual load-bearing capacities must be obtained. The test report must be submitted to the trade fair company along with the other application documents requesting construction work permit (construction permit) and subsequent monitoring of the stand construction work and stand approval inspection.

- Final approval will be granted on location following an inspection to confirm that the construction/design on site conforms to the previously inspected documents. The engineer carrying out the monitoring and inspection acts on behalf of the trade fair company.

Recommended institutes for testing components used in glass construction/design:

Technische Universität Dresden,
Institut für Baukonstruktionen (Beyer-Bau), Prof. Dr.-Ing. Weller
George-Bähr-Straße 1, 01069 Dresden

Institut für Massivbau
Prof. Dr.-Ing. Marx, Leibnitz-Universität Hannover
Appelstraße 9a, 30167 Hannover

RWTH Aachen
Lehrstuhl für Stahlbau, Prof. Dr.-Ing. Feldmann
Mies-van-der-Rohe-Straße 1, 52074 Aachen

FMPA Baden-Württemberg
FB 2, Abt. 21, Referat 214
Pfaffenwaldring 4, 70569 Stuttgart (Vaihingen)

FH München
Labor für Stahl- und Leichtmetallbau, Prof. Dr.-Ing. Bucak
Karlstraße 6, 80333 München

MFPA Leipzig GmbH
Hans-Weigel-Straße 2B, 04319 Leipzig

Materialprüfanstalt für das Bauwesen Braunschweig
Beethovenstraße 52, 38106 Braunschweig

MPA Darmstadt
Grafenstraße 2, 64283 Darmstadt

Universität Karlsruhe
Versuchsanstalt für Stahl, Holz und Steine
Prof. Dr.-Ing. Ummenhofer
Otto-Amman-Platz 1, 76131 Karlsruhe

TU München
Lehrstuhl für Stahlbau, Prof. Dr.-Ing. Mensinger
Arcisstraße 21, 80333 München

TU Hamburg - Harburg
Institut für Baustatik und Stahlbau, Prof. Dr.-Ing. Starossek
Denickestraße 7, 21073 Hamburg

Information sheet

“Glass and acrylic glass” 2017 (continued)

MPA Nordrhein-Westfalen
 Marsbruchstraße 186, 44287 Dortmund
 TU Darmstadt
 Institut für Werkstoffe und Mechanik im Bauwesen
 Prof. Dr.-Ing. Wörner
 Petersenstraße 12, 64283 Darmstadt
 Friedmann & Kirchner
 Gesellschaft für Material- und Bauteilprüfung
 Große Ahlmühle 7, 76865 Rohrbach
 Institut für Fenstertechnik e.V.
 Theodor-Griehl-Straße 7-9, 83025 Rosenheim

5. Notes on design and design calculations

- Glass is a brittle material, any failure of which will occur spontaneously and without warning.
 - Glass is sensitive to blows with hard, pointed objects.
- These properties lead to the following guideline notes:
- Proof calculations for the load-bearing capacity of structural glass not only take into consideration the unbroken glass but always include an investigation of the broken or partially broken glass (proof of residual load-bearing capacity).
 - The support design must ensure that glass sheets are not subjected to pressure or stresses by the supports.
 - Direct glass-to-glass contact and contact between glasses and other hard materials (e.g. metal) shall be prevented at all times, whereby the effects of load and temperature fluctuations have to be taken into account.
 - The minimum supporting depths of glass sheets (“glass insertion depth”) on their respective support sections as well as the allowable sheet and supporting beam sections as specified in the standards listed in chapter 2.3 for the selected design calculation concept must be adhered to.
 - After glazing has been installed, the markings identifying the individual type of glass sheet used (e.g. TSG, HSG) must be durable and legible at all times. In the case of LSG glazing, a section of the edge must be left free for inspection purposes (to check the number of glass sheets, thickness, interlayer films) until the construction has been approved. If required, a manufacturer’s certificate shall be submitted as well.
 - The edges of glass sheets must be finished or protected in such a way as to exclude any possibility of injury.
 - In the case of TSG, HSG, or LSG glazing manufactured from sheets of TSG or HSG, subsequent reworking of the finished product such as cutting out sections or drilling holes is not possible.
 - Sheets intended to bear human loads must have a durable non-slip surface finish.
 - Load-bearing adhesive joints may only be used if a general construction approval (abZ) has been granted for the entire adhesive system (i. e. the glass, adhesive and metal combination), and under the condition that the joint is made exactly as described in the approval documents.
 - The rules described in chapter 2.3 do not yet make allowance for applying more favourable assumptions of the joint effect of the intermediate film layers in LSG and therefore an Installation Approval for the Specific Case has to be applied for if these assumptions are used in calculations. Trade publications [18] contain information on suitable calculation assumptions to account for the joint effects in LSG. This may possibly be useful for LSG in which SGP is used.

6. Examples of structures (barriers) designed to prevent falls

All possible dimensions, types of glass, thicknesses and the necessary proof documents are summarised in Table B.

6.1 Category B

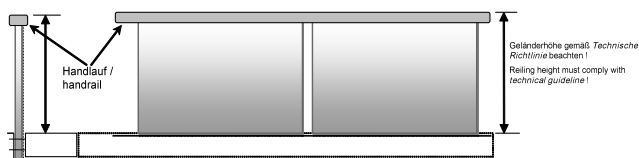

Note: If LSG made of 10 mm TSG + 1.52 mm PVB/SGP + 10 mm TSG or of 10 mm HSG + 1.52 mm PVB/SGP + 10 mm HSG in the dimensions as stated in Table B is used, only static structural proof calculations are required.

As specified in TRAV or DIN 18008-4, this also applies to parallelogram-shaped balustrades.

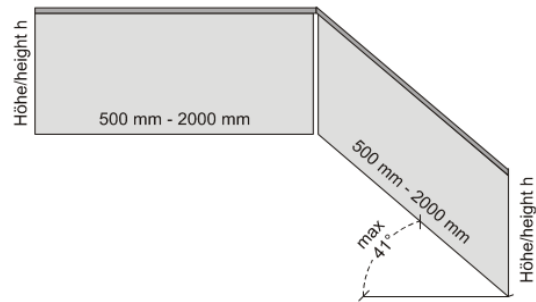

6.2 Category C1

6.2.1 Railing infills secured vertically on 2 sides

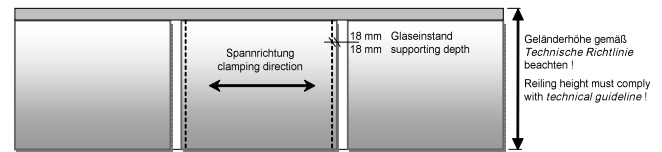

Note: If the types of glass and the dimensions listed in Table B are used, only static structural proof calculations are required.

6.2.2 Railing infills secured horizontally on 2 edges

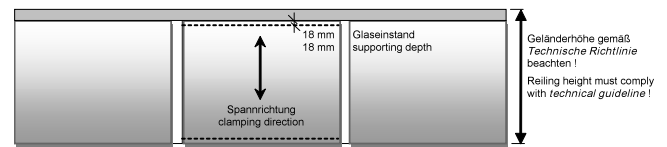

Note: If the types of glass and the dimensions listed in Table B are used, only static structural proof calculations are required.

6.2.3 Railing infills secured on 4 sides

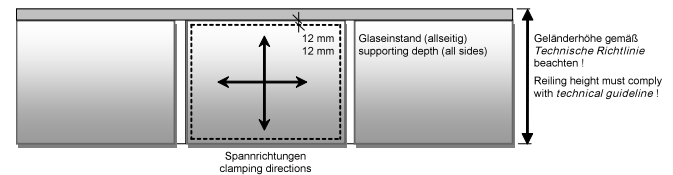

Note: If the types of glass and the dimensions listed in Table B are used, only static structural proof calculations are required.

6.2.4 Glazing secured at individual points by means of drilled anchorage points (design specifications in accordance with TRAV and/or DIN 18008-4)

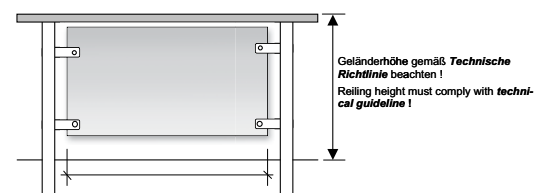

Note: If the types of glass and the dimensions listed in Table B are used, only static structural proof calculations are required.

In accordance with Appendix D of TRAV 2003 and DIN 18008-4, the rules for Categories C1 and C2 also apply to parallelogram-shaped balustrades.

Category C1

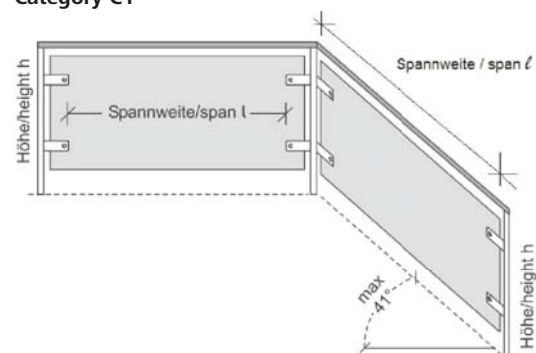

Information sheet

“Glass and acrylic glass” 2017 (continued)

Category C2

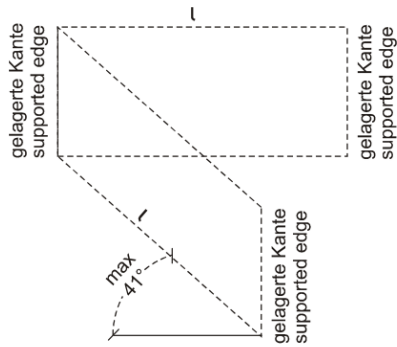

6.2.5 Point mounting with lateral clamps and anti-slip grips

- Designs that have a general construction approval (abZ) shall be used in accordance with.
- For all systems that have not been granted general construction approval, a pendulum impact test is required. Minimum requirement: LSG comprising 6 mm TSG + 1.52 mm PVB + 6 mm TSG or 6mm HSG + 1.52 mm PVB + 6 mm HSG shall be used.

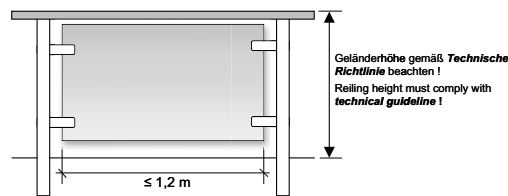

6.2.6 Point mounting with clamps at top and bottom

- System designs that have a general construction approval (abZ) shall be used in accordance with the specifications in the approval documents.
- For all systems that have not been granted general building approval, a pendulum impact test is required. Minimum requirement: LSG comprising 6 mm TSG + 1.52 mm PVB + 6 mm TSG or 6mm HSG + 1.52 mm PVB + 6 mm HSG shall be used.

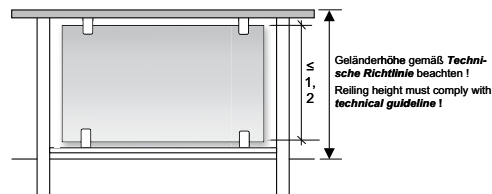

6.3 Balustrade with horizontal bars (protection against falling is provided solely by sufficiently strong handrails and knee-height bars)



The type of glass used shall be selected from Table A, glazing not intended to protect against falls. The spacing between horizontal bars should not exceed approx. 35 cm.

7. Construction engineering regulations, generally accepted rules of engineering and references

- [1] WWörner J.-D., Schneider J., Fink A.: title “Glasbau: Grundlagen, Berechnung, Construction”, published by Springer-Verlag, Berlin Heidelberg; 2001
- [2] Kuhlmann U.: Stahlbau Kalender. Published by Ernst & Sohn Verlag für Architektur und technische Wissenschaften GmbH, Berlin, 1999
- [3] Sedlacek S., Blank K., Laufs W., Güssen J.: title “Glas im Konstruktiven Ingenieurbau”. (1. Aufl.) Ernst & Sohn Verlag für Architektur und technische Wissenschaften GmbH, Berlin, 1999
- [4] Siebert G.: title “Entwurf und Bemessung von tragenden Bauteilen aus Glas”. Published by Ernst & Sohn Verlag für Architektur und technische Wissenschaften GmbH, Berlin, 2001
- [5] Technische Regeln für die Verwendung von linienförmig gelagerten Verglasungen [Technical rules for the use of glazing with linear supports] (TRLV) (final version of August 2006) DIBT

- [6] Technische Regeln für die Verwendung von absturzsichernden Verglasungen [Technical rules for the use of accident-prevention (barrier) glazing] (TRAV), (final version of January 2003)
- [7] Landesgewerbeamt Baden-Württemberg, Landesstelle für Bautechnik, Merkblatt G 2, Zusammenfassung der wesentlichen Anforderungen an zustimmungspflichtige Vertikalverglasungen (Fassung 28.7.1999)
- [8] Communications (Mitteilungen) of DIBt no. 2 / 2001: Anforderungen an begehbare Verglasungen; Empfehlungen für das Zustimmungs-verfahren - Fassung März 2000 -, Berlin (Requirements on glazing intended to be walked on, recommendations for approval procedures Version of March 200 – Berlin)
- [9] Wörner, J.-D; Schneider J.: Closing report on experiments and calculations to determine the dynamic stresses on glass as a result of a light impact, Fraunhofer IRB Verlag Stuttgart 2000, Booklet T 2935
- [10] Völkel, G.E.; Rück R.: Investigation into panes with linear support on 4 sides when subjected to impact, Fraunhofer IRB Verlag Stuttgart 2000, Booklet T 2915
- [11] Weller, B., Nicklisch, F., Thieme, S. Weimar, T.: Glasbau-Praxis in Beispielen, Konstruktion und Berechnung, Bauwerk-Verlag 2.Aufl. 2010
- [12] DIN 18008-1 (December 2010) Glass in Building - Design and construction rules - Part 1: Terms and general bases
- [13] DIN 18008-2 (December 2010) Glass in Building - Design and construction rules - Part 2: Linearly supported glazings
- [14] DIN 18008-3 (October 2011) – DRAFT– Glass in Building - Design and construction rules - Part 3: Point fixed glazing
- [15] DIN 18008-4 (October 2011) – DRAFT– Glass in Building - Design and construction rules - Part 4: Additional requirements for barrier glazing
- [16] DIN 18008-5 (October 2011) – DRAFT– Glass in Building - Design and construction rules - Part 5: Additional requirements for walk-on glazing
- [17] Technische Regeln für die Bemessung und die Ausführung punktförmig gelagerter Verglasung [Technical rules for the use of glazing with supports at individual points] (TRPV), (final version August 2006), DIBt.
- [18] Wellershof, F.: Bemessungsschubmodule für Verbundglas-scheiben, Stahlbau 76 (März 2007), H.3, pp. 177 188
- [19] Building rules list (see www.dibt.de)
- [20] ETB-Richtlinie: Bauteile, die gegen Absturz sichern (June 1985) (ETAss directive: Building components designed to prevent falls)

8. Abbreviations

abZ	German: Allgemeine bauaufsichtliche Zulassung (general construction approval)
C1, C3	Categories for vertically acting working loads on floors of public meeting spaces in buildings as specified in DIN EN 1991-1-1 / NA
DIBt	Deutsches Institut für Bautechnik (German civil engineering institute)
ESG	German: Einscheiben-Sicherheitsglas (fully-tempered glass / toughened safety glass)
HSG	Heat-strengthened glass
LSG	Laminated safety glass
PPG	Polished plate glass
PVB	polyvinyl butyric (intermediate film material for LSG)
SGP	SentryGlas® plus (intermediate film material for LSG)
SLS	Serviceability limit state
SLS	Serviceability limit state
SPG	German: Spiegelglas (float glass or PPG)
T2	Category for vertically acting working loads on stairs / staircase landings for large traffic loads and escape staircases as specified in DIN EN 1991-1-1 / NA
TRAV	Technische Regeln für die Verwendung von absturzsichernden Verglasungen [Technical rules for the use of accident-prevention (barrier) glazing]
TRLV	Technische Regeln für die Verwendung von linienförmig gelagerten Verglasungen [Technical rules for the use of glazing with linear supports]
TRPV	Technische Regeln für die Bemessung und die Ausführung punktförmig gelagerter Verglasung [Technical rules for the use of glazing with supports at individual points]
TSG	Toughened safety glass
TVG	German: Teilvorgespanntes Glas (heat-strengthened glass)
ULS	Ultimate limit state
VSG	German: Verbund-Sicherheitsglas (laminated safety glass)
ZIE	German: Zustimmung im Einzelfall (individual construction approval)

Information sheet

“Glass and acrylic glass” 2017 (continued)

Table A: Vertical glazing, not intended to prevent falls

1	2	3	4	5	6	7	8	9	10	11	12	13	14	15
Structure type	Character-istic	Structure	Sheet support	Glass type	Allowed, yes/no	Glass thickness in mm	SGP/PVB film thickness	Width in mm	Height in mm	Min. glass insertion depth in mm	Type of proof required	Civil engineering rules		
Type					yes/no	min. max.	min. max.	min. max.	min. max.	min. max.				
Vertical glazing	not intended to prevent falls	Glass wall > 4.0 m above floor level	Linear support on 2 sides	TSG LSG 2 layers Wire glass Acrylic glass	yes yes yes yes						1			
			Linear support on 4 sides	TSG Wire glass Acrylic glass	yes yes yes							1		
	Point supports	Point supports	Point supports	LSG 2 layers Wire glass Acrylic glass	yes yes no						1			
			Point supports	TSG	yes							2.5	A	
	Point supports	Point supports	Point supports	LSG 2 layers Wire glass Acrylic glass	yes yes yes						2	A		
			Point supports	TSG	yes							1	A	
	Point supports	Point supports	Point supports	LSG 2 layers Wire glass Acrylic glass	yes yes yes							2 ¹⁾	A	
			Point supports	TSG	yes							1	A	
	Point supports	Point supports	Point supports	LSG 2 layers Wire glass Acrylic glass	yes yes yes							2, 3, 5 2, 3	C	
			Point supports	TSG	yes							1	C	
Point supports	Point supports	Point supports	Wire glass Acrylic glass	no yes							1			
		Point supports	TSG	yes							1.5			
Point supports	Point supports	Point supports	LSG 2 layers Wire glass Acrylic glass	yes yes yes							1			
		Point supports	TSG	yes							1			
Point supports	Point supports	Point supports	LSG 2 layers Wire glass Acrylic glass	yes yes yes							1			
		Point supports	TSG	yes							1			
Point supports	Point supports	Point supports	LSG 2 layers Wire glass Acrylic glass	yes yes yes							1			
		Point supports	TSG	yes							1.5			
Point supports	Point supports	Point supports	LSG 2 layers Wire glass Acrylic glass	yes yes yes							1			
		Point supports	TSG	yes							1			
Point supports	Point supports	Point supports	LSG 2 layers Wire glass Acrylic glass	yes yes yes							1			
		Point supports	TSG	yes							1			
Point supports	Point supports	Point supports	Wire glass Acrylic glass	no yes							1			
		Point supports	TSG	yes							1			

Proof by:

Civil engineering rules:

As of: 1.12.2012

1: No specific proof

A: TRLV or DIN 18008-1/2

2: Verified static calculations

B: TRAV or DIN 18008-1/2

3: Installation appr. for spec. case

C: TRPV or DIN 18008-3

4: Pendulum impact test

5: Heat soak test

6: Residual load-bearing cap. test

7: Shock impact resistance test

¹⁾ Proof type 2 (verified static design calculations) are not required for sheet areas A ≤ 1.6 m² and d³ 4 mm

Information sheet

"Glass and acrylic glass" 2017 (continued)

Table B: Vertical glazing, intended to prevent falls (barrier glazing)

1	2	3	4	5	6	7	8	9	10	11	12	13	14	15	
Structure type	Character-istic	Structure	Sheet support	Glass type	Allowed, yes/no	Glass thickness in mm	SGP/PVB film thickness	Width in mm	Height in mm	Min. glass insertion depth in mm	Type of proof required	Civil engineering rules			
Vertical glazing	Fall-prevention, barrier (Dh > 1 m)	Glass wall (cat. A as defined in TRAV)	Linear support on 2 sides	TSG	no ²⁾										
			Linear support on 4 sides	LSG 2 layers TSG	yes no ²⁾	2 x 6 Float 2 x 8 Float 2 x 10 Float 2 x 6 Float 2 x 8 Float 2 x 10 Float 2 x 6 Float	0.76 0.76 0.76 0.76 0.76 0.76 0.76	500 500 1200 500 500 1000 300	1000 1000 1000 1000 1000 1200 500	2000 2500 3000 2000 1500 2100 3000	2, 4 2	A, B A, B			
			Point supports	LSG 2 layers LSG 2 layers LSG 2 layers LSG 2 layers	yes yes yes yes	2 x 10 HSG 2 x 8 TSG 2 x 10 TSG 2 x 10 TSG	1.52 1.52 1.52 1.52	1200 ³⁾ 1200 ³⁾ 1600 ³⁾ 1800 ³⁾ 2000 ³⁾					2, 3, 4	B, C B, C B, C B, C B, C	
			Linear clamping at one edge	TSG LSG 2 layers LSG 2 layers	no yes yes	2 x 10 TSG 2 x 10 HSG	0.76 1.52	500 500	2000 2000	900 900	1100 1100	100 100	2 2	A, B A, B	
			Linear support at top and bottom	TSG	no ²⁾	LSG 2 layers	yes	2 x 6 Float 2 x 5 TSG 2 x 8 Float	0.76 0.76 1.52	1000 800 800	500	18 1100 1100	2	A, B	
			Linear support at left and right	TSG	no ²⁾	LSG 2 layers	yes	2 x 6 Float 2 x 6 TSG 2 x 8 Float	0.76 0.76 1.52	800 1100 1100	1000 800 800	18 1100	2	A, B	
			Linear support on 4 sides	TSG LSG 2 layers TSG	yes yes no ²⁾	LSG 2 layers LSG 2 layers	yes yes	2 x 5 Float 2 x 5 TSG	0.76 1.52	500	500	12 12	2, 4 2	A, B	
			Point supports	LSG 2 layers LSG 2 layers LSG 2 layers LSG 2 layers	yes yes yes yes	2 x 6 TSG 2 x 8 TSG 2 x 8 HSG 2 x 6 HSG	1.52 1.52 1.52 1.52	1200 1600 1600 700	700 800 800 700			10 800 800 10	2 2 2	B, C B, C B, C	
			Linear support on 2 sides	TSG	yes	LSG 2 layers	yes	2 x 5 SPG	0.76	500	1000	12	3000	2	A, B
			Linear support on 4 sides	TSG LSG 2 layers	yes yes	LSG 2 layers	yes							2, 3, 4	B, C

Proof by:

- 1: No specific proof
- 2: Verified static calculations
- 3: Installation appr. for spec. case
- 4: Pendulum impact test
- 5: Heat soak test
- 6: Residual load-bearing cap. test
- 7: Shock impact resistance test

Civil engineering rules:

- A: TRLV or DIN 18008-1/2
- B: TRAV or DIN 18008-4
- C: TRPV or DIN 18008-3

As of: 1.12.2012

Note: where decimal fractions are listed in the table, a comma is used instead of a decimal point to permit the same table contents to be used for all language versions.

"If a pendulum impact test, proof type "4", is not specified in column 14, then this advantage is subject to adherence to the limit values stated in columns 7 to 13. Structural designs not listed here will require an Installation Approval for the Specific Case."

- 2) In systems having a valid general statutory construction approval, LSG may be used in accordance with the text of the approval documents.
- 3) The distance between neighbouring point supports in x-direction and in y-direction, respectively.
- 4) Clamped on both faces by circular plates with diameter $d >= 50$ mm, if spacing is greater than 1200 mm, plate diameter shall be $d >= 70$ mm, see DIN 18008-3/4

The use of acrylic glass and wire glass is not allowed for vertical glazing intended to prevent falls (barrier glazing). If the sheets are held in linear supports, LSG made of HSG and with the same specified thicknesses may be used instead of LSG made of float glass.

Information sheet "Glass and acrylic glass" 2017 (continued)

Tabelle C, Horizontalverglasung

1	2	3	4	5	6	7	8	9	10	11	12	13	14	15	
Structure type	Characteristic	Structure	Sheet support	Glass type	Allowed, yes/no	Glass thickness in mm top ¹ / centre ¹ / bottom ¹ ¹ / ¹ = 1,52 mm PVB / SGP	SGP/PVB film thickness	Length in mm min. / max.	Width in mm min. / max.	Min. glass insertion depth in mm	Type of proof required	Civil engineering rules			
Horizontal glazing	Overhead glazing (angled at > 10° to the vertical) ³⁾	Linear support on 2 sides Linear support on 4 sides Point supports Linear support on 2 sides Linear support on 4 sides Installed at height < 20 cm	Linear support on 2 sides Linear support on 4 sides Point supports Linear support on 2 sides Linear support on 4 sides Installed at height < 20 cm	TSG	no										
				LSG 2 layers	yes			1200 ⁴⁾				2 ⁹⁾	A		
				Wire glass	yes			700 ⁴⁾				15	2	A	
				TSG	no										
				LSG 2 layers	yes			700 ⁴⁾				15	2	A	
				TSG	no										
				LSG 2 layers	yes			1,52						2, 3, 6 ⁶⁾	C
				Wire glass	yes										
				TSG	no								30	2 ⁹⁾	A
				LSG 2 layers	yes										
Horizontal glazing	Glazing capable of supporting persons (to be walked on)	Linear support on 2 sides Linear support on 4 sides Point supports Linear support on 2 sides Linear support on 4 sides Installed at height < 20 cm	Linear support on 2 sides Linear support on 4 sides Point supports Linear support on 2 sides Linear support on 4 sides Installed at height < 20 cm	LSG 2 layers	no										
				VSG 3-lagig	yes			1500			30				
				VSG 3-lagig	yes			1500				30			
				VSG 3-lagig	yes			1250				35			
				VSG 3-lagig	yes			1500				35		A, D	
				VSG 3-lagig	yes			2000				35			
				VSG 3-lagig	yes			1,52						2 ⁹⁾ , 3, 7	A, D
				Wire glass	yes										
				TSG	no										
				LSG 2 layers	yes										
Horizontal glazing	Glazing capable of supporting persons (to be walked on)	Linear support on 2 sides Linear support on 4 sides Point supports Linear support on 2 sides Linear support on 4 sides Installed at height < 20 cm	Linear support on 2 sides Linear support on 4 sides Point supports Linear support on 2 sides Linear support on 4 sides Installed at height < 20 cm	VSG 3-lagig	no										
				Wire glass	yes										
				TSG	no										
				LSG 2 layers	yes										
				VSG 3-lagig	yes										
				Wire glass	yes										
				TSG	no										
				LSG 2 layers	yes										
				VSG 3-lagig	yes										
				Wire glass	yes										
Horizontal glazing	Civil engineering rules:	Civil engineering rules: A: TRLV or DIN 18008-1/2 B: TRAV or DIN 18008-4 C: TRPV or DIN 18008-3 D: DIN 18008-5	Civil engineering rules: A: TRLV or DIN 18008-1/2 B: TRAV or DIN 18008-4 C: TRPV or DIN 18008-3 D: DIN 18008-5	TSG	no										
				LSG 2 layers	no										
				VSG 3-lagig	yes										
				Wire glass	yes										
				TSG	no										
				LSG 2 layers	yes										
				VSG 3-lagig	yes										
				Wire glass	yes										
				TSG	no										
				LSG 2 layers	yes										

As of: 1.12.2012

Note: where decimal fractions are listed in the table, a comma is used instead of a decimal point to permit the same table contents to be used for all language versions.

3) Overhead glazing that has to be capable of supporting human loads to permit cleaning is subject to a special approval procedure.

4) The data apply to the smaller distance between supports (support direction).

5) If HSG which has not received general statutory construction approval (abZ) is used, an additional Installation Approval for the Specific Case is required.

6) If glass type/support type combination systems which have been granted a general statutory construction approval (abZ) are used, the Installation Approval for the Specific Case is not required.

The use of acrylic glass for horizontal glazing is not allowed. However, exceptions may be possible if the trade-fair company has no objections with regard to fire prevention/protection and structural stability.

Instruction Sheet

“Suspension points, trusses and lifting equipment” 2017

The suspension of objects from the hall ceiling, the provision of suspension points and the modification of suspension constructions are carried out exclusively by NürnbergMesse through its appointed ServicePartners. Suspension points must be ordered in writing from the Exhibition Services Dept. of NürnbergMesse using Form S2.15. The construction to be suspended must be located within the stand boundaries. The maximum vertical structural load capacity of each suspension point on the ceiling construction is 25 kg for halls 1, 2, 3, 4, 5, 6, 7, 8, 9, 10 and 12. In halls **3A, 4A, 7A and 11**, the **maximum vertical structural load capacity is 250 kg (2.5 KN)**. Higher loads are only possible on request via the Facility & Event Services Department and after structural inspection by an engineer appointed by NürnbergMesse.

The exhibitor or client will be charged for the cost of such a structural inspection.

NürnbergMesse reserves the right to require the installation of load measuring systems in the case of statically indeterminate systems. The load measuring systems are to be supplied, installed and operated exclusively by SAG GmbH. The costs of the load measuring systems will be billed to the ordering party. We would like to advise that the use of load cells can reduce the maximum suspension height by up to 50 cm.

The following types of suspension are not permitted for safety reasons:

- Suspended constructions with a rigid or non-positive connection to the hall floor (see Figures 1 and 2)
- Suspension points used for securing stand components or exhibits (stand components or exhibits must stand securely on their own, see Figures 3 and 4)
- Suspension from exhibits (see Figures 5 and 6)
- The use of bridle suspension points is not permitted on the NürnbergMesse site (see Figure 7)

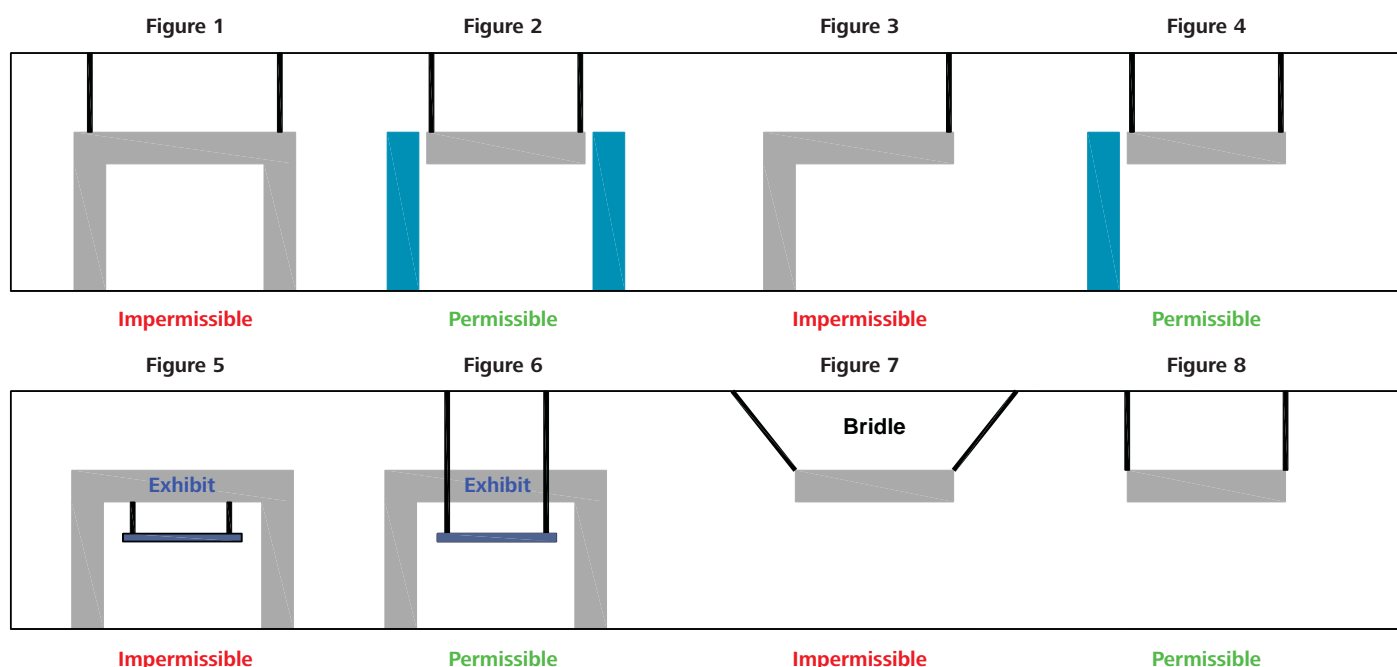

The use of lifting equipment (electric chain hoists, manual chain hoists, sling hoists) is only possible in halls 3A, 4A, 7A, 11 and NCC Ost and must be agreed with NürnbergMesse/Facility & Event Services.

The provision and use of attachment gear, load-bearing equipment, lifting equipment, load-bearing lines, fasteners, rope terminations, secondary safety equipment and equipotential bonding must comply with the relevant safety regulations and the recognized rules of engineering. The following regulations issued by the various German associations apply:

DGUV Regulation 1 (formerly BGV A1) – Grundsätze der Prävention,
 DGUV Regulation 17 (formerly BGV C1) – Staging and Production Facilities for the Entertainment Industry,
 DGUV Regulation 54 (formerly BGV D8) – Winches, Lifting and Hoisting Equipment,
 DGUV Information 215-310 (formerly BGI 810) Guide to Safety at Productions and Events,
 DGUV Information 215-313 (formerly BGI 810-3) Safety at Productions and Events – Loads Suspended above Persons
 DGUV Information 215-314 (formerly BGI 810-4) Spotlights
 DGUV Information 215-315 (formerly BGI 810-5) Special Stage Effects and Operations

IGVV SQP1 “Trusses”
 IGVV SQP2 “Electric Chain Hoists”,
 IGVV SQP1 “Event Electrician”,
 IGVV SQP2 “Event Rigging Expert”

Bavarian Venue Regulations (German: Bay. VStättV)

The following information on attachment gear, load-bearing equipment, lifting equipment, fasteners, rope terminations and secondary safety components is intended as a guide and is not exhaustive.

Attachment gear:

The maximum load on ropes and slings must not exceed one-tenth of the minimum breaking load. The maximum load for other attachment gear is half the manufacturer’s specified working load limit (WLL). Any dynamic forces occurring must be given special consideration (dynamic factor).

The edge radius for attaching loads must be greater than the nominal diameter of the attachment gear (rope, webbing sling and round sling). No further load reduction is necessary for an edge radius of more than three times the nominal diameter of the attachment gear.

The heat resistance of attachment gear varies. Webbing slings and round slings made of man-made fibers (PA, PES) and wire ropes with fiber cores (ferrule and thimble) are only to be used up to 100 °C and are not suitable for use close to spotlights. Webbing slings and round slings made of polypropylene (PP) are only designed for use up to 80 °C and therefore even less suitable.

Wire ropes with steel cores (ferrule and thimble) are suitable for use at temperatures up to 150 °C.

“Suspension points, trusses and lifting equipment” 2017

(continued)

Permissible attachment gear:

- Attachment ropes of steel wire with fiber or steel cores, ferrules and thimble rope terminations, and rope grade 1960 (corresponds to a minimum rated wire strength of 1770 N/mm²) to DIN EN 12385-4, Table 7 (rope class 6 x 19 for ropes ≥ 6 mm), Table 12 (rope class 6 x 19 M for ropes of 3 mm to 5 mm), DIN EN 13414-1, Table 3 and 4 (ropes ≥ 8 mm)
- Rope terminations must comply with DIN EN 13411-1 (thimbles) and DIN EN 13411-3 (ferrules)
- Short-link sling chains of quality grade 8 (DIN 5688-3:2007-3) or higher, with a breaking strength ≥ 20 %
- Webbing slings and round slings made of man-made fibers to DIN EN 1492-1, DIN EN 1492-2 with marking and using a secondary safety component comprising a steel rope with thimble, ferrule and fastener (to DIN 56927)
- Wire rope round sling with sheath of man-made fibers (“steelflex”)
- Aluminum or steel clips and truss adapter approved for the respective trusses (accessory), with marking (indicating load capacity and safety coefficient)

Impermissible attachment gear:

- Wire ropes not conforming to the above requirements
- Wire ropes with sheath (sheath > 1/3 of rope length)
- Long-link sling chains (inside length of chain link (pitch) > 3 x nominal diameter of chain material)
- Untested short-link sling chains or short-link lifting equipment chains (these must not be used as sling chains, as they have a breaking strength of only 5 to 15 %)
- Cable ties, pipe clips or perforated tape without the use of a secondary safety component comprising a steel wire rope with thimble, ferrule and fastener (DIN 56927)
- Webbing slings and round slings made of man-made fibers, without marking and indication of load capacity

- Webbing slings and round slings made of man-made fibers to DIN EN 1492-1, DIN EN 1492-2 with marking and indication of load capacity, BUT without the use of a secondary safety component comprising a steel wire rope with thimble, ferrule and fastener (DIN 56927)
- Damaged attachment gear (e.g. kinked ropes, slings with damaged sheath and sling without recognizable marking)
- One-sided load pickups at trusses with two upper straps (e.g. four-point trusses) are not permitted since this could cause an additional loading of the trusses through torsion. Deviations from this must be accompanied by a structural loading certificate and agreed upon beforehand with NürnbergMesse (Exhibition Technology Department)

Permissible load-bearing equipment:

- Aluminum trusses to DIN EN 1999-1-1, DIN EN 1999-1-1/NA, GUV-I 8634/IGVV SQP1 “Trusses”
- Steel trusses to DIN EN 1090-2, DIN 18800-7, GUV-I 8634/IGVV SQP1 “Trusses”

Impermissible load-bearing equipment:

- Trusses not conforming to the requirements of GUV-I 8634/SQP1 “Trusses” and DIN EN 1999-1-1, DIN EN 1999-1-1/NA, DIN EN 1090-2, DIN 18800-7
- Trusses without a structural test certificate
- Trusses without marking
- Trusses those are no longer safe for use, i.e. damaged or worn
- Trusses without end struts, if the framework is ignored
- Trusses not used for their intended purpose, e.g. screwed to stand walls, on stand walls, frames, truss tower with base plates that are too small and/or too little ballasting
- Truss systems put together out of different types (manufacturers, versions, models)
- Variably bendable truss corners (“book corners”) should generally be load-free

Permissible and impermissible positions for installing trusses without additional structural safety certificate:

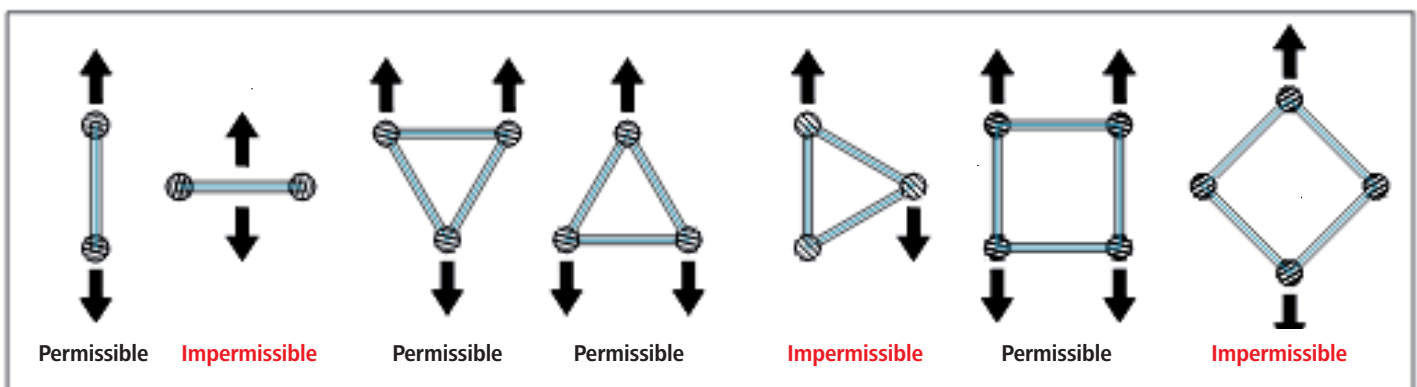

Equipotential bonding of truss systems¹

Truss systems that may carry hazardous contact voltages in the event of a fault must be incorporated in a common equipotential bonding system. This applies to all elements of electrically conductive material on which electrical equipment is installed or mounted or over which lines and cables are routed which could come into contact with metal parts in the event of damage. Connection to the equipotential bonding system can be made using clips, pipe clamps, screwed fasteners or special single-pole plug-in

connectors with locking device. The common equipotential bonding is to be connected to the ground conductor of the mains supply network. Suitable conductor cross-sections are 16 mm² Cu for conductor lengths of up to 50 meters and 25 mm² Cu for conductor lengths of up to 100 meters.

¹ IGVV SQP1 Provision and Use of Truss Systems, 5.3 Installation of Trusses, Equipotential Bonding on 2017 Trusses

Instruction Sheet

“Suspension points, trusses and lifting equipment” 2017

(continued)

Permissible lifting equipment:

- **C 1 hoist** (Point hoist to DGUV Regulation 17 (formerly BGV C1), IGWW SQP2)
Nominal load as specified by manufacturer
- **D 8 hoist** (Electric chain hoist to DGUV Regulation 54 (formerly BGV D8) with secondary safety component for bypassing the electric chain hoist)
MOVING OR HOLDING LOADS ABOVE PERSONS WITHOUT A SAFETY DEVICE IS PROHIBITED!
Nominal load as specified by manufacturer
- **D 8 Plus hoist** (Electric chain hoist with secondary safety component/ second brake to DGUV Regulation 54 (formerly BGV D8) with special features to hold loads in place above persons without secondary safety component – IGWW SQP2)
MOVING LOADS ABOVE PERSONS IS PROHIBITED!
Nominal load as specified by manufacturer

Use of lifting equipment

The use of lifting equipment (electric chain hoists, manual chain hoists, etc.) is only possible in halls 3A, 4A, 7A and 11 requires prior approval by NürnbergMesse.

The use of lifting equipment (electric chain hoists, manual chain hoists, etc.) in halls 1, 2, 3, 4, 5, 6, 7, 8, 9, 10 and 12 is strictly prohibited!

The use of lifting equipment is governed by the requirements and implementation instructions of DGUV Regulation 17 (formerly BGV C1/GUV C1), DGUV Information Sheet 215-313 (formerly BGI 810-3) and the industry standard SQ .

A suitable rope termination (e.g. ring or rope socket) must be provided. Wire rope fasteners (holders, sliders) are only designed for static loads and must not be used in conjunction with lifting gear.

The use of lifting gear must be advised when ordering suspension points!

Electric chain hoists – general information

Electric chain hoists may only be used in halls with heavy duty suspension devices (halls 3A, 4A, 7A and 11).

The use of this lifting gear is subject to the Requirements for Electric Chain Hoists in Event Technology (IGVV SQ P2).

The dead weight of the electric chain hoists and dynamic coefficients must be taken account of in the load plan so as not to overload the slinging points.

The contractor must subject the hoists to an annual inspection. The test certification mark must be affixed to a visible location on the lifting equipment and the test documentation has to be available on site at all times.

This inspection does not replace the inspection by an officially appointed expert every four years.

Manual chain hoists – general information

Manual chain hoists may only be used in conjunction with heavy-duty suspension devices (hall 3A, 4A, 7A and 11).

Manual chain hoists may only be used in the case of statically determinate systems, i.e. a line load on two hoists or a distributed load on three hoists. The use of manual chain hoists for complex systems is not admissible.

The carrying and load hook of the hoist must be in a perpendicular straight line above the centre of gravity of the load. Winding round the load with the chain (carrier) or guiding the load chain over corners is not admissible. Loads must always be moved with all attached manual chain hoists at the same time, i.e. there must be as many people lifting at the same time as there are manual chain hoists in use. It must be ensured that the lifting and lowering processes are uniform.

The dead weight of the manual chain hoists and dynamic coefficients must be taken account of in the load plan so as not to overload the slinging points.

Impermissible lifting equipment:

- Electric chain hoists to DGUV Regulation 54 (formerly BGV D8), without secondary safety component
- Electric chain hoists to DGUV Regulation 54 (formerly BGV D8) with inadequately rated secondary safety component (see Permissible secondary safety components)
- Untested electric chain hoists or electric chain hoists without test certificates (annual inspection; for C1 hoists: plus expert inspection every 4 years)
- Electric chain hoists showing obvious signs of damage
- Electric chain hoists not used for their intended purpose (see IGWW SQP2, e.g. stage use of an electric chain hoist to DGUV Regulation 54 (formerly BGV D8))

Permissible fasteners:

The nominal load is half the manufacturer's specified load-bearing capacity, maximum one-tenth of the minimum breaking load.

- Shackles, straight and curved, grade 6, to DIN EN 13889 with marking, with type X threaded bolt (with hexagonal head, hexagonal splint nut) if used with dynamic loads (e.g. for suspension of loudspeakers)
- High-strength shackle, grade 8, to DIN EN 1677-1
- Quick link for operation of lifting equipment, non-standard (safety factor 5), marked with load-bearing capacity
- Quick link for event equipment (safety factor 10) to DIN 56927 with marking
- Turnbuckles with closed eyes to DIN 1480, marked with load-bearing capacity, only with safety splint and safety nut if used with dynamic loads (e.g. for suspension of loudspeakers)
- Closed O-ring marked with load-bearing capacity, or with manufacturer's data sheet
- Shortening clutch with safety element to prevent unintentional unhooking, e.g. locking pins

Impermissible fasteners:

- Carabiners with/without screw lock
- Open hooks
- Open turnbuckles to DIN 1480
- Quick link with lock nut, not marked with load-bearing capacity
- Tensioning sets as connection between two truss parts
- Shackles to DIN 82101 (have a working coefficient of only 3)
- Shortening clutch without safety element to prevent unintentional unhooking, e.g. locking pins
- Other fasteners without marking/indication of load-bearing capacity/manufacturer's data sheet

Permissible rope terminations:

- Thimble to DIN EN 13411-1 and ferrules to DIN EN 13411-3
- Rope locks (straight) to DIN EN 13411-7, for dynamic loads (e.g. suspension of loudspeakers) only with rope clamp (frog) to DIN EN 13411-5

Impermissible rope terminations:

- Rope clamps (frogs) to former DIN 1141
- Rope clamps (frogs) to former DIN 741

“Suspension points, trusses and lifting equipment” 2017

(continued)

Secondary safety components:

A secondary safety component usually consists of a wire rope, rope termination and fastener to **DIN 56927**. The drop distance should be as short as possible, ideally zero.

This is best achieved with a safety rope together with a grade 8 shortening clutch equipped with a safety element to prevent unintentional unhooking (drop distance \leq length of one chain link (pitch)).

Only quick links to DIN 56927, grade 8 high-strength shackles to DIN EN 1677-1 and, with limitations, carabiners to DIN 56927 may be used as fasteners for a secondary safety component.

If secondary safety components with a larger drop distance than one chain pitch are used, a structural certificate may be requested for the pulse load of all components of the secondary safety component, attachment gear, load-bearing lines, fasteners and load-bearing equipment.

Permissible secondary safety components:

- Wire rope of steel wire with fiber core, ferrule sling and thimble as rope termination, rope grade 1960, to DIN EN 12385-4, Table 7 (rope class 6 x 19 for ropes \geq 6 mm), Table 12 (rope class 6 x 19 M for ropes of 3 mm to 5 mm), DIN EN 13414-1, Table 3, or to former DIN 3060 (round-stranded rope 6 x 19 standard)
- Rope terminations must comply with DIN EN 13411-1 (thimbles) and DIN EN 13411-3 (ferrules)
- Fasteners conforming to the above standards

Impermissible secondary safety components:

- Wire ropes not conforming to the above requirements
- Inadequately rated wire ropes (see DIN 56927, DGUV Information 215-313 (formerly BGI 810-3))
- Fasteners not conforming to the above requirements
- Inadequately rated fasteners (see DIN 56927)
- Rope terminations not conforming to the above requirements (e.g. rope locks)

The operation of laser devices and equipment is subject to notification. The form "Registration of a laser device" form must be returned to NürnbergMesse at least 6 weeks before the start of construction.

According to DGUV Regulation 2 "Laser radiation", notice of the operation of laser systems must be submitted to the Berufsgenossenschaft [Trade Association] and the authority responsible for safety at work (Industrial Trade Inspectorate, Regierungsbezirk Mittelfranken):

Gewerbeaufsichtsamt Nürnberg
 Roonstrasse 20
 90429 Nürnberg
 Tel +49 (0) 9 11. 9 28-0
 Fax +49 (0) 9 11. 9 28-29 99
 www.gaa-n.bayern.de

A trained **laser protection officer** (according to IEC/EN 60825; 2006/25 EC/OStrV) must be present on the stand if the laser or LED devices are classified in normal operation and/or during erection in **classes 3R, 3B or 4** (according to DIN EN 60825-1).

General:

Laser equipment (according to DIN EN 60825-1) produces extremely intensive radiation, which is concentrated into a high energy density by optical systems. The energy density is only slightly reduced even at long range. If laser radiation strikes the human eye, this can cause irreparable damage to the retina.

The following instructions must therefore be observed when setting up laser/LED equipment at trade fairs, exhibitions and shows:

1. Only lasers that transmit **visible light** (wavelength 400 to 700 nm) may be used. The output power must be limited to the extent essential for the purpose.
2. Laser equipment must be assigned to a class (1-4) in accordance with DIN EN 60825-1 and marked accordingly.

Class 1	Safe for the human eye. Output power: <0.4 mW
Class 1M	Safe as long as no optical instruments (lenses, etc.) are used. Output power: <0.4 mW
Class 1C	Medical lasers (use and safety measures as per manufacturer's instructions)
Class 2	Safe for the human eye for short periods of exposure to radiation of max. 0.25 s. Output power: <1 mW
Class 2M	Safe for the human eye as long as no optical instruments (lenses, etc.) are used. Output power: <1 mW
Class 3R	The accessible laser radiation is dangerous for the eye. Output power: 1-5 mW
Class 3B	Dangerous for the human eye and in special cases for the skin as well. Output power: 5-500 mW
Class 4	Very dangerous for the human eye and dangerous for the skin. There is also a risk of fire! (See Form P2) Output power: > 500 mW

3. Laser systems must comply with the requirements of the Equipment Safety Act and the generally recognized rules of engineering. These particularly include the Occupational Health and Safety Regulations of the trade associations **DGUV (German Statutory Accident Insurance) Regulation 11 (formerly BGV B2)**, the stipulations of Directive (2006/25 EC/OStrV, TROS Laser, DIN EN 60825-1, DIN EN 122254 and in the case of show lasers, the provisions of DIN 56912. The manufacturer can prove compliance with the safety standards through a test carried out by an approved body.
4. If class **3R, 3B or 4** lasers are used, the beam must be widened by optical instruments to reduce the power density to a safe level in all areas in which people are present. Alternatively, the beam must be routed at a minimum height of 2.7 m above the floor.

Any devices/equipment belonging to classes 3R, 3B or 4 generally have to be inspected on site by a publicly appointed and certified authority and declared safe before being put into operation. A copy of the inspection report has to be submitted to NürnbergMesse.

When adjusting and operating laser equipment, technical or organizational measures must be implemented to ensure that no one is exposed to laser radiation in excess of the maximum admissible limits. A laser safety officer must be nominated by the exhibitor in writing. When demonstrating laser equipment it must be ensured that no uncontrolled reflected radiation can occur and that nobody can access the laser and/or projection area.

5. If individual requirements cannot be complied with, **the following protective measures shall be used:**
 The laser beam shall be permanently installed so that people cannot enter the area of the beam.
 Beams reflected intentionally or unintentionally from reflective surfaces (mirrors, metallic surfaces, glasses, bottles) must not be aimed at areas where people are present. If this cannot be excluded or is accepted during demonstrations, these persons must be provided with suitable tested safety goggles.
 If light effects are used during shows, persons must be prevented from entering the laser projection area. This also applies to areas through which the beam is deflected by reflection equipment.
 No focusing devices are to be present in the laser area.
 Unintentional drifting or deflection of the beam must be prevented by non-combustible barriers.
6. Laser systems must be shielded to ensure that only the useful beam can be transmitted.
7. Laser equipment must be set up in a firm position and secured to prevent movement.
8. Optical equipment, deflection devices, scanners, etc. must be secured to prevent falling or unintentional movement. The measures implemented must comply with the relevant event equipment regulations.
9. Optical equipment intended as attachments for lasers must be marked to indicate any changes caused to the beam data if this equipment is not mounted on the laser equipment itself.
10. The adjustment of the laser system must be checked before each demonstration. If maladjustment is detected, the system must be taken out of operation immediately and repaired by a skilled person.
11. Laser systems, operator consoles and other control equipment must not be accessible for unauthorized persons and it must not be possible for such persons to start the equipment unwittingly (panic button with key).
12. The operating staff must be able to view the complete sphere of action of the laser.
13. If the laser radiation could cause an unintentional fire hazard, this must be notified to NürnbergMesse on Form P2.

For more detailed information please contact our Event Technology Department:
 standgenehmigung@nuernbergmesse.de
 www.nuernbergmesse.de

14. **Laser pointers** with the designation "IIIA", "IIIA" or "3A" under the US ANSI/CDRH rules do not comply with the requirements of valid standard EN 60825-1 and may not be used, since these generally have power outputs > 1 mW.

NürnbergMesse may intervene in the case of violations of these rules and is then entitled to switch off the power supply to the stand or to confiscate and secure the laser devices/equipment (to be returned on the last day of the trade fair when the trade fair is over).

(continued)

For further information, please contact:

- **NürnbergMesse GmbH**
Abteilung Veranstaltungstechnik
Messezentrum
90471 Nürnberg
veranstaltungstechnik@nuernbergmesse.de
www.nuernbergmesse.de
- **Laser experts:**
 - TÜV Süddeutschland**
Bau und Betrieb GmbH
Westendstrasse 199
80686 München
Tel +49 (0) 89. 57 91-0
 - Landesgewerbeamt Bayern**
Tillystrasse 2
90431 Nürnberg
Tel +49 (0) 9 11. 66 64 96
- **For all questions concerning health and safety and work, safety technology and accident prevention, please contact, in Bavaria:**
 - Bayerisches Landesamt für Gesundheit und Lebensmittelsicherheit**
Pfarrstrasse 3
80538 München
Tel +49 (0) 89. 21 84-0
Fax +49 (0) 89. 21 84-2 97
www.lgl.bayern.de

(continued)

Notification of a laser system

Return to
 NürnbergMesse GmbH
 Abteilung Veranstaltungstechnik
 Messezentrum
 90471 Nürnberg, Deutschland
 veranstaltungstechnik@nuernbergmesse.de
 www.nuernbergmesse.de

Event _____

Company _____

Street _____

Postcode, Town, Country _____

Person to contact _____

Tel _____

E-mail _____

Return deadline _____ **Hall/Stand** _____
No later than 6 weeks before use

Because the **operation of laser systems** can cause dangers for visitors and employees of NürnbergMesse, their operation is **subject to notification**. Please complete a separate notification for each laser system.

1. Type of laser system on exhibition stand:

- Show/stage or display laser Laser measuring system Labelling laser
 Medical laser Cutting laser Other laser

2. In normal operation for the intended use, the system is classified as follows under IEC/EN 60825:

- Class 1 Class 1M Class 1C Class 2
 Class 2M Class 3R Class 3B Class 4

3. During the erection phase and maintenance, the system is classified as follows under IEC/EN 60825:

- Class 1 Class 1M Class 1C Class 2
 Class 2M Class 3R Class 3B Class 4

4. If your laser device is classified in class 3R, 3B or 4 during normal operation and/or during the erection phase, you will need to have on the stand a trained laser protection officer according to IEC/EN 60825 or OStrV (national). Please enclose a copy of the certification of the laser protection officer with this notification.

Name of laser protection officer: _____
 Telephone/mobile number: _____

5. The exhibited laser device has been classified or certified by an independent test institute (e.g. TÜV, BG-Zert., VDE, BSI, UL, FDA). Please enclose a copy of the **laser system certification** with this notification.

- TÜV BG-Zert. VDE BSI
 FDA UL other: _____

6. The laser source used in the laser device has the following specifications:

Laser manufacturer: _____
 Laser type/designation: _____
 Maximum output of energy: _____ W or J
 Pulse length/frequency: _____
 Wavelength: _____ nm

7. The exhibited laser device has a protective device according to EN 954-1 or EN 60204-1 and is classified accordingly in the following safety category:

- Category 1 Category 2 Category 3 Category 4
 Category B unknown other: _____

(continued)

Notification of a laser system

(continued)

Laser operation in class 3R, 3B or 4:

The operation of a class 3R, 3B or 4 laser device on the exhibition stand is only allowed if it has been tested before the start of the trade fair by a **publicly appointed, certified expert** and declared safe. After the safety inspection, you will be provided with an acceptance report.

The first copy and a **risk assessment according to § OStrV** should be retained at the stand and presented to the supervisory authorities on request.

The second copy should be handed over to NürnbergMesse.

Start-up of your laser systems will not be allowed if the exhibitor cannot produce the safety certificate.

- The exhibited laser device is operated on the exhibition stand in one of the **laser classes 3R, 3B or 4**. However, any risk to trade fair visitors is excluded by structural and/or organisational measures. For this, the system is inspected by a public appointed, certified expert. A corresponding safety certificate is available on the exhibition stand for presentation to NürnbergMesse.

Tested on site on/at: _____ date/time

Expert (name): _____

Telephone/mobile number: _____

I confirm with my signature that the safety conditions listed and defined in the acceptance report are complied with at all times.

In addition, I declare that I agree with the following:

If modifications or additions to the laser device are made after the inspection/acceptance by the publicly appointed, certified expert, the operating permit will expire.

NürnbergMesse is then entitled to switch off the power supply to the stand and to confiscate and secure the laser device (to be returned on the last day of the trade fair when the trade fair is over).

Place/date

Signature

The above operation of a laser system is approved by NürnbergMesse subject to the following conditions:

Place/date

Company stamp and signature (NürnbergMesse; Events Engineering)

The Radiation Protection Act (German RÖV) stipulates that X-ray equipment must be approved by the responsible Trade Inspectorate. This applies to both operation and shutdown. The respective approvals must be submitted to **NürnbergMesse** (veranstaltungstechnik@nuernbergmesse.de) at least 2 weeks before the start of the event.

Only type-approved X-ray equipment may be used. The use of other equipment is strictly prohibited at events organized by NürnbergMesse. NürnbergMesse reserves the right to have such equipment removed.

In accordance with § 4 of the Radiation Protection Act, the following equipment must be submitted for notification to the GAA.

1. X-ray equipment to be placed on the market with declaration of conformity according to the Medical Product Act or the current Product Liability Act.
2. Type-approved X-ray equipment with type approval number, individual test with serial number, stamp and signature of manufacturer.
3. Highly or fully protected equipment
4. X-ray training equipment

The form for approval of the notification is to be submitted to the Gewerbeaufsichtsamt (GAA) in Nuremberg (Trade Inspectorate) by not later than 2 weeks before the X-ray equipment is to be taken into operation.

The original and copy of the approval certificate must remain with the equipment and a copy submitted to NürnbergMesse 2 weeks before the start of the event.

Proof of radiation protection skills

The certificate of qualification of the radiation protection officer (as per RÖV) must be submitted to NürnbergMesse by not later than 2 weeks before the start of the event.

Radiation protection skills must be updated every 5 years in accordance with the directive on "Radiation Protection Skills and Proficiency".

Expert's certificate and inspection report

The operator himself is to appoint one of the following bodies to carry out the inspection.

LGA Bautechnik GmbH
Tillystrasse 2
90431 Nürnberg
Tel +49 (0) 9 11. 6 55-54 92
Fax +49 (0) 9 11. 6 55-56 18

or

TÜV SÜD Industrie Service GmbH
Edisonstrasse 15
90431 Nürnberg
Tel +49 (0) 9 11. 65 57-3 71
Fax +49 (0) 9 11. 65 57-3 30

The inspection report and certificate will be sent to the operator or direct to GAA. A copy of the test report from the expert must be sent to NürnbergMesse (Exhibition Technology Department) at least 2 weeks before the start of the event.

The operation of the following devices must be approved by the competent GAA according to §3 of the Radiation Protection Act:

- X-ray equipment without type approval of CE designation
- X-ray equipment used in technical radiography for coarse structural analysis in materials testing
- X-ray equipment for radiation therapy
- X-ray equipment for teleradiology
- X-ray equipment outside an X-ray room
- X-ray equipment for X-ray series examinations

Documents required for approval under §3 RÖV

- Form for approval
- Explanatory plans, drawings
- Explanatory descriptions
- **If applicable**, proof of the involvement of a medical physics expert or personnel and technical equipment used

Under the Radiation Protection Act, notice of the operation of X-ray equipment must be submitted to or approved by the authority responsible for health and safety at work (Trade Inspectorate, Regierungsbezirk Mittelfranken):

Gewerbeaufsichtsamt Mittelfranken
Roonstrasse 20
90429 Nürnberg
Tel +49 (0) 9 11. 9 28-0
Fax +49 (0) 9 11. 9 28-29 99

NürnbergMesse may intervene in the case of violations of these rules and is then entitled to switch off the power supply to the stand or to confiscate and secure the laser devices/equipment (to be returned on the last day of the trade fair when the trade fair is over).

For further information, please contact:

- **NürnbergMesse GmbH**
Abteilung Veranstaltungstechnik
Messezentrum
90471 Nürnberg
veranstaltungstechnik@nuernbergmesse.de
www.nuernbergmesse.de

Introduction:

Bioethanol stoves and fireplaces are becoming increasingly popular among exhibitors. As these involve naked flames with a greater risk of fire for NürnbergMesse if they are not used as intended, compliance with the following basic rules is mandatory.

Use:

Bioethanol stoves and fireplaces are not suitable for heating. The fire is real, but the stoves or fireplaces produce hardly any heat and the flickering flames only create a visual effect. They can be used in any room and do not need a chimney. They use the combustible liquid "bioethanol".

Conditions imposed by NürnbergMesse:

- Use only tested products. (Caution! – see photo)
- The minimum separation from combustible materials, furniture etc. is 1 meter. The minimum distance from the hall gangways is 1.50 meters.
- Use only fuels approved by the stove manufacturer.
- The fuel may only be used in the combustion box or chamber provided for this purpose.
- Fuel may only be refilled when the combustion chamber has cooled down (otherwise there is a risk of jet flames!).
- Do not spill fuel. Completely remove any spilled fuel before lighting the stove.
- Smoking is strictly prohibited on exhibition stands where combustible liquids are used.
- NürnbergMesse recommends using a candle lighter to light the flame.
- Only decorations approved for this kind of stove may be used in the combustion chamber.
- The maximum quantity of fuel that may be stored on each stand is 1 liter in breakable containers or 5 liters in unbreakable containers.
- The containers for bioethanol must bear the marking "GHS" (Globally Harmonized System) for the relevant hazardous substance.
- A foam extinguisher of at least S9 DIN EN 3 must be available on the stand. (Fire class AB, 9 kg).
- The equipment is to be set up firmly and secured to prevent it falling over.

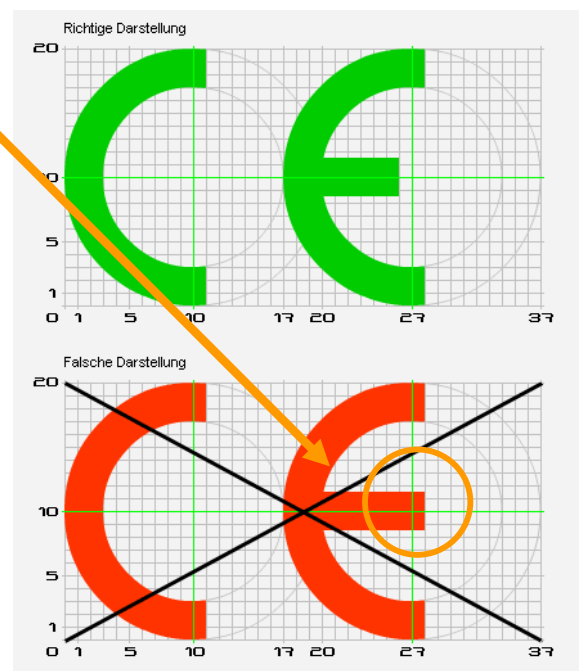

Important note:

The use of bioethanol stoves must always be registered in advance using **Form P2** from the Exhibitors Info Manual, and always requires the written approval of the NürnbergMesse Exhibition Technology Department.

veranstaltungstechnik@nuernbergmesse.de

Operation can only be approved if the bioethanol stoves are directly related to the exhibits on display.

NürnbergMesse GmbH
Exhibition Services
Messezentrum
90471 Nürnberg
Tel +49 (0) 9 11. 86 06-80 00
Fax +49 (0) 9 11. 86 06-80 01
messeservice@nuernbergmesse.de
www.embedded-world.de
www.nuernbergmesse.de
www.standconfigurator.com